



SiUS39 - 501

Service Manual

VRV-S[®]

**R410A Heat Pump 60Hz
RXYMQ-M Series**



VRV-S R410A Heat Pump 60Hz

1. Introduction	V
1.1 Safety Cautions.....	V
Part 1 General Information.....	1
1. Model Names of Indoor/Outdoor Units	2
2. External Appearance	3
2.1 Indoor Units.....	3
2.2 Outdoor Units.....	3
Part 2 Specifications	5
1. Specifications.....	6
1.1 Outdoor Units.....	6
1.2 Indoor Units.....	7
Part 3 List of Electrical and Functional Parts	17
1. List of Electrical and Functional Parts.....	18
1.1 Outdoor Units.....	18
1.2 Indoor Units.....	19
Part 4 Refrigerant Circuit.....	23
1. Refrigerant Circuit	24
1.1 RXYMQ36-48M.....	24
2. Functional Parts Layout	26
2.1 RXYMQ36-48M.....	26
Part 5 Function	27
1. Operation Mode	28
2. Basic Control.....	29
2.1 Normal Operation.....	29
2.2 Compressor PI Control	30
2.3 Electronic Expansion Valve PI Control	31
2.4 Cooling Operation Fan Control	32
3. Special Control.....	33
3.1 Startup Control.....	33
3.2 Oil Return Operation	34
3.3 Defrosting Operation.....	36
3.4 Pump-down Residual Operation	37
3.5 Restart Standby	38
3.6 Stopping Operation	39
3.7 Pressure Equalization Prior to Startup.....	40

4.	Protection Control	41
4.1	High Pressure Protection Control	41
4.2	Low Pressure Protection Control	42
4.3	Discharge Pipe Protection Control	43
4.4	Inverter Protection Control	44
5.	Other Control	45
5.1	Demand Operation.....	45
5.2	Heating Operation Prohibition.....	45
6.	Outline of Control (Indoor Unit)	46
6.1	Drain Pump Control	46
6.2	Louver Control for Preventing Ceiling Dirt	48
6.3	Thermostat Sensor in Remote Controller	49
6.4	Freeze Prevention.....	51
6.5	View of Operations of Swing Flaps	52

Part 6 Test Operation 53

1.	Test Operation	54
1.1	Procedure and Outline	54
1.2	Operation When Power is Turned On.....	57
2.	Outdoor Unit PC Board Layout	58
3.	Field Setting	59
3.1	Field Setting from Remote Controller.....	59
3.2	Field Setting from Outdoor Unit	70
3.3	Detail of Setting Mode.....	76

Part 7 Troubleshooting 87

1.	Troubleshooting by Remote Controller	90
1.1	The INSPECTION / TEST Button	90
1.2	Self-Diagnosis by Wired Remote Controller.....	91
1.3	Self-Diagnosis by Wireless Remote Controller	92
1.4	Operation of the Remote Controller's Inspection / Test Operation Button.....	94
1.5	Remote Controller Service Mode	95
2.	List of Malfunction Code	97
3.	Malfunction Code Indication by Outdoor Unit PCB	100
4.	Troubleshooting by Indication on the Remote Controller.....	102
4.1	"R0" Indoor Unit: Error of External Protection Device	102
4.2	"R1" Indoor Unit: PC Board Defect	103
4.3	"R3" Indoor Unit: Malfunction of Drain Level Control System (S1L).....	104
4.4	"R5" Indoor Unit: Fan Motor (M1F) Lock, Overload	106
4.5	"R7" Indoor Unit: Malfunction of Swing Flap Motor (MA).....	107
4.6	"R9" Indoor Unit: Malfunction of Moving Part of Electronic Expansion Valve (20E)	109
4.7	"RF" Indoor Unit: Drain Level above Limit	111
4.8	"RJ" Indoor Unit: Malfunction of Capacity Determination Device.....	112
4.9	"CY" Indoor Unit: Malfunction of Thermistor (R2T) for Heat Exchanger	113

4.10	“E5” Indoor Unit: Malfunction of Thermistor (R3T) for Gas Pipes	114
4.11	“E9” Indoor Unit: Malfunction of Thermistor (R1T) for Suction Air	115
4.12	“ER” Indoor Unit: Malfunction of Thermistor for Discharge Air	116
4.13	“EJ” Indoor Unit: Malfunction of Thermostat Sensor in Remote Controller	117
4.14	“E1” Outdoor Unit: PC Board Defect.....	118
4.15	“E3” Outdoor Unit: Actuation of High Pressure Switch.....	119
4.16	“E4” Outdoor Unit: Actuation of Low Pressure Switch	120
4.17	“E5” Outdoor Unit: Compressor Motor Lock.....	122
4.18	“E7” Outdoor Unit: Malfunction of Outdoor Unit Fan Motor	123
4.19	“E9” Outdoor Unit: Malfunction of Moving Part of Electronic Expansion Valve	125
4.20	“F3” Outdoor Unit: Abnormal Discharge Pipe Temperature	127
4.21	“H9” Outdoor Unit: Malfunction of Thermistor (R1T) for Outdoor Air	128
4.22	“J3” Outdoor Unit: Malfunction of Discharge Pipe Thermistor (R3T)....	129
4.23	“J5” Outdoor Unit: Malfunction of Thermistor (R2T) for Suction Pipe...	130
4.24	“J6” Outdoor Unit: Malfunction of Thermistor (R4T) for Outdoor Unit Heat Exchanger	131
4.25	“J9” Outdoor Unit: Malfunction of Subcooling Heat Exchanger Gas Pipe Thermistor (R5T).....	132
4.26	“JR” Outdoor Unit: Malfunction of High Pressure Sensor	133
4.27	“JC” Outdoor Unit: Malfunction of Low Pressure Sensor	135
4.28	“L4” Outdoor Unit: Malfunction of Inverter Radiating Fin Temperature Rise	136
4.29	“L5” Outdoor Unit: Inverter Compressor Abnormal.....	137
4.30	“L8” Outdoor Unit: Inverter Current Abnormal.....	138
4.31	“L9” Outdoor Unit: Inverter Start up Error	140
4.32	“LC” Outdoor Unit: Malfunction of Transmission between Inverter and Control PC Board.....	141
4.33	“P4” Outdoor Unit: Malfunction of Inverter Radiating Fin Temperature Rise Sensor.....	143
4.34	“PJ” Outdoor Unit: Faulty Combination of Inverter and Fan Driver	144
4.35	“U0” Outdoor Unit: Low Pressure Drop Due to Refrigerant Shortage or Electronic Expansion Valve Failure.....	145
4.36	“U2” Outdoor Unit: Power Supply Insufficient or Instantaneous Failure	146
4.37	“U3” Outdoor Unit: Check Operation not Executed.....	148
4.38	“U4” Malfunction of Transmission between Indoor Units and Outdoor Units.....	149
4.39	“U5” Indoor Unit: Malfunction of Transmission between Remote Controller and Indoor Unit.....	151
4.40	“U8” Indoor Unit: Malfunction of Transmission between Main and Sub Remote Controllers.....	152
4.41	“U9” Indoor Unit: Malfunction of Transmission between Indoor Units and Outdoor Units in the Same System	153
4.42	“UR” Improper Combination of Indoor Units and Outdoor Units, Indoor Units and Remote Controller	155
4.43	“UC” Address Duplication of Central Remote Controller.....	156

4.44	“UE” Malfunction of Transmission between Central Remote Controller and Indoor Unit.....	157
4.45	“UF” System not Set yet	159
4.46	“UH” Malfunction of System, Refrigerant System Address Undefined.....	160
5.	Troubleshooting by Indication on the Central Remote Controller	161
5.1	“UE” Malfunction of Transmission between Central Remote Controller and Indoor Unit.....	161
5.2	“M1” PC Board Defect.....	163
5.3	“M8” Malfunction of Transmission between Optional Controllers for Centralized Control	164
5.4	“M9” Improper Combination of Optional Controllers for Centralized Control	165
5.5	“M10” Address Duplication, Improper Setting.....	167
6.	Troubleshooting by Indication on the Unified ON/OFF Controller.....	168
6.1	Operation Lamp Blinks.....	168
6.2	Display “Under Centralized Control” Blinks (Repeats Single Blink).....	170
6.3	Display “Under Centralized Control” Blinks (Repeats Double Blink)....	173
7.	Troubleshooting (OP: Schedule Timer)	174
7.1	“UE” Malfunction of Transmission between Central Remote Controller and Indoor Unit.....	174
7.2	“M1” PC Board Defect.....	176
7.3	“M8” Malfunction of Transmission between Optional Controllers for Centralized Control	177
7.4	“M9” Improper Combination of Optional Controllers for Centralized Control	178
7.5	“M10” Address Duplication, Improper Setting.....	180
8.	Check.....	181

Part 8 Appendix 183

1.	Piping Diagrams.....	184
1.1	Outdoor Unit.....	184
1.2	Indoor Unit	185
2.	Wiring Diagrams for Reference.....	186
2.1	Outdoor Unit.....	186
2.2	Indoor Unit	187
3.	Thermistor Resistance / Temperature Characteristics.....	190
4.	Pressure Sensor	192

Part 9 Precautions for New Refrigerant (R410A) 193

1.	Precautions for New Refrigerant (R410A)	194
1.1	Outline.....	194
1.2	Service Tools	196





Index i

Drawings & Flow Chartsv







1. Introduction







1.1 Safety Cautions

Cautions and Warnings

- Be sure to read the following safety cautions before conducting repair work.
- The caution items are classified into “ **Warning**” and “ **Caution**”. The “ **Warning**” items are especially important since they can lead to death or serious injury if they are not followed closely. The “ **Caution**” items can also lead to serious accidents under some conditions if they are not followed. Therefore, be sure to observe all the safety caution items described below.
- About the pictograms
 - △ This symbol indicates an item for which caution must be exercised.
The pictogram shows the item to which attention must be paid.
 - This symbol indicates a prohibited action.
The prohibited item or action is shown inside or near the symbol.
 - This symbol indicates an action that must be taken, or an instruction.
The instruction is shown inside or near the symbol.
- After the repair work is complete, be sure to conduct a test operation to ensure that the equipment operates normally, and explain the cautions for operating the product to the customer



1.1.1 Caution in Repair



 Warning	
Be sure to disconnect the power cable plug from the plug socket before disassembling the equipment for a repair. Working on the equipment that is connected to a power supply can cause an electrical shock. If it is necessary to supply power to the equipment to conduct the repair or inspecting the circuits, do not touch any electrically charged sections of the equipment.	
If the refrigerant gas discharges during the repair work, do not touch the discharging refrigerant gas. The refrigerant gas can cause frostbite.	
When disconnecting the suction or discharge pipe of the compressor at the welded section, release the refrigerant gas completely at a well-ventilated place first. If there is a gas remaining inside the compressor, the refrigerant gas or refrigerating machine oil discharges when the pipe is disconnected, and it can cause injury.	
If the refrigerant gas leaks during the repair work, ventilate the area. The refrigerant gas can generate toxic gases when it contacts flames.	
The step-up capacitor supplies high-voltage electricity to the electrical components of the outdoor unit. Be sure to discharge the capacitor completely before conducting repair work. A charged capacitor can cause an electrical shock.	
Do not start or stop the air conditioner operation by plugging or unplugging the power cable plug. Plugging or unplugging the power cable plug to operate the equipment can cause an electrical shock or fire.	

 Caution	
Do not repair the electrical components with wet hands. Working on the equipment with wet hands can cause an electrical shock.	
Do not clean the air conditioner by splashing water. Washing the unit with water can cause an electrical shock.	
Be sure to provide the grounding when repairing the equipment in a humid or wet place, to avoid electrical shocks.	
Be sure to turn off the power switch and unplug the power cable when cleaning the equipment. The internal fan rotates at a high speed, and cause injury.	
Do not tilt the unit when removing it. The water inside the unit can spill and wet the furniture and floor.	
Be sure to check that the refrigerating cycle section has cooled down sufficiently before conducting repair work. Working on the unit when the refrigerating cycle section is hot can cause burns.	
Use the welder in a well-ventilated place. Using the welder in an enclosed room can cause oxygen deficiency.	



1.1.2 Cautions Regarding Products after Repair



 Warning	
Be sure to use parts listed in the service parts list of the applicable model and appropriate tools to conduct repair work. Never attempt to modify the equipment. The use of inappropriate parts or tools can cause an electrical shock, excessive heat generation or fire.	
When relocating the equipment, make sure that the new installation site has sufficient strength to withstand the weight of the equipment. If the installation site does not have sufficient strength and if the installation work is not conducted securely, the equipment can fall and cause injury.	
Be sure to install the product correctly by using the provided standard installation frame. Incorrect use of the installation frame and improper installation can cause the equipment to fall, resulting in injury.	For integral units only
Be sure to install the product securely in the installation frame mounted on a window frame. If the unit is not securely mounted, it can fall and cause injury.	For integral units only



 Warning	
Be sure to use an exclusive power circuit for the equipment, and follow the technical standards related to the electrical equipment, the internal wiring regulations and the instruction manual for installation when conducting electrical work. Insufficient power circuit capacity and improper electrical work can cause an electrical shock or fire.	
Be sure to use the specified cable to connect between the indoor and outdoor units. Make the connections securely and route the cable properly so that there is no force pulling the cable at the connection terminals. Improper connections can cause excessive heat generation or fire.	
When connecting the cable between the indoor and outdoor units, make sure that the terminal cover does not lift off or dismount because of the cable. If the cover is not mounted properly, the terminal connection section can cause an electrical shock, excessive heat generation or fire.	
Do not damage or modify the power cable. Damaged or modified power cable can cause an electrical shock or fire. Placing heavy items on the power cable, and heating or pulling the power cable can damage the cable.	
Do not mix air or gas other than the specified refrigerant in the refrigerant system. If air enters the refrigerating system, an excessively high pressure results, causing equipment damage and injury.	
If the refrigerant gas leaks, be sure to locate the leak and repair it before charging the refrigerant. After charging refrigerant, make sure that there is no refrigerant leak. If the leak cannot be located and the repair work must be stopped, be sure to perform pump-down and close the service valve, to prevent the refrigerant gas from leaking into the room. The refrigerant gas itself is harmless, but it can generate toxic gases when it contacts flames, such as fan and other heaters, stoves and ranges.	
When replacing the coin battery in the remote controller, be sure to disposed of the old battery to prevent children from swallowing it. If a child swallows the coin battery, see a doctor immediately.	

 Caution	
Installation of a leakage breaker is necessary in some cases depending on the conditions of the installation site, to prevent electrical shocks.	
Do not install the equipment in a place where there is a possibility of combustible gas leaks. If a combustible gas leaks and remains around the unit, it can cause a fire.	
Be sure to install the packing and seal on the installation frame properly. If the packing and seal are not installed properly, water can enter the room and wet the furniture and floor.	For integral units only

1.1.3 Inspection after Repair

 Warning	
Check to make sure that the power cable plug is not dirty or loose, then insert the plug into a power outlet all the way. If the plug has dust or loose connection, it can cause an electrical shock or fire.	





 Warning	
If the power cable and lead wires have scratches or deteriorated, be sure to replace them. Damaged cable and wires can cause an electrical shock, excessive heat generation or fire.	
Do not use a joined power cable or extension cable, or share the same power outlet with other electrical appliances, since it can cause an electrical shock, excessive heat generation or fire.	

 Caution	
Check to see if the parts and wires are mounted and connected properly, and if the connections at the soldered or crimped terminals are secure. Improper installation and connections can cause excessive heat generation, fire or an electrical shock.	
If the installation platform or frame has corroded, replace it. Corroded installation platform or frame can cause the unit to fall, resulting in injury.	
Check the grounding, and repair it if the equipment is not properly grounded. Improper grounding can cause an electrical shock.	
Be sure to measure the insulation resistance after the repair, and make sure that the resistance is 1 Mohm or higher. Faulty insulation can cause an electrical shock.	
Be sure to check the drainage of the indoor unit after the repair. Faulty drainage can cause the water to enter the room and wet the furniture and floor.	

1.1.4 Using Icons

Icons are used to attract the attention of the reader to specific information. The meaning of each icon is described in the table below:

1.1.5 Using Icons List

Icon	Type of Information	Description
 Note:	Note	A “note” provides information that is not indispensable, but may nevertheless be valuable to the reader, such as tips and tricks.
 Caution	Caution	A “caution” is used when there is danger that the reader, through incorrect manipulation, may damage equipment, lose data, get an unexpected result or has to restart (part of) a procedure.
 Warning	Warning	A “warning” is used when there is danger of personal injury.
	Reference	A “reference” guides the reader to other places in this binder or in this manual, where he/she will find additional information on a specific topic.

Part 1

General Information

1. Model Names of Indoor/Outdoor Units	2
2. External Appearance	3
2.1 Indoor Units.....	3
2.2 Outdoor Units.....	3

1. Model Names of Indoor/Outdoor Units

Indoor Units

Type		Model Name						Power Supply
Ceiling Mounted Cassette Type (Multi Flow)	FXFQ	12M	18M	24M	30M	36M	—	VJ
Ceiling Mounted Built-In Type	FXSQ	12M	18M	24M	30M	36M	48M	
Ceiling Mounted Duct Type	FXMQ	—	—	—	30M	36M	48M	
Ceiling Suspended Type	FXHQ	12M	—	24M	—	36M	—	
Wall Mounted Type	FXAQ	12M	18M	24M	—	—	—	
Floor Standing Type	FXLQ	12M	18M	24M	—	—	—	
Concealed Floor Standing Type	FXNQ	12M	18M	24M	—	—	—	

Outdoor Units (Inverter Series)





Series		Model Name		Power Supply
Inverter	Heat Pump	RXYMQ	36M	VJ
		RXYMQ	48M	

Power Supply Symbol

VJ: 1 ϕ , 208~230V, 60Hz

2. External Appearance

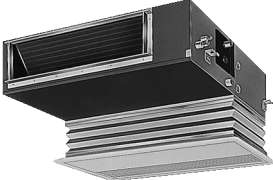
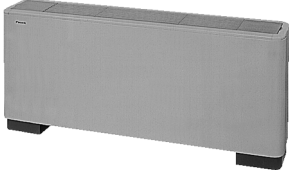
2.1 Indoor Units

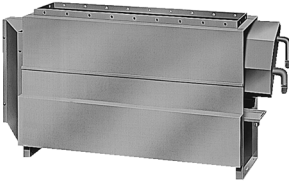
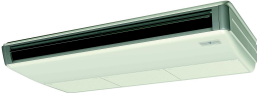
<p>Ceiling mounted cassette type (Multi flow)</p> <p>FXFQ12MVJU FXFQ18MVJU FXFQ24MVJU FXFQ30MVJU FXFQ36MVJU</p> 	<p>Wall mounted type</p> <p>FXAQ12MVJU FXAQ18MVJU FXAQ24MVJU</p> 
<p>Ceiling mounted built-in type</p> <p>FXSQ12MVJU FXSQ18MVJU FXSQ24MVJU FXSQ30MVJU FXSQ36MVJU FXSQ48MVJU</p> 	<p>Floor standing type</p> <p>FXLQ12MVJU FXLQ18MVJU FXLQ24MVJU</p> 
<p>Ceiling mounted duct type</p> <p>FXMQ30MVJU FXMQ36MVJU FXMQ48MVJU</p> 	<p>Concealed floor standing type</p> <p>FXNQ12MVJU FXNQ18MVJU FXNQ24MVJU</p> 
<p>Ceiling Suspended type</p> <p>FXHQ12MVJU FXHQ24MVJU FXHQ36MVJU</p> 	

2.2 Outdoor Units

RXYMQ36MVJU
RXYMQ48MVJU



Part 2

Specifications

1. Specifications.....	6
1.1 Outdoor Units.....	6
1.2 Indoor Units.....	7

1. Specifications

1.1 Outdoor Units

Model Name			RXYMQ36MVJU	RXYMQ48MVJU
★1 Cooling Capacity	Btu / h		36,000	48,000
★2 Heating Capacity	Btu / h		40,000	54,000
Casing Color			Ivory White (5Y7.5/1)	Ivory White (5Y7.5/1)
Dimensions: (H×W×D)		in	52-15/16 × 35-7/16 × 12-5/8	52-15/16 × 35-7/16 × 12-5/8
Heat Exchanger			Cross Fin Coil	Cross Fin Coil
Comp.	Type		Hermetically Sealed Scroll Type	Hermetically Sealed Scroll Type
	Piston Displacement	ft ³ /h	683.7	683.7
	Number of Revolutions	r.p.m	6480	6480
	Motor Output (2.2kW/60rps)	kW	2.3	3.1
	Starting Method		Direct on line	Direct on line
Fan	Type		Propeller Fan	Propeller Fan
	Motor Output	kW	0.070 × 2	0.070 × 2
	Air Flow Rate	cfm	3,740	3,740
	Drive		Direct Drive	Direct Drive
Connecting Pipes	Liquid Pipe	in	φ3/8 C1220T (Flare Connection)	φ3/8 C1220T (Flare Connection)
	Gas Pipe	in	φ5/8 C1220T (Flare Connection)	φ5/8 C1220T (Flare Connection)
Machine Weight (Mass)	Lbs		310	310
★3 Sound Level (Reference Value)	dBA		58	58
Safety Devices			High Pressure Switch, Fan Driver Overload Protector, Inverter Overload Protector, Fusible Plugs, Fuse	High Pressure Switch, Fan Driver Overload Protector, Inverter Overload Protector, Fusible Plugs, Fuse
Defrost Method			Reverse Cycle Defrosting	Reverse Cycle Defrosting
Capacity Control	%		29~100	29~100
Refrigerant	Refrigerant Name		R410A	R410A
	Charge	Lbs	12.8	12.8
	Control		Electronic Expansion Valve	Electronic Expansion Valve
Refrigerator Oil			Refer to the nameplate of compressor	Refer to the nameplate of compressor
Standard Accessories			Installation Manual, Operation Manual, Insulating tube, Clamps	Installation Manual, Operation Manual, Insulating tube, Clamps
Drawing No.			4D047379	

- Notes:**
- ★1 Indoor temp. : 80°FDB or 67°FWB / outdoor temp. : 95°FDB / Equivalent piping length : 25 ft, level difference: 0.
 - ★2 Indoor temp. : 70°FDB / outdoor temp. : 47°FDB or 43°FWB / Equivalent piping length : 25 ft, level difference: 0.
 - ★3 Anechoic chamber conversion value, measured under JISB8616 conditions. During actual operation, these values are normally somewhat higher as a result of ambient conditions.

1.2 Indoor Units

Ceiling Mounted Cassette Type (Multi-Flow)

Model			FXFQ12MVJU	FXFQ18MVJU	FXFQ24MVJU
★1 Cooling Capacity	Btu/h		12,000	18,000	24,000
★2 Heating Capacity	Btu/h		13,500	20,000	27,000
Casing / Color			Galvanized Steel Plate	Galvanized Steel Plate	Galvanized Steel Plate
Dimensions: (H×W×D)		in	9-1/8 × 33-1/8 × 33-1/8	9-1/8 × 33-1/8 × 33-1/8	9-1/8 × 33-1/8 × 33-1/8
Coil (Cross Fin Coil)	Rows×Stages×FPI		2 × 8 × 17	2 × 8 × 17	2×8×17
	Face Area	ft²	3.56	3.56	3.56
Fan	Model		QTS45B14M	QTS45B14M	QTS45B14M
	Type		Turbo Fan	Turbo Fan	Turbo Fan
	Motor Output	HP	0.06	0.06	0.06
	Air Flow Rate (H/L)	cfm	460/350	570/390	670/490
	Drive		Direct Drive	Direct Drive	Direct Drive
Temperature Control			Microprocessor Thermostat for Cooling and Heating	Microprocessor Thermostat for Cooling and Heating	Microprocessor Thermostat for Cooling and Heating
Sound Absorbing Thermal Insulation Material			Foamed Polystyrene / Foamed Polyethylene	Foamed Polystyrene / Foamed Polyethylene	Foamed Polystyrene / Foamed Polyethylene
Piping Connections	Liquid Pipes	in	φ1/4 (Flare Connection)	φ1/4 (Flare Connection)	φ3/8 (Flare Connection)
	Gas Pipes	in	φ1/2 (Flare Connection)	φ1/2 (Flare Connection)	φ5/8 (Flare Connection)
	Drain Pipe	in	VP25 (External Dia. 1-1/4 Internal Dia. 1)	VP25 (External Dia. 1-1/4 Internal Dia. 1)	VP25 (External Dia. 1-1/4 Internal Dia. 1)
Machine Weight (Mass)	Lbs		55	55	55
★4 Sound Level (H/L)	dBA		31/28	33/28	34/29
Safety Devices			Fuse, Thermal Protector for Fan Motor	Fuse, Thermal Protector for Fan Motor	Fuse, Thermal Protector for Fan Motor
Refrigerant Control			Electronic Expansion Valve	Electronic Expansion Valve	Electronic Expansion Valve
Connectable outdoor unit			RXYMQ36MVJU RXYMQ48MVJU	RXYMQ36MVJU RXYMQ48MVJU	RXYMQ36MVJU RXYMQ48MVJU
Decoration Panels (Option)	Model		BYC125K-W1	BYC125K-W1	BYC125K-W1
	Color		White (10Y9/0.5)	White (10Y9/0.5)	White (10Y9/0.5)
	Dimensions: (H×W×D)	in	1-5/8 × 37-3/8 × 37-3/8	1-5/8 × 37-3/8 × 37-3/8	1-5/8 × 37-3/8 × 37-3/8
	Air Filter		Resin Net (with Mold Resistant)	Resin Net (with Mold Resistant)	Resin Net (with Mold Resistant)
	Weight	Lbs		11	11
Standard Accessories			Operation manual, Installation manual, Paper pattern for installation, Drain hose, Clamp metal, Washers, Sealing pads, Clamps, Screws, Insulation for fitting.	Operation manual, Installation manual, Paper pattern for installation, Drain hose, Clamp metal, Washers, Sealing pads, Clamps, Screws, Insulation for fitting.	Operation manual, Installation manual, Paper pattern for installation, Drain hose, Clamp metal, Washers, Sealing pads, Clamps, Screws, Insulation for fitting.
Drawing No.			C:3D042686		

- Notes:**
- ★1 Nominal cooling capacities are based on the following conditions:
Return air temperature: 80°FDB, 67°FWB
Outdoor temperature: 95°FDB
Equivalent ref. piping length: 25ft (Horizontal)
 - ★2 Nominal heating capacities are based on the following conditions:
Return air temperature: 70°FDB
Outdoor temperature: 47°FDB, 43°FWB
Equivalent ref. piping length: 25ft (Horizontal)
 - 3 Capacities are net, including a deduction for cooling (an addition for heating) for indoor fan motor heat.
 - ★4 Anechoic chamber conversion value, measured under JISB8616 conditions. During actual operation, these values are normally somewhat higher as a result of installation conditions.

Ceiling Mounted Cassette Type (Multi-Flow)

Model		FXFQ30MVJU		FXFQ36MVJU	
★1 Cooling Capacity		Btu/h	30,000	36,000	
★2 Heating Capacity		Btu/h	34,000	40,000	
Casing / Color		Galvanized Steel Plate		Galvanized Steel Plate	
Dimensions: (H×W×D)		in	11-3/8 × 33-1/8 × 33-1/8	11-3/8 × 33-1/8 × 33-1/8	
Coil (Cross Fin Coil)	Rows×Stages×FPI	2 × 12 × 17		2×12×17	
	Face Area	ft²	5.35	5.35	
Fan	Model		QTS45A17M	QTS45A17M	
	Type		Turbo Fan	Turbo Fan	
	Motor Output	HP	0.12	0.12	
	Air Flow Rate (H/L)	cfm	990/710	990/740	
	Drive		Direct Drive	Direct Drive	
Temperature Control		Microprocessor Thermostat for Cooling and Heating		Microprocessor Thermostat for Cooling and Heating	
Sound Absorbing Thermal Insulation Material		Foamed Polystyrene / Foamed Polyethylene		Foamed Polystyrene / Foamed Polyethylene	
Piping Connections	Liquid Pipes	in	φ3/8 (Flare Connection)	φ3/8 (Flare Connection)	
	Gas Pipes	in	φ5/8 (Flare Connection)	φ5/8 (Flare Connection)	
	Drain Pipe	in	VP25 (External Dia. 1-1/4 Internal Dia. 1)	VP25 (External Dia. 1-1/4 Internal Dia. 1)	
Machine Weight (Mass)	Lbs	66	66		
★4 Sound Level (H/L)	dBA	38/32	40/33		
Safety Devices		Fuse, Thermal Protector for Fan Motor		Fuse, Thermal Protector for Fan Motor	
Refrigerant Control		Electronic Expansion Valve		Electronic Expansion Valve	
Connectable outdoor unit		RXYMQ36MVJU RXYMQ48MVJU		RXYMQ36MVJU RXYMQ48MVJU	
Decoration Panels (Option)	Model		BYC125K-W1	BYC125K-W1	
	Color		White (10Y9/0.5)	White (10Y9/0.5)	
	Dimensions: (H×W×D)	in	1-5/8 × 37-3/8 × 37-3/8	1-5/8 × 37-3/8 × 37-3/8	
	Air Filter		Resin Net (with Mold Resistant)	Resin Net (with Mold Resistant)	
	Weight	Lbs	11	11	
Standard Accessories		Operation manual, Installation manual, Paper pattern for installation, Drain hose, Clamp metal, Washers, Sealing pads, Clamps, Screws, Insulation for fitting.		Operation manual, Installation manual, Paper pattern for installation, Drain hose, Clamp metal, Washers, Sealing pads, Clamps, Screws, Insulation for fitting.	
Drawing No.		C:3D042686			

- Notes:**
- ★1 Nominal cooling capacities are based on the following conditions:
Return air temperature: 80°FDB, 67°FWB
Outdoor temperature: 95°FDB
Equivalent ref. piping length : 25ft (Horizontal)
 - ★2 Nominal heating capacities are based on the following conditions:
Return air temperature: 70°FDB.
Outdoor temperature: 47°FDB, 43°FWB
Equivalent ref. piping length: 25ft (Horizontal)
 - 3 Capacities are net, including a deduction for cooling (an addition for heating) for indoor fan motor heat.
 - ★4 Anechoic chamber conversion value, measured under JISB8616 conditions. During actual operation, these values are normally somewhat higher as a result of installation conditions.

Ceiling Mounted Built-In Type

Model			FXSQ12MVJU	FXSQ18MVJU	FXSQ24MVJU
★1 Cooling Capacity	Btu/h		12,000	18,000	24,000
★2 Heating Capacity	Btu/h		13,500	20,000	27,000
Casing / Color			Galvanized Steel Plate	Galvanized Steel Plate	Galvanized Steel Plate
Dimensions: (H×W×D)		in	11-7/8 × 21-5/8 × 31-1/2	11-7/8 × 27-1/2 × 31-1/2	11-7/8 × 39-3/8 × 31-1/2
Coil (Cross Fin Coil)	Rows×Stages×FPI		3 × 14 × 14	3 × 14 × 14	3 × 14 × 14
	Face Area	ft²	0.95	1.42	2.38
Fan	Model		D18H3A	D18H2A	2D18H2A
	Type		Sirocco Fan	Sirocco Fan	Sirocco Fan
	Motor Output	HP	0.07	0.11	0.17
	Air Flow Rate (H/L)	cfm	340/230	530/390	740/490
	External Static Pressure ★4	in. Aq	0.37-0.19-0.06	0.38-0.19-0.06	0.51-0.29-0.06
Drive		Direct Drive	Direct Drive	Direct Drive	
Temperature Control			Microprocessor Thermostat for Cooling and Heating	Microprocessor Thermostat for Cooling and Heating	Microprocessor Thermostat for Cooling and Heating
Sound Absorbing Thermal Insulation Material			Glass Fiber	Glass Fiber	Glass Fiber
Air Filter			Resin Net (with Mold Resistant)	Resin Net (with Mold Resistant)	Resin Net (with Mold Resistant)
Piping Connections	Liquid Pipes	in	φ1/4 (Flare Connection)	φ1/4 (Flare Connection)	φ3/8 (Flare Connection)
	Gas Pipes	in	φ1/2 (Flare Connection)	φ1/2 (Flare Connection)	φ5/8 (Flare Connection)
	Drain Pipe	in	VP25 (External Dia. 1-1/4 Internal Dia. 1)	VP25 (External Dia. 1-1/4 Internal Dia. 1)	VP25 (External Dia. 1-1/4 Internal Dia. 1)
Machine Weight (Mass)	Lbs		69	73	95
★5 Sound Level (H/L)	dBA		41/35	44/38	44/38
Safety Devices			Fuse, Thermal Protector for Fan Motor	Fuse, Thermal Protector for Fan Motor	Fuse, Thermal Protector for Fan Motor
Refrigerant Control			Electronic Expansion Valve	Electronic Expansion Valve	Electronic Expansion Valve
Connectable outdoor unit			RXYMQ36MVJU RXYMQ48MVJU	RXYMQ36MVJU RXYMQ48MVJU	RXYMQ36MVJU RXYMQ48MVJU
Decoration Panel (Option)	Model		BYBS32DJW1	BYBS45DJW1	BYBS71DJW1
	Panel Color		White (10Y9/0.5)	White (10Y9/0.5)	White (10Y9/0.5)
	Dimensions: (H×W×D)	in	2-1/8 × 25-5/8 × 19-5/8	2-1/8 × 31-1/2 × 19-5/8	2-1/8 × 43-1/4 × 19-5/8
Weight	Lbs		6.6	7.7	9.9
Standard Accessories			Operation Manual, Installation Manual, Paper Pattern for Installation, Drain Hose, Clamp Metal, Insulation for Fitting, Sealing Pads, Clamps, Screws, Washers.	Operation Manual, Installation Manual, Paper Pattern for Installation, Drain Hose, Clamp Metal, Insulation for Fitting, Sealing Pads, Clamps, Screws, Washers.	Operation Manual, Installation Manual, Paper Pattern for Installation, Drain Hose, Clamp Metal, Insulation for Fitting, Sealing Pads, Clamps, Screws, Washers.
Drawing No.			C:3D042684		

- Notes:**
- ★1 Nominal cooling capacities are based on the following conditions:
Return air temperature: 80°FDB, 67°FWB
Outdoor temperature: 95°FDB
Equivalent ref. piping length: 25ft (Horizontal)
 - ★2 Nominal heating capacities are based on the following conditions:
Return air temperature: 70°FDB.
Outdoor temperature: 47°FDB, 43°FWB
Equivalent ref. piping length: 25ft (Horizontal)
 - 3 Capacities are net, including a deduction for cooling (an addition for heating) for indoor fan motor heat.
 - ★4 External static pressure is changeable to change over the connectors inside electrical box, this pressure means "High static pressure – Standard – Low static pressure".
 - ★5 Anechoic chamber conversion value, measured under JISB8616 conditions. During actual operation, these values are normally somewhat higher as a result of installation conditions.

Ceiling Mounted Built-In Type

Model			FXSQ30MVJU	FXSQ36MVJU	FXSQ48MVJU
★1 Cooling Capacity	Btu/h		30,000	36,000	48,000
★2 Heating Capacity	Btu/h		34,000	40,000	54,000
Casing / Color			Galvanized Steel Plate	Galvanized Steel Plate	Galvanized Steel Plate
Dimensions: (H×W×D)		in	11-7/8 × 55-1/8 × 31-1/2	11-7/8 × 55-1/8 × 31-1/2	11-7/8 × 55-1/8 × 31-1/2
Coil (Cross Fin Coil)	Rows×Stages×FPI		3 × 14 × 14	3 × 14 × 14	3 × 14 × 14
	Face Area	ft²	3.64	3.64	3.64
Fan	Model		3D18H2A	3D18H2A	3D18H2A
	Type		Sirocco Fan	Sirocco Fan	Sirocco Fan
	Motor Output	HP	0.30	0.30	0.30
	Air Flow Rate (H/L)	cfm	950/720	990/740	1,300/950
	External Static Pressure ★4	in. Aq	0.57-0.39	0.57-0.35	0.34-0.10
Drive		Direct Drive	Direct Drive	Direct Drive	
Temperature Control			Microprocessor Thermostat for Cooling and Heating	Microprocessor Thermostat for Cooling and Heating	Microprocessor Thermostat for Cooling and Heating
Sound Absorbing Thermal Insulation Material			Glass Fiber	Glass Fiber	Glass Fiber
Air Filter			Resin Net (with Mold Resistant)	Resin Net (with Mold Resistant)	Resin Net (with Mold Resistant)
Piping Connections	Liquid Pipes	in	φ3/8 (Flare Connection)	φ3/8 (Flare Connection)	φ3/8 (Flare Connection)
	Gas Pipes	in	φ5/8 (Flare Connection)	φ5/8 (Flare Connection)	φ5/8 (Flare Connection)
	Drain Pipe	in	VP25 (External Dia. 1-1/4 Internal Dia. 1)	VP25 (External Dia. 1-1/4 Internal Dia. 1)	VP25 (External Dia. 1-1/4 Internal Dia. 1)
Machine Weight (Mass)	Lbs		119	119	122
★5 Sound Level (H/L)	dBA		45/39	45/39	48/43
Safety Devices			Fuse, Thermal Protector for Fan Motor	Fuse, Thermal Protector for Fan Motor	Fuse, Thermal Protector for Fan Motor
Refrigerant Control			Electronic Expansion Valve	Electronic Expansion Valve	Electronic Expansion Valve
Connectable outdoor unit			RXYMQ36MVJU RXYMQ48MVJU	RXYMQ36MVJU RXYMQ48MVJU	RXYMQ36MVJU RXYMQ48MVJU
Decoration Panel (Option)	Model		BYBS125DJW1	BYBS125DJW1	BYBS125DJW1
	Panel Color		White (10Y9/0.5)	White (10Y9/0.5)	White (10Y9/0.5)
	Dimensions: (H×W×D)	in	2-1/8 × 59 × 19-5/8	2-1/8 × 59 × 19-5/8	2-1/8 × 59 × 19-5/8
	Weight	Lbs	14	14	14
Standard Accessories			Operation Manual, Installation Manual, Paper Pattern for Installation, Drain Hose, Clamp Metal, Insulation for Fitting, Sealing Pads, Clamps, Screws, Washers.	Operation Manual, Installation Manual, Paper Pattern for Installation, Drain Hose, Clamp Metal, Insulation for Fitting, Sealing Pads, Clamps, Screws, Washers.	Operation Manual, Installation Manual, Paper Pattern for Installation, Drain Hose, Clamp Metal, Insulation for Fitting, Sealing Pads, Clamps, Screws, Washers.
Drawing No.			C:3D042684		

- Notes:**
- ★1 Nominal cooling capacities are based on the following conditions:
Return air temperature: 80°FDB, 67°FWB
Outdoor temperature: 95°FDB
Equivalent ref. piping length: 25ft (Horizontal)
 - ★2 Nominal heating capacities are based on the following conditions:
Return air temperature: 70°FDB.
Outdoor temperature: 47°FDB, 43°FWB
Equivalent ref. piping length: 25ft (Horizontal)
 - 3 Capacities are net, including a deduction for cooling (an addition for heating) for indoor fan motor heat.
 - ★4 External static pressure is changeable to change over the connectors inside electrical box, this pressure means "High static pressure – Standard".
 - ★5 Anechoic chamber conversion value, measured under JISB8616 conditions. During actual operation, these values are normally somewhat higher as a result of installation conditions.

Ceiling Mounted Duct Type

Model			FXMQ30MVJU	FXMQ36MVJU	FXMQ48MVJU
★1 Cooling Capacity	Btu/h		30,000	36,000	48,000
★2 Heating Capacity	Btu/h		34,000	40,000	54,000
Casing / Color			Galvanized Steel Plate	Galvanized Steel Plate	Galvanized Steel Plate
Dimensions: (H×W×D)		in	15-3/8 × 28-3/8 × 27-1/8	15-3/8 × 43-3/4 × 27-1/8	15-3/8 × 43-3/4 × 27-1/8
Coil (Cross Fin Coil)	Rows×Stages×FPI		3×16×13	3×16×13	3×16×13
	Face Area	ft²	1.95	3.43	3.43
Fan	Model		D11/2D3AA1VE	2D11/2D3AG1VE	2D11/2D3AF1VE
	Type		Sirocco Fan	Sirocco Fan	Sirocco Fan
	Motor Output	HP	0.21	0.36	0.58
	Air Flow Rate (H/L)	cfm	690/565	1,020/810	1,270/1,020
	External Static Pressure ★4	in. Aq	0.66-0.43	0.71-0.43	1.0-0.72
Drive		Direct Drive	Direct Drive	Direct Drive	
Temperature Control			Microprocessor Thermostat for Cooling and Heating	Microprocessor Thermostat for Cooling and Heating	Microprocessor Thermostat for Cooling and Heating
Sound Absorbing Thermal Insulation Material			Glass Fiber	Glass Fiber	Glass Fiber
Air Filter			★5	★5	★5
Piping Connections	Liquid Pipes	in	φ3/8 (Flare Connection)	φ3/8 (Flare Connection)	φ3/8 (Flare Connection)
	Gas Pipes	in	φ5/8 (Flare Connection)	φ5/8 (Flare Connection)	φ5/8 (Flare Connection)
	Drain Pipe	in	VP25 (External Dia. 1-1/4 Internal Dia. 1)	VP25 (External Dia. 1-1/4 Internal Dia. 1)	VP25 (External Dia. 1-1/4 Internal Dia. 1)
Machine Weight (Mass)	Lbs		99	139	144
★6 Sound Level (H/L)	dBA		45/41	45/41	48/45
Safety Devices			Fuse, Thermal Fuse for Fan Motor	Fuse, Thermal Fuse for Fan Motor	Fuse, Thermal Fuse for Fan Motor
Refrigerant Control			Electronic Expansion Valve	Electronic Expansion Valve	Electronic Expansion Valve
Connectable outdoor unit			RXYMQ36MVJU RXYMQ48MVJU	RXYMQ36MVJU RXYMQ48MVJU	RXYMQ36MVJU RXYMQ48MVJU
Standard Accessories			Operation Manual, Installation Manual, Drain Hose, Clamp Metal, Insulation for Fitting, Sealing Pads, Clamps, Screws.	Operation Manual, Installation Manual, Drain Hose, Clamp Metal, Insulation for Fitting, Sealing Pads, Clamps, Screws.	Operation Manual, Installation Manual, Drain Hose, Clamp Metal, Insulation for Fitting, Sealing Pads, Clamps, Screws.
Drawing No.			C:3D042685		

- Notes:**
- ★1 Nominal cooling capacities are based on the following conditions:
Return air temperature: 80°FDB, 67°FWB
Outdoor temperature: 95°FDB
Equivalent ref. piping length: 25ft (Horizontal)
 - ★2 Nominal heating capacities are based on the following conditions:
Return air temperature: 70°FDB
Outdoor temperature: 47°FDB, 43°FWB
Equivalent ref. piping length: 25ft (Horizontal)
 - 3 Capacities are net, including a deduction for cooling (an addition for heating) for indoor fan motor heat.
 - ★4 External static pressure is changeable to change over the connectors inside electrical box, this pressure means
"High static pressure – Standard".
 - ★5 Air filter is not standard accessory, but please mount it in the duct system of the suction side.
Select its colorimetric method (gravity method) 50% or more.
 - ★6 Anechoic chamber conversion value, measured under JISB8616 conditions. During actual operation, these values are normally somewhat higher as a result of installation conditions.

Ceiling Suspended Type

Model			FXHQ12MVJU	FXHQ24MVJU	FXHQ36MVJU
★1 Cooling Capacity	Btu/h		12,000	24,000	36,000
★2 Heating Capacity	Btu/h		13,500	27,000	40,000
Casing / Color			White(10Y9/0.5)	White(10Y9/0.5)	White(10Y9/0.5)
Dimensions: (H×W×D)		in	7-11/16×37-13/16×26-3/4	7-11/16×55-1/8×26-3/4	7-11/16×62-5/8×26-3/4
Coil (Cross Fin Coil)	Rows×Stages×FPI		2×12×15	3×12×15	2×12×15+2×10×15
	Face Area	ft²	1.96	3.15	3.66+2.95
Fan	Model		3D12K1AA1	3D12K2AA1	—
	Type		Sirocco Fan	Sirocco Fan	Sirocco Fan
	Motor Output	W	62	130	130
	Air Flow Rate (H/L)	cfm	410/340	710/600	830/670
Drive			Direct Drive	Direct Drive	Direct Drive
Temperature Control			Microprocessor Thermostat for Cooling and Heating	Microprocessor Thermostat for Cooling and Heating	Microprocessor Thermostat for Cooling and Heating
Sound Absorbing Thermal Insulation Material			Glass Wool	Glass Wool	Glass Wool
Air Filter			Resin Net (with Mold Resistant)		
Piping Connections	Liquid Pipes	in	φ1/4 (Flare Connection)	φ3/8 (Flare Connection)	φ3/8 (Flare Connection)
	Gas Pipes	in	φ1/2 (Flare Connection)	φ5/8 (Flare Connection)	φ5/8 (Flare Connection)
	Drain Pipes	in	VP20 (External Dia. 1 Internal Dia. 3/4)	VP20 (External Dia. 1 Internal Dia. 3/4)	VP20 (External Dia. 1 Internal Dia. 3/4)
Machine Weight (Mass)	Lbs		55	80	90
★4 Sound Level (H/L)	dBA		42	44	46
Safety Devices			Fuse, Thermal Protector for Fan Motor	Fuse, Thermal Protector for Fan Motor	Fuse, Thermal Protector for Fan Motor
Refrigerant Control			Electronic Expansion Valve	Electronic Expansion Valve	Electronic Expansion Valve
Connectable Outdoor Unit			RXYMQ36MVJU RXYMQ48MVJU	RXYMQ36MVJU RXYMQ48MVJU	RXYMQ36MVJU RXYMQ48MVJU
Standard Accessories			Operation Manual, Installation Manual, Drain Hose, Paper Pattern for Installation, Clamp Metal, Insulation for Fitting, Clamps, Washers.	Operation Manual, Installation Manual, Drain Hose, Paper Pattern for Installation, Clamp Metal, Insulation for Fitting, Clamps, Washers.	Operation Manual, Installation Manual, Drain Hose, Paper Pattern for Installation, Clamp Metal, Insulation for Fitting, Clamps, Washers.
Drawing No.			C:4D049326		

Notes:

- ★1 Nominal cooling capacities are based on the following conditions:
Return air temperature: 80°FDB, 67°FWB
Outdoor temperature: 95°FDB
Equivalent ref. piping length: 25ft (Horizontal)
- ★2 Nominal heating capacities are based on the following conditions:
Return air temperature: 70°FDB.
Outdoor temperature: 47°FDB, 43°FWB
Equivalent ref. piping length: 25ft (Horizontal)
- 3 Capacities are net, including a deduction for cooling (an addition for heating) for indoor fan motor heat.
- 4 Anechoic chamber conversion value, measured under JISB8616 conditions. During actual operation, these values are normally somewhat higher as a result of installation conditions.

Wall Mounted Type

Model			FXAQ12MVJU	FXAQ18MVJU	FXAQ24MVJU
★1 Cooling Capacity	Btu/h		12,000	18,000	24,000
★2 Heating Capacity	Btu/h		13,500	20,000	27,000
Casing Color			White (3.0Y8.5/0.5)	White (3.0Y8.5/0.5)	White (3.0Y8.5/0.5)
Dimensions: (H×W×D)		in	11-3/8×31-1/4×9	11-3/8×41-3/8×9	11-3/8×41-3/8×9
Coil (Cross Fin Coil)	Rows×Stages×FPI		2×14×17	2×14×17	2×14×17
	Face Area	ft²	1.73	2.29	2.29
Fan	Model		QCL9661M	QCL9686	QCL9686
	Type		Cross Flow Fan	Cross Flow Fan	Cross Flow Fan
	Motor Output	HP	0.054	0.058	0.058
	Air Flow Rate (H/L)	cfm	300/180	500/400	635/470
	Drive		Direct Drive	Direct Drive	Direct Drive
Temperature Control			Microprocessor Thermostat for Cooling and Heating	Microprocessor Thermostat for Cooling and Heating	Microprocessor Thermostat for Cooling and Heating
Sound Absorbing Thermal Insulation Material			Foamed Polystyrene / Foamed Polyethylene	Foamed Polystyrene / Foamed Polyethylene	Foamed Polystyrene / Foamed Polyethylene
Air Filter			Resin Net (Washable)	Resin Net (Washable)	Resin Net (Washable)
Piping Connections	Liquid Pipes	in	φ1/4 (Flare Connection)	φ1/4 (Flare Connection)	φ3/8 (Flare Connection)
	Gas Pipes	in	φ1/2 (Flare Connection)	φ1/2 (Flare Connection)	φ5/8 (Flare Connection)
	Drain Pipe	in	VP13 (External Dia. 11/16 Internal Dia. 1/2)	VP13 (External Dia. 11/16 Internal Dia. 1/2)	VP13 (External Dia. 11/16 Internal Dia. 1/2)
Machine Weight (Mass)	Lbs		25	31	31
★4 Sound Level (H)	dBA		38	43	47
Safety Devices			Fuse	Fuse	Fuse
Refrigerant Control			Electronic Expansion Valve	Electronic Expansion Valve	Electronic Expansion Valve
Connectable Outdoor Unit			RXYMQ36MVJU RXYMQ48MVJU	RXYMQ36MVJU RXYMQ48MVJU	RXYMQ36MVJU RXYMQ48MVJU
Standard Accessories			Operation Manual, Installation Manual, Installation Panel, Paper Pattern for Installation, Insulation Tube, Clamps, Screws.	Operation Manual, Installation Manual, Installation Panel, Paper Pattern for Installation, Insulation Tube, Clamps, Screws.	Operation Manual, Installation Manual, Installation Panel, Paper Pattern for Installation, Insulation Tube, Clamps, Screws.
Drawing No.			3D046038		

- Notes:**
- ★1 Nominal cooling capacities are based on the following conditions:
 Return air temperature: 80°FDB, 67°FWB
 Outdoor temperature: 95°FDB
 Equivalent ref. piping length: 25ft (Horizontal)
 - ★2 Nominal heating capacities are based on the following conditions:
 Return air temperature: 70°FDB.
 Outdoor temperature: 47°FDB, 43°FWB
 Equivalent ref. piping length: 25ft (Horizontal)
 - 3 Capacities are net, including a deduction for cooling (an addition for heating) for indoor fan motor heat.
 - 4 Anechoic chamber conversion value, measured under JISB8616 conditions. During actual operation, these values are normally somewhat higher as a result of installation conditions.

Floor Standing Type

Model			FXLQ12MVJU	FXLQ18MVJU	FXLQ24MVJU
★1 Cooling Capacity		Btu/h	12,000	18,000	24,000
★2 Heating Capacity		Btu/h	13,500	20,000	27,000
Casing Color			Ivory White (5Y7.5/1)	Ivory White (5Y7.5/1)	Ivory White (5Y7.5/1)
Dimensions: (H×W×D)		in	23-5/8×44-7/8×8-3/4	23-5/8×55-7/8×8-3/4	23-5/8×55-7/8×8-3/4
Coil (Cross Fin Coil)	Rows×Stages×FPI		3×14×17	3×14×17	3×14×17
	Face Area	ft²	2.15	3.04	3.04
Fan	Model		2D14B13	2D14B20	2D14B20
	Type		Sirocco Fan	Sirocco Fan	Sirocco Fan
	Motor Output	HP	0.034	0.047	0.047
	Air Flow Rate (H/L)	cfm	280/210	490/380	560/420
Drive			Direct Drive	Direct Drive	Direct Drive
Temperature Control			Microprocessor Thermostat for Cooling and Heating	Microprocessor Thermostat for Cooling and Heating	Microprocessor Thermostat for Cooling and Heating
Sound Absorbing Thermal Insulation Material			Glass Fiber/ Urethane Foam	Glass Fiber/ Urethane Foam	Glass Fiber/ Urethane Foam
Air Filter			Resin Net (with Mold Resistant)	Resin Net (with Mold Resistant)	Resin Net (with Mold Resistant)
Piping Connections	Liquid Pipes	in	φ1/4 (Flare Connection)	φ1/4 (Flare Connection)	φ3/8 (Flare Connection)
	Gas Pipes	in	φ1/2 (Flare Connection)	φ1/2 (Flare Connection)	φ5/8 (Flare Connection)
	Drain Pipe	in	φ27/32 O.D (Vinyl Chloride)	φ27/32 O.D (Vinyl Chloride)	φ27/32 O.D (Vinyl Chloride)
Machine Weight (Mass)		Lbs	66	80	80
★4 Sound Level (H)		dBA	36	40	41
Safety Devices			Fuse, Thermal Protector for Fan Motor	Fuse, Thermal Protector for Fan Motor	Fuse, Thermal Protector for Fan Motor
Refrigerant Control			Electronic Expansion Valve	Electronic Expansion Valve	Electronic Expansion Valve
Connectable Outdoor Unit			RXYMQ36MVJU RXYMQ48MVJU	RXYMQ36MVJU RXYMQ48MVJU	RXYMQ36MVJU RXYMQ48MVJU
Standard Accessories			Operation Manual, Installation Manual, Insulation for Fitting, Drain Hose, Clamps, Screws, Washers, Level Adjustment Screw.	Operation Manual, Installation Manual, Insulation for Fitting, Drain Hose, Clamps, Screws, Washers, Level Adjustment Screw.	Operation Manual, Installation Manual, Insulation for Fitting, Drain Hose, Clamps, Screws, Washers, Level Adjustment Screw.
Drawing No.			3D045640		

- Notes:**
- ★1 Nominal cooling capacities are based on the following conditions:
Return air temperature: 80°FDB, 67°FWB
Outdoor temperature: 95°FDB
Equivalent ref. piping length: 25ft (Horizontal)
 - ★2 Nominal heating capacities are based on the following conditions:
Return air temperature: 70°FDB.
Outdoor temperature: 47°FDB, 43°FWB
Equivalent ref. piping length: 25ft (Horizontal)
 - 3 Capacities are net, including a deduction for cooling (an addition for heating) for indoor fan motor heat.
 - ★4 Anechoic chamber conversion value, measured under JISB8616 conditions. During actual operation, these values are normally somewhat higher as a result of installation conditions.

Concealed Floor Standing Type

Model			FXNQ12MVJU	FXNQ18MVJU	FXNQ24MVJU
★1 Cooling Capacity	Btu/h		12,000	18,000	24,000
★2 Heating Capacity	Btu/h		13,500	20,000	27,000
Casing Color			Galvanized Steel Plate	Galvanized Steel Plate	Galvanized Steel Plate
Dimensions: (H×W×D)		in	24×42–1/8×8–5/8	24×53–1/8×8–5/8	24×53–1/8×8–5/8
Coil (Cross Fin Coil)	Rows×Stages×FPI		3×14×17	3×14×17	3×14×17
	Face Area	ft ²	2.15	3.04	3.04
Fan	Model		2D14B13	2D14B20	2D14B20
	Type		Sirocco Fan	Sirocco Fan	Sirocco Fan
	Motor Output	HP	0.034	0.047	0.047
	Air Flow Rate (H/L)	cfm	280/210	490/380	560/420
Drive		Direct Drive	Direct Drive	Direct Drive	
Temperature Control			Microprocessor Thermostat for Cooling and Heating	Microprocessor Thermostat for Cooling and Heating	Microprocessor Thermostat for Cooling and Heating
Sound Absorbing Thermal Insulation Material			Glass Fiber/ Urethane Foam	Glass Fiber/ Urethane Foam	Glass Fiber/ Urethane Foam
Air Filter			Resin Net (with Mold Resistant)	Resin Net (with Mold Resistant)	Resin Net (with Mold Resistant)
Piping Connections	Liquid Pipes	in	φ1/4 (Flare Connection)	φ1/4 (Flare Connection)	φ3/8 (Flare Connection)
	Gas Pipes	in	φ1/2 (Flare Connection)	φ1/2 (Flare Connection)	φ5/8 (Flare Connection)
	Drain Pipe	in	φ27/32 O.D (Vinyl Chloride)	φ27/32 O.D (Vinyl Chloride)	φ27/32 O.D (Vinyl Chloride)
Machine Weight (Mass)	Lbs		66	80	80
★4 Sound Level (H)	dBA		36	40	41
Safety Devices			Fuse, Thermal Protector for Fan Motor	Fuse, Thermal Protector for Fan Motor	Fuse, Thermal Protector for Fan Motor
Refrigerant Control			Electronic Expansion Valve	Electronic Expansion Valve	Electronic Expansion Valve
Connectable Outdoor Unit			RXYMQ36MVJU RXYMQ48MVJU	RXYMQ36MVJU RXYMQ48MVJU	RXYMQ36MVJU RXYMQ48MVJU
Standard Accessories			Operation Manual, Installation Manual, Insulation for Fitting, Drain Hose, Clamps, Screws, Washers, Level Adjustment Screw.	Operation Manual, Installation Manual, Insulation for Fitting, Drain Hose, Clamps, Screws, Washers, Level Adjustment Screw.	Operation Manual, Installation Manual, Insulation for Fitting, Drain Hose, Clamps, Screws, Washers, Level Adjustment Screw.
Drawing No.			3D045648		

- Notes:**
- ★1 Nominal cooling capacities are based on the following conditions:
Return air temperature: 80°FDB, 67°FWB
Outdoor temperature: 95°FDB
Equivalent ref. piping length: 25ft (Horizontal)
 - ★2 Nominal heating capacities are based on the following conditions:
Return air temperature: 70°FDB.
Outdoor temperature: 47°FDB, 43°FWB
Equivalent ref. piping length: 25ft (Horizontal)
 - 3 Capacities are net, including a deduction for cooling (an addition for heating) for indoor fan motor heat.
 - ★4 Anechoic chamber conversion value, measured under JISB8616 conditions. During actual operation, these values are normally somewhat higher as a result of installation conditions.

Part 3

List of Electrical and Functional Parts

1. List of Electrical and Functional Parts.....	18
1.1 Outdoor Units.....	18
1.2 Indoor Units.....	19

1. List of Electrical and Functional Parts

1.1 Outdoor Units

Item	Name		Symbol	Model		Remark (PCB terminal)
				36	48	
Compressor	Inverter	Type Output	M1C	JT100FCVDK@4 3.2kW		—
	Crankcase heater (INV)		E1HC	33W		A1P X6A
Fan motor	Motor		M1F·M2F	0.07kW		—
	Over-current relay		—	3.2A		—
Functional parts	Electronic expansion valve (Main)	Cooling	Y1E	1400pls		A1P X26A
		Heating		PI control		
	Electronic expansion valve (Subcool)	Cooling	Y2E	PI control		A1P X28A
		Heating		0pls		
	Solenoid valve (Hot gas)		Y1S	TEV1620DQ2		A1P X2A
	Solenoid valve (Receiver gas charge)		Y2S	TEV1620DQ2		A1P X3A
4 way valve		Y3S	VT40100		A1P X5A	
Pressure-related parts	Pressure switch (INV)		S1PH	ACB-4UB10 ON: 580+0/-22 psi OFF: 435±22 psi		A2P X60A
	Fusible plug		—	FPGH-3D 158~167°F		—
	Pressure sensor (HP)		S1NPH	PS8051A 0~602 psi		A1P X46A
	Pressure sensor (LP)		S1NPL	PS8051A -7~247 psi		A1P X45A
Thermistor	Main PCB	For outdoor air	R1T	3.5~360kΩ		A1P X44A
		For suction pipe	R2T	3.5~360kΩ		A1P X37A 1-2Pin
		For discharge pipe	R3T	3.5~400kΩ		A1P X34A 1-2Pin
		For heat exchanger	R4T	3.5~360kΩ		A1P X37A 3-4Pin
		For subcooling heat exchanger	R5T	3.5~360kΩ		A1P X37A 5-6Pin

1.2 Indoor Units

Parts Name		Symbol	Model					Remark
			FXFQ 12MVJU	FXFQ 18MVJU	FXFQ 24MVJU	FXFQ 30MVJU	FXFQ 36MVJU	
Remote Controller	Wired Remote Controller		BRC1C71					Option
	Wireless Remote Controller		BRC7C812					
Motors	Fan Motor	M1F	1φ45W 6P		1φ90W 6P			
			Thermal Protector 266°F : OFF			176°F : ON		
	Capacitor, fan motor	C1	3.5μF 450VAC			5.0μF 450VAC		
	Drain Pump	M1P	PLD-12230DM Thermal Fuse 293°F					
	Swing Motor	M1S	MP35HCA [3P007482-1]					
Thermistors	Thermistor (Suction Air)	R1T	ST8601A-1 φ4 L250 20kΩ (77°F)					
	Thermistor (for Heat Exchanger High Temp.)	R3T	ST8605-3 φ8 L630 20kΩ (77°F)					
	Thermistor (Heat Exchanger)	R2T	ST8602A-3 φ6 L630 20kΩ (77°F)					
Others	Float Switch	S1L	FS-0211					
	Fuse	F1U	250V 5A φ5.2					
	Transformer	T1R	TR25H25R0					

Parts Name		Symbol	Model						Remark
			FXSQ 12MVJU	FXSQ 18MVJU	FXSQ 24MVJU	FXSQ 30MVJU	FXSQ 36MVJU	FXSQ 48MVJU	
Remote Controller	Wired Remote Controller		BRC1C71						Option
	Wireless Remote Controller		BRC4C82						
Motors	Fan Motor	M1F	1φ50W 4P	1φ85W 4P	1φ125W 4P	1φ225W 4P			
			Thermal Fuse 305.6°F			Thermal protector 275°F : OFF 188.6°F : ON			
	Drain Pump	M1P	PLD-12230DM Thermal Fuse 336.2°F						
Thermistors	Thermistor (Suction Air)	R1T	ST8601-13 φ4 L630 20kΩ (77°F)						
	Thermistor (for Heat Exchanger High Temp.)	R3T	ST8605-7 φ8 L1600 20kΩ (77°F)						
	Thermistor (Heat Exchanger)	R2T	ST8602A-7 φ6 L1600 20kΩ (77°F)						
Others	Float Switch	S1L	FS-0211						
	Fuse	F1U	250V 5A φ5.2						
	Transformer	T1R	TR25H25R0						

Parts Name		Symbol	Model			Remark
			FXMQ 30MVJU	FXMQ 36MVJU	FXMQ 48MVJU	
Remote Controller	Wired Remote Controller		BRC1C71			Option
	Wireless Remote Controller		BRC4C82			
Motors	Fan Motor	M1F	1 ϕ 160W	1 ϕ 270W	1 ϕ 430W	
	Capacitor for Fan Motor	C1R	6 μ F 450V	9 μ F 450V	8 μ F 450V	
Thermistors	Thermistor (Suction Air)	R1T	ST8601A-5 ϕ 4 L1000 20k Ω (77°F)			
	Thermistor (for Heat Exchanger High Temp.)	R3T	ST8605A-4 ϕ 8 L800 20k Ω (77°F)			
	Thermistor (Heat Exchanger)	R2T	ST8602A-4 ϕ 6 L800 20k Ω (77°F)			
Others	Float switch	S1L	FS-0211			
	Fuse	F1U	250V 5A ϕ 5.2	250V 10A ϕ 5.2		
	Transformer	T1R	TR25H25R0			

Parts Name		Symbol	Model			Remark
			FXHQ 12MVJU	FXHQ 24MVJU	FXHQ 36MVJU	
Remote Controller	Wired Remote Controller		BRC1C71			Option
	Wireless Controller		BRC7E83			
Motors	Fan Motor	M1F	1 ϕ 63W	1 ϕ 130W		
	Capacitor for Fan Motor	C1R	3.0 μ F-450V	9.0 μ F-450V		
	Swing Motor	M1S	MT8-L[3P058751-1] AC200~240V			
Thermistors	Thermistor (Suction Air)	R1T	ST8601A-1 ϕ 4 L250 20k Ω (77°F)			
	Thermistor (for Heat Exchanger High Temp.)	R3T	ST8605-6 ϕ 8 L = 1250 20k Ω (77°F)	ST8605-6 ϕ 8 L = 1250 20k Ω (77°F)		
	Thermistor (Heat Exchanger)	R2T	ST8602A-6 ϕ 6 L = 1250 20k Ω (77°F)	ST8602A-6 ϕ 6 L = 1250 20k Ω (77°F)		
Others	Fuse	F1U	250V 5A			
	Transformer	T1R	TR25H25R0			

Parts Name		Symbol	Model			Remark
			FXAQ 12MVJU	FXAQ 18MVJU	FXAQ 24MVJU	
Remote Controller	Wired Remote Controller		BRC1C71			Option
	Wireless Remote Controller		BRC7E818			
Motors	Fan Motor	M1F	1 ϕ 40W	1 ϕ 43W		
	Swing Motor	M1S	MP24[3SB40333-1] AC200~240V	MSFBC20C21 [3SB40550-1] AC200~240V		
Thermistors	Thermistor (Suction Air)	R1T	ST8601-2 ϕ 4 L400 20k Ω (77°F)			
	Thermistor (for Heat Exchanger High Temp.)	R3T	ST8605-2 ϕ 8 L400 20k Ω (77°F)			
	Thermistor (for Heat Exchanger)	R2T	ST8602-2 ϕ 6 L400 20k Ω (77°F)			
Others	Float Switch	S1L	OPTION			
	Fuse	F1U	250V 3.15A			

Parts Name		Symbol	Model			Remark
			FXLQ 12MVJU	FXLQ 18MVJU	FXLQ 24MVJU	
Remote Controller	Wired Remote Controller		BRC1C71			Option
	Wireless Remote Controller		—			
Motors	Fan Motor	M1F	1 ϕ 25W	1 ϕ 35W		
	Capacitor for Fan Motor	C1R	0.5 μ F-450V	1.5 μ F-450V	2.0 μ F-450V	
Thermistors	Thermistor (Suction Air)	R1T	ST8601-6 ϕ 4 L1250 20k Ω (77°F)			
	Thermistor (for Heat Exchanger High Temp.)	R3T	ST8605-9 ϕ 8 L2500 20k Ω (77°F)			
	Thermistor (for Heat Exchanger)	R2T	ST8602A-9 ϕ 6 L2500 20k Ω (77°F)			
Others	Fuse	F1U	AC250V 5A			
	Transformer	T1R	TR25H25R0			

Parts Name		Symbol	Model			Remark
			FXNQ 12MVJU	FXNQ 18MVJU	FXNQ 24MVJU	
Remote Controller	Wired Remote Controller		BRC1C71			Option
	Wireless Remote Controller		—			
Motors	Fan Motor	M1F	1 ϕ 25W	1 ϕ 35W		
	Capacitor for Fan Motor	C1R	0.5 μ F-450V	1.5 μ F-450V	2.0 μ F-450V	
Thermistors	Thermistor (Suction Air)	R1T	ST8601-6 ϕ 4 L1250 20k Ω (77°F)			
	Thermistor (for Heat Exchanger High Temp.)	R3T	ST8605-9 ϕ 8 L2500 20k Ω (77°F)			
	Thermistor (for Heat Exchanger)	R2T	ST8602A-9 ϕ 6 L2500 20k Ω (77°F)			
Others	Fuse	F1U	AC250V 5A			
	Transformer	T1R	TR25H25R0			

Part 4

Refrigerant Circuit

1. Refrigerant Circuit	24
1.1 RXYMQ36-48M	24
2. Functional Parts Layout	26
2.1 RXYMQ36-48M	26

1. Refrigerant Circuit

1.1 RXYMQ36-48M

No. in refrigerant system diagram	Symbol	Name	Major Function
A	M1C	Inverter compressor (INV)	Inverter compressor is operated on frequencies between 52 Hz and 177 Hz by using the inverter. 17 steps
D	M1F M2F	Inverter fan	Since the system is of air heat exchanging type, the fan is operated at 8-step rotation speed by using the inverter.
E	Y1E	Electronic expansion valve (Main: EV1)	While in heating operation, PI control is applied to keep the outlet superheated degree of air heat exchanger constant.
F	Y2E	Electronic expansion valve (Subcool: EV2)	PI control is applied to keep the outlet superheated degree of subcooling heat exchanger constant.
G	Y1S	Solenoid valve (Hot gas: SVP)	Used to prevent the low pressure from transient falling.
J	Y2S	Solenoid valve (Receiver gas discharging: SVG)	Used to collect refrigerant to receiver.
M	Y3S	Four way valve	Used to switch the operation mode between cooling and heating.
N	S1NPH	High pressure sensor	Used to detect high pressure.
O	S1NPL	Low pressure sensor	Used to detect low pressure.
P	S1PH	HP pressure switch (For INV compressor)	In order to prevent the increase of high pressure when a malfunction occurs, this switch is activated at high pressure of 580 psi or more to stop the compressor operation.
S	—	Fusible plug	In order to prevent the increase of pressure when abnormal heating is caused by fire or others, the fusible part of the plug is molten at a temperature of 158 to 167°F to release the pressure into the atmosphere.
T	—	Pressure regulating valve 1 (Receiver to discharge pipe)	This valve opens at a pressure of 290 to 390 psi for prevention of pressure increase, thus resulting in no damage of functional parts due to the increase of pressure in transportation or storage.
1	R1T	Thermistor (Outdoor air: Ta)	Used to detect outdoor temperature, correct discharge pipe temperature, and others.
2	R2T	Thermistor (Suction pipe: Ts)	used to detect suction pipe temperature, keep the suction superheated degree constant in heating operation, and others.
3	R3T	Thermistor (INV discharge pipe: Tdi)	used to detect discharge pipe temperature, make the temperature protection control of compressor, and others.
4	R4T	Thermistor (Heat exchanger deicer: Tb)	Used to detect liquid pipe temperature of air heat exchanger, determine defrosting operation, and others.
5	R5T	Thermistor (Subcooling heat exchanger gas pipe: Tsh)	Used to detect gas pipe temperature on the evaporation side of subcooling heat exchanger, keep the superheated degree at the outlet of subcooling heat exchanger constant, and others.

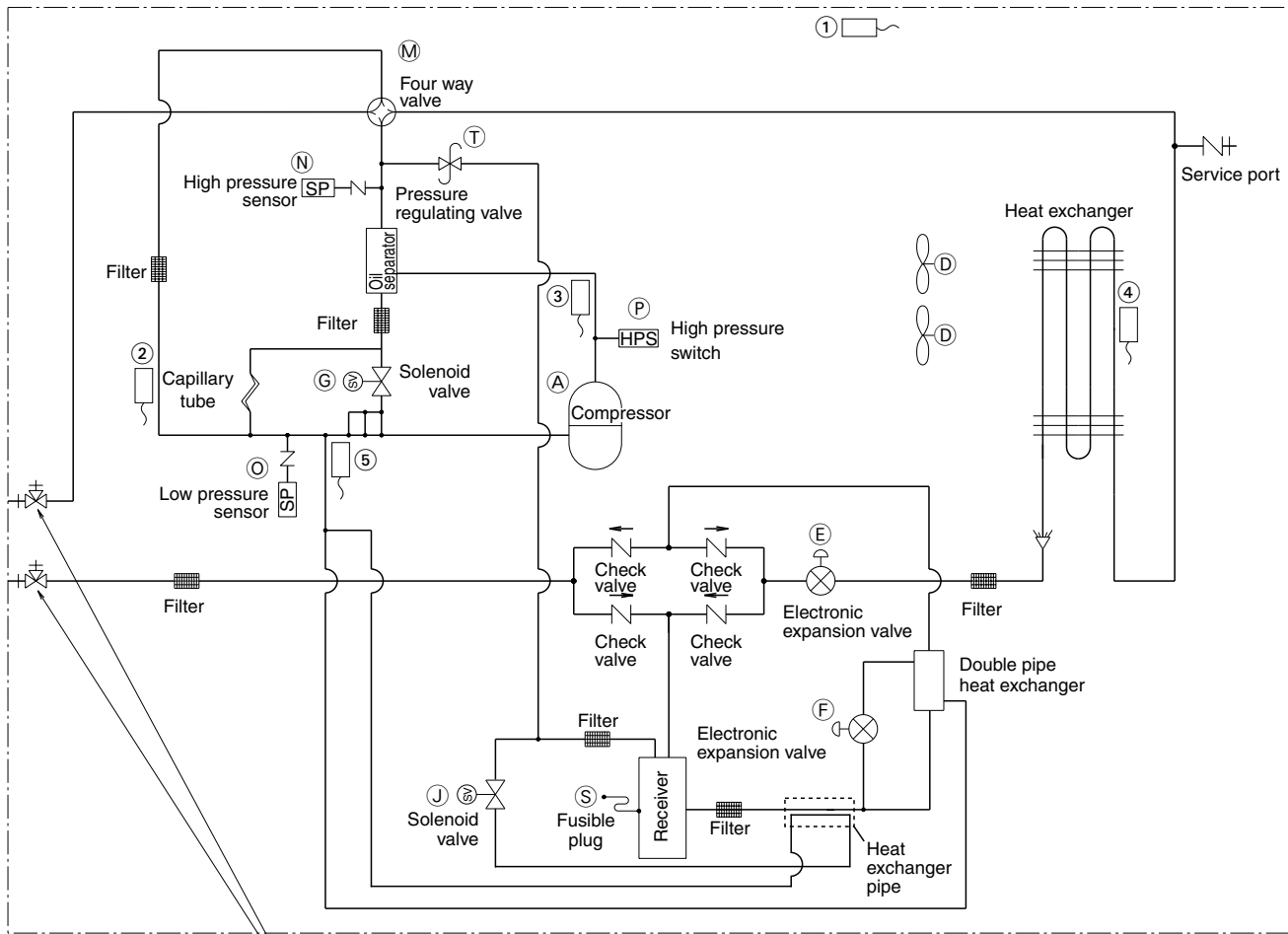

Stop valve (With service port on field piping side ϕ 6.4mm flare connection)

C : 3D047385

2. Functional Parts Layout

2.1 RXYMQ36-48M

Birds-eye view

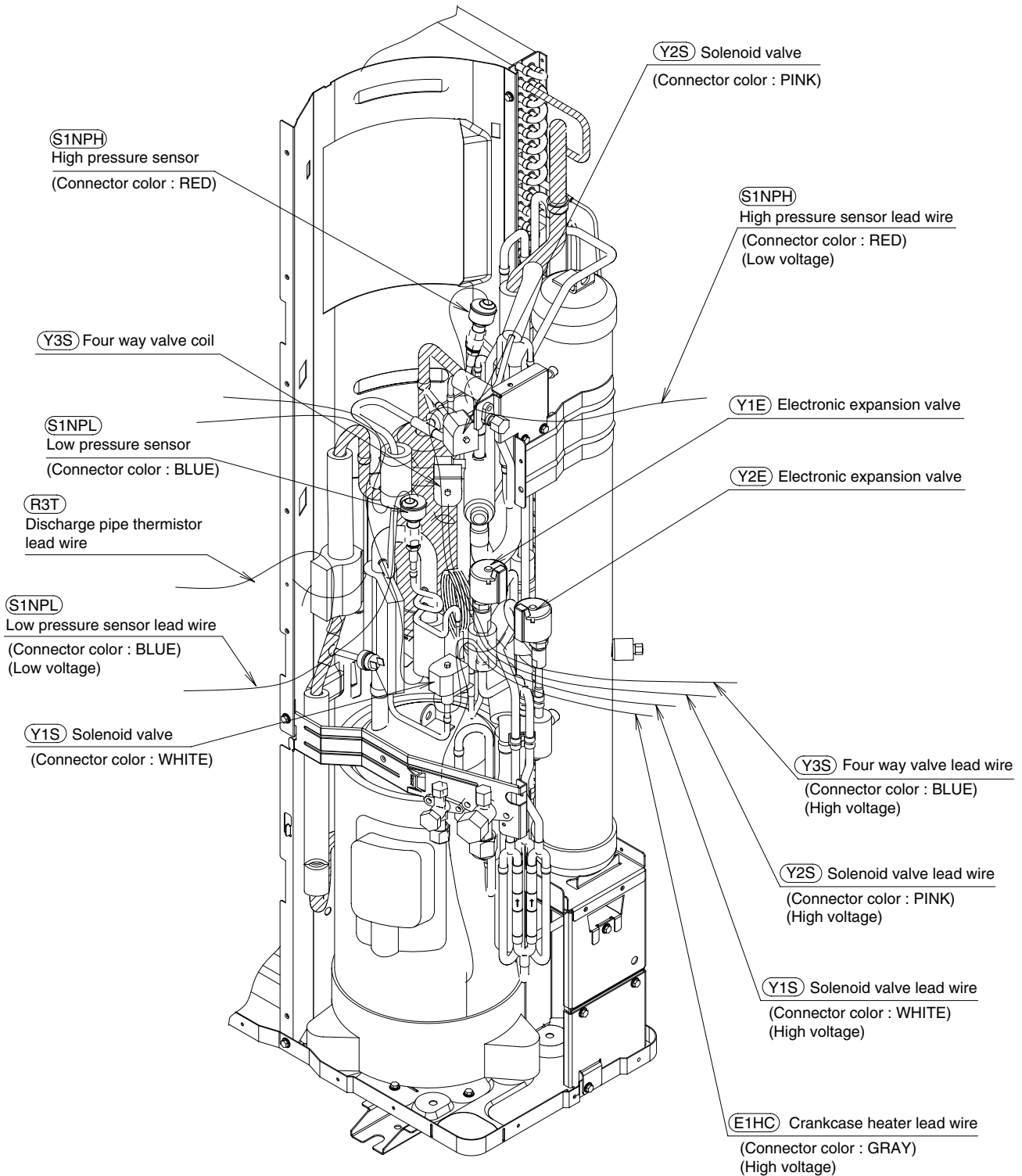

1PN06261B

Part 5

Function

1. Operation Mode	28
2. Basic Control.....	29
2.1 Normal Operation.....	29
2.2 Compressor PI Control	30
2.3 Electronic Expansion Valve PI Control	31
2.4 Cooling Operation Fan Control	32
3. Special Control.....	33
3.1 Startup Control.....	33
3.2 Oil Return Operation	34
3.3 Defrosting Operation.....	36
3.4 Pump-down Residual Operation	37
3.5 Restart Standby	38
3.6 Stopping Operation	39
3.7 Pressure Equalization Prior to Startup.....	40
4. Protection Control	41
4.1 High Pressure Protection Control	41
4.2 Low Pressure Protection Control	42
4.3 Discharge Pipe Protection Control.....	43
4.4 Inverter Protection Control	44
5. Other Control	45
5.1 Demand Operation.....	45
5.2 Heating Operation Prohibition.....	45
6. Outline of Control (Indoor Unit).....	46
6.1 Drain Pump Control	46
6.2 Louver Control for Preventing Ceiling Dirt	48
6.3 Thermostat Sensor in Remote Controller	49
6.4 Freeze Prevention.....	51
6.5 View of Operations of Swing Flaps.....	52

1. Operation Mode

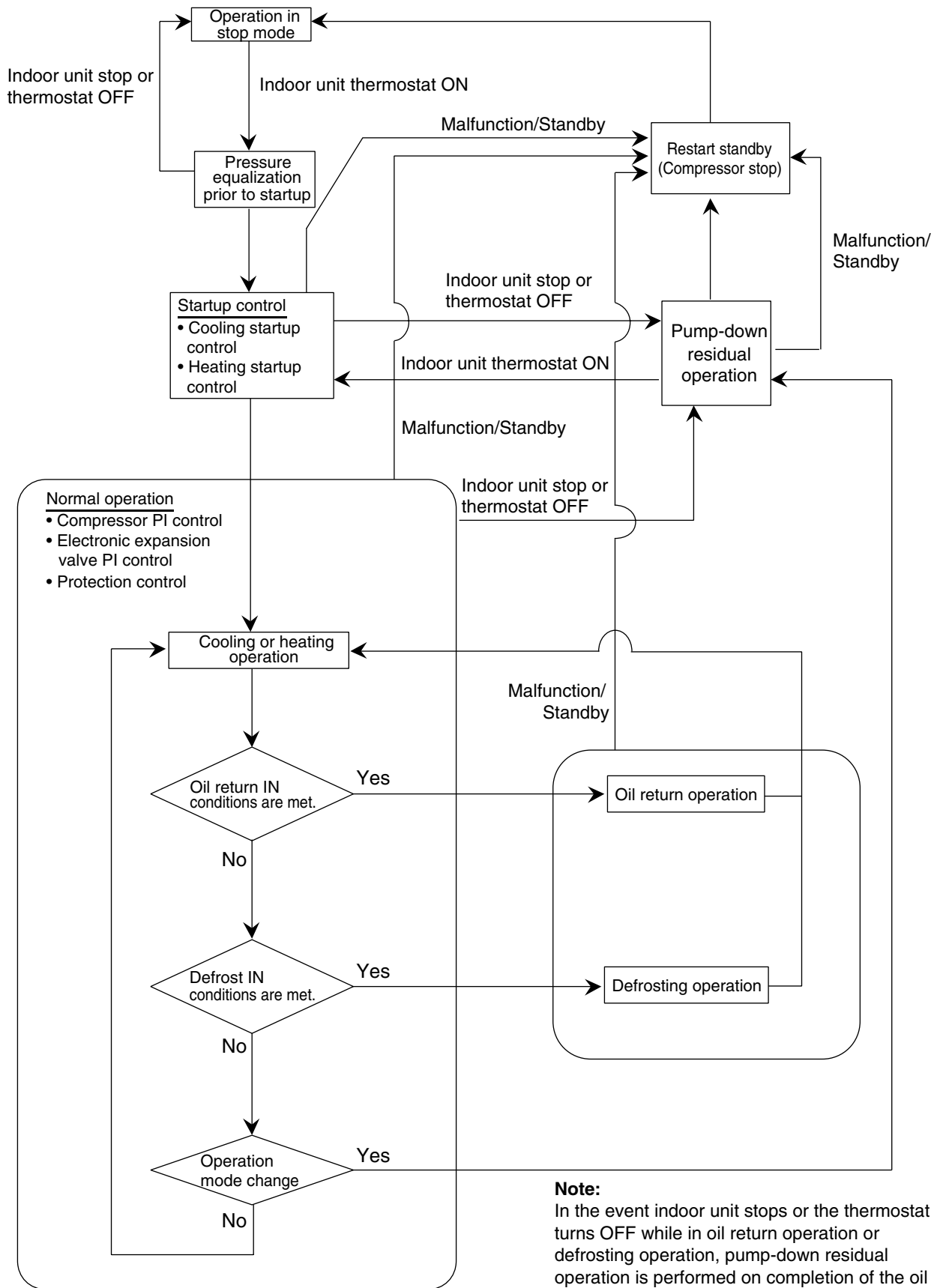

Note:
In the event indoor unit stops or the thermostat turns OFF while in oil return operation or defrosting operation, pump-down residual operation is performed on completion of the oil return operation or defrosting operation.

(V3152)

2. Basic Control

2.1 Normal Operation

■ Cooling Operation

Actuator	Operation	Remarks
Compressor	Compressor PI control	Used for high pressure protection control, low pressure protection control, discharge pipe temperature protection control, and compressor operating frequency upper limit control with inverter protection control.
Outdoor unit fan	Cooling fan control	—
Four way valve	OFF	—
Main electronic expansion valve (EV1)	1400 pls	—
Subcooling electronic expansion valve (EV2)	PI control	—
Hot gas bypass valve (SVP)	OFF	This valve turns on with low pressure protection control.
Receiver gas discharging valve (SVG)	OFF	—

■ Heating Operation

Actuator	Operation	Remarks
Compressor	Compressor PI control	Used for high pressure protection control, low pressure protection control, discharge pipe temperature protection control, and compressor operating frequency upper limit control with inverter protection control.
Outdoor unit fan	STEP8	The fan step changes to STEP1 with high pressure > 454 psi.
Four way valve	ON	—
Main electronic expansion valve (EV1)	PI control	—
Subcooling electronic expansion valve (EV2)	0 pls	—
Hot gas bypass valve (SVP)	OFF	This valve turns on with low pressure protection control.
Receiver gas discharging valve (SVG)	OFF	—

* Heating operation is not functional at an outdoor air temperature of 86°FDB or more.

2.2 Compressor PI Control

Compressor PI Control

Carries out the compressor capacity PI control to maintain Te at constant during cooling operation and Tc at constant during heating operation to ensure stable unit performance.

[Cooling operation]

Controls compressor capacity to adjust Te to achieve target value (TeS).

Te setting (Set in Set-up mode 2)

L	M (Normal) (factory setting)	H
37.5	43	48

Te : Low pressure equivalent saturation temperature (°F)

TeS : Target Te value
(Varies depending on Te setting, operating frequency, etc.)

[Heating operation]

Controls compressor capacity to adjust Tc to achieve target value (TcS).

Tc setting

L	M (Normal) (factory setting)	H
109.5	115	120

Tc : High pressure equivalent saturation temperature (°F)

TcS : Target Tc value
(Varies depending on Tc setting, operating frequency, etc.)

RXYMQ36 · 48M

STEP	INV
1	52Hz
2	57Hz
3	62Hz
4	68Hz
5	74Hz
6	81Hz
7	88Hz
8	96Hz
9	104Hz
10	110Hz

STEP	INV
11	116Hz
12	124Hz
13	133Hz
14	143Hz
15	158Hz
16	165Hz
17	177Hz

* Compressors may operate in a pattern other than those listed in above tables subject to the operating conditions.

2.3 Electronic Expansion Valve PI Control

Main Electronic Expansion Valve EV1 Control

Carries out the electronic expansion valve (Y1E) PI control to maintain the evaporator outlet superheated degree (SH) at constant during heating operation to make maximum use of the outdoor unit heat exchanger (evaporator).

$$SH = T_s - T_e$$

SH : Evaporator outlet superheated degree (°F)

T_s : Suction pipe temperature detected by thermistor R2T (°F)

T_e : Low pressure equivalent saturation temperature (°F)

The optimum initial value of the evaporator outlet superheated degree is 5°C, but varies depending on the discharge pipe superheated degree of inverter compressor.

Subcooling Electronic Expansion Valve EV2 Control

Makes PI control of the electronic expansion valve (Y2E) to keep the superheated degree (SH) of the outlet gas pipe on the evaporator side for the full use of the subcooling heat exchanger.

$$SH = T_{sh} - T_e$$

SH : Outlet superheated degree of evaporator (°F)

T_{sh} : Suction pipe temperature detected with the thermistor R5T (°F)

T_e : Low pressure equivalent saturation temperature (°F)

2.4 Cooling Operation Fan Control

In cooling operation with low outdoor air temperature, this control is used to provide the adequate amount of circulation air with liquid pressure secured by high pressure control using outdoor unit fan.

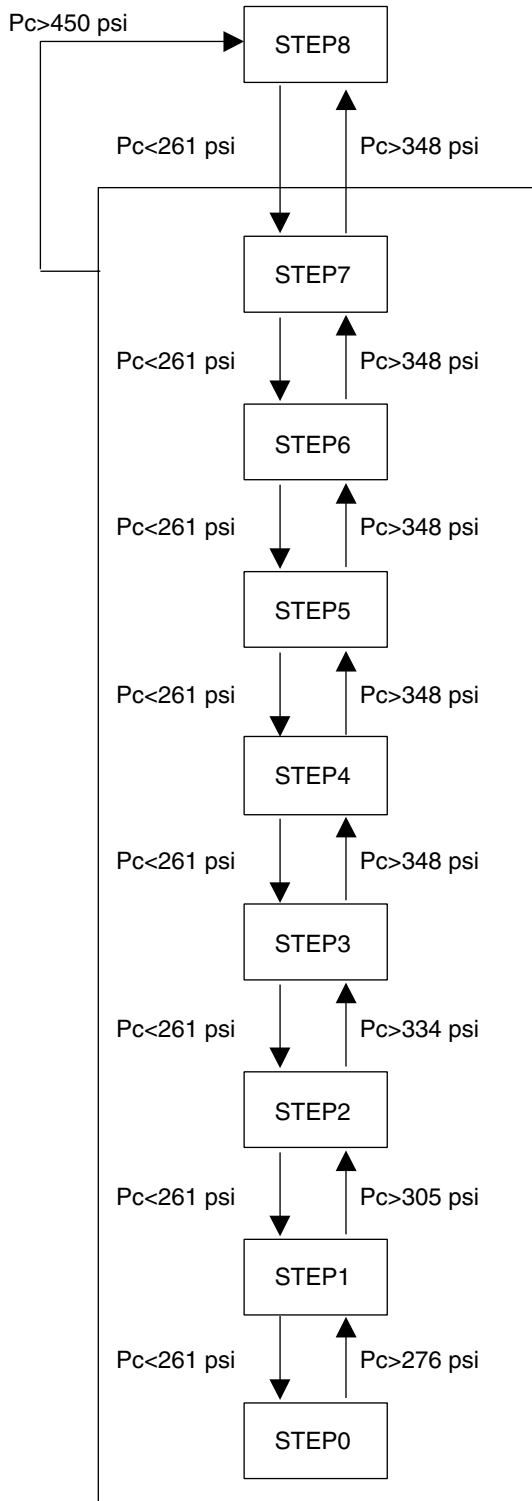

Pc: HP pressure sensor detection value

Fan Steps

Cooling	M1F	M2F
STEP0	0 rpm	0 rpm
STEP1	250 rpm	0 rpm
STEP2	400 rpm	0 rpm
STEP3	285 rpm	250 rpm
STEP4	360 rpm	325 rpm
STEP5	445 rpm	410 rpm
STEP6	580 rpm	545 rpm
STEP7	715 rpm	680 rpm
STEP8	850 rpm	815 rpm

Reference

Heating	M1F	M2F
STEP1	250rpm	0 rpm
STEP8	850 rpm	815rpm

There are 2 steps in heating operation.

(V3172)

3. Special Control

3.1 Startup Control

On activation, following control is performed to lighten load of the compressor by back liquid and the like. Also, the position of the four way valve is defined.

3.1.1 Startup Control in Cooling Operation

Actuator	Operation	Remarks
Compressor	Differential pressure control	Compressor operating frequency increases by 2 step / 20 sec. until $P_c - P_e > 58$ psi.
Outdoor unit fan	High pressure control	Initial fan speed is set to STEP 0. 1-step increase with $P_c > 305$ psi 1-step decrease with $P_c < 261$ psi
Four way valve	OFF	—
Main electronic expansion valve (EV1)	1400 pls	—
Subcooling electronic expansion valve (EV2)	0 pls	—
Hot gas bypass valve (SVP)	ON	—
Receiver gas discharging valve (SVG)	OFF	—
Ending conditions	or $\left[\begin{array}{l} \bullet 230 \text{ sec.} \\ \bullet P_c - P_e > 58 \text{ psi} \\ \bullet 45 \text{ sec.} \end{array} \right. \&$	

3.1.2 Startup Control in Heating Operation (H/P model only)

Actuator	Operation	Remarks
Compressor	Differential pressure control	Compressor operating frequency increases by 2 step / 20 sec. until $P_c - P_e > 58$ psi
Outdoor unit fan	STEP8	—
Four way valve	ON	—
Main electronic expansion valve (EV1)	180 pls	—
Subcooling electronic expansion valve (EV2)	0 pls	—
Hot gas bypass valve (SVP)	ON	—
Receiver gas discharging valve (SVG)	OFF	—
Ending conditions	or $\left[\begin{array}{l} \bullet 145 \text{ sec.} \\ \bullet P_c - P_e > 58 \text{ psi} \\ \bullet 15 \text{ sec.} \end{array} \right. \&$	

3.2 Oil Return Operation

Oil flown from the compressor to the side of system is collected by oil-returning operation, in case of that oil in the compressor runs down.

3.2.1 Oil Return Operation in Cooling Operation

[Conditions to start]

The cooling oil-returning operation is started referring following conditions.

- Integrated amount of displaced oil
- Timer

(After the power is turned on, integrated operating-time is 2 hours and subsequently every 8 hours.)

In addition, integrated amount of displaced oil is derived from Tc, Te, and the compressor load.

Outdoor unit actuator	Oil return preparation operation	Oil return operation	Post-oil-return operation
Compressor	Upper limit control	124 Hz	124 Hz
Outdoor unit fan	Fan control	Fan control	Fan control
Four way valve	OFF	OFF	OFF
Main electronic expansion valve (EV1)	1400 pls	1400 pls	1400 pls
Subcooling electronic expansion valve (EV2)	SH control	0 pls	0 pls
Hot gas bypass valve (SVP)	OFF	ON	ON
Receiver gas discharging valve (SVG)	OFF	OFF	OFF
Ending conditions	20 sec.	or { <ul style="list-style-type: none"> • 6 min. • $T_s - T_e < 5$ 	3 min.

Indoor unit actuator		Cooling oil return operation
Fan	Thermostat ON unit	Set Air Volume
	Stopping unit	OFF
	Thermostat OFF unit	OFF
Electronic expansion valve	Thermostat ON unit	Normal opening
	Stopping unit	200 pls
	Thermostat OFF unit	200 pls

3.2.2 Oil Return Operation in Heating Operation

[Conditions to start]

The heating oil-returning operation is started referring following conditions.

- Integrated amount of displaced oil
- Timer

(After the power is turned on, integrated operating-time is 2 hours and subsequently every 8 hours.)

In addition, integrated amount of displaced oil is derived from T_c , T_e , and the compressor load.

Outdoor Unit Actuator	Oil return preparation operation	Oil return operation	Post-oil-return operation
Compressor	Upper limit control	124 Hz	2-step increase from 52 Hz to ($P_c - P_e > 58$ psi) time
Outdoor unit fan	STEP8	OFF	STEP8
Four way valve	ON	OFF	ON
Main electronic expansion valve (EV1)	SH control	1400 pls	200~400 pls
Subcooling electronic expansion valve (EV2)	0 pls	0 pls	0 pls
Hot gas bypass valve (SVP)	OFF	ON	ON
Receiver gas discharging valve (SVG)	ON	ON	OFF
Ending conditions	130 sec.	or $\left[\begin{array}{l} \bullet 6 \text{ min.} \\ \bullet T_s - T_e < 5 \end{array} \right.$	or $\left[\begin{array}{l} \bullet 160 \text{ sec.} \\ \bullet P_c - P_e > 58 \text{ psi} \end{array} \right.$

* From the preparing oil-returning operation to the oil-returning operation, and from the oil-returning operation to the operation after oil-returning, the compressor stops for 1 minute to reduce noise on changing of the four way valve.

Indoor unit actuator		Heating oil return operation
Fan	Thermostat ON unit	OFF
	Stopping unit	OFF
	Thermostat OFF unit	OFF
Electronic expansion valve	Thermostat ON unit	500 pls
	Stopping unit	500 pls
	Thermostat OFF unit	500 pls

3.3 Defrosting Operation

The defrost operation is performed to solve frost on the outdoor unit heat exchanger when heating, and the heating capacity is recovered.

[Conditions to start]

The defrost operation is started referring following conditions.

- Outdoor heat exchanger heat transfer co-efficiency
- Temperature of heat-exchange (Tb)
- Timer (2 hours at the minimum)

In addition, outdoor heat-exchange co-efficiency is derived from Tc, Te, and the compressor load.

Outdoor unit actuator	Defrost preparation operation	Defrost operation	Post Defrost operation
Compressor	52 Hz	177 Hz	2-step increase from 52 Hz to (Pc - Pe>58 psi) every 20 sec.
Outdoor unit fan	STEP8	OFF	STEP8
Four way valve	ON	OFF	ON
Main electronic expansion valve (EV1)	SH control	1400 pls	200~400 pls
Subcooling electronic expansion valve (EV2)	0 pls	0 pls	0 pls
Hot gas bypass valve (SVP)	OFF	ON	ON
Receiver gas discharging valve (SVG)	ON	ON	OFF
Ending conditions	130 sec.	or [<ul style="list-style-type: none"> • 15 min. • Tb >51.8°F 	or [<ul style="list-style-type: none"> • 160 sec. • Pc - Pe>58 psi

* From the preparing operation to the defrost operation, and from the defrost operation to the operation after defrost, the compressor stops for 1 minute to reduce noise on changing of the four way valve.

Indoor unit actuator		During defrost
Fan	Thermostat ON unit	OFF
	Stopping unit	OFF
	Thermostat OFF unit	OFF
Electronic expansion valve	Thermostat ON unit	500 pls
	Stopping unit	500 pls
	Thermostat OFF unit	500 pls

3.4 Pump-down Residual Operation

When activating compressor, if the liquid refrigerant remains in the heat-exchanger, the liquid enters into the compressor and dilutes oil therein resulting in decrease of lubricity.

Therefore, the pump-down residual operation is performed to collect the refrigerant in the heat-exchanger when the compressor is down.

3.4.1 Pump-down Residual Operation in Cooling Operation

Actuator	Master unit operation
Compressor	124 Hz
Outdoor unit fan	Fan control
Four way valve	OFF
Main electronic expansion valve (EV1)	2000 pls
Subcooling electronic expansion valve (EV2)	0 pls
Hot gas bypass valve (SVP)	OFF
Receiver gas discharging valve (SVG)	ON → OFF
Ending conditions	or <ul style="list-style-type: none"> • 30 sec. • Pe<73 psi • Td>230°F

3.4.2 Pump-down Residual Operation in Heating Operation

Actuator	Master unit operation
Compressor	124 Hz
Outdoor unit fan	STEP8
Four way valve	ON
Main electronic expansion valve (EV1)	0 pls
Subcooling electronic expansion valve (EV2)	0 pls
Hot gas bypass valve (SVP)	OFF
Receiver gas discharging valve (SVG)	ON → OFF
Ending conditions	or <ul style="list-style-type: none"> • 3 min. • Pe<36 psi • Td>230°F

3.5 Restart Standby

Restart is stood by force to prevent frequent power-on/off and to equalize pressure in the refrigerant system.

Actuator	Operation	Remarks
Compressor	OFF	—
Outdoor unit fan	Ta>86°F: STEP4 Ta≤86°F: OFF	—
Four way valve	Keep former condition.	—
Main electronic expansion valve (EV1)	0 pls	—
Subcooling electronic expansion valve (EV2)	0 pls	—
Hot gas bypass valve (SVP)	ON	—
Receiver gas discharging valve (SVG)	OFF	—
Ending conditions	5 min.	—

3.6 Stopping Operation

Operation of the actuator when the system is down, is cleared up.

3.6.1 When System is in Stop Mode

Actuator	Operation
Compressor	OFF
Outdoor unit fan	OFF
Four way valve	Keep former condition.
Main electronic expansion valve (EV1)	0 pls
Subcooling electronic expansion valve (EV2)	0 pls
Hot gas bypass valve (SVP)	OFF
Receiver gas discharging valve (SVG)	OFF
Ending conditions	Indoor unit thermostat is turned ON.

3.7 Pressure Equalization Prior to Startup

Before activating the compressor, the activation load is lightened by equalization across the compressor. In addition, inverters turn on electricity and capacitors are charged.

Actuator	Operation	Remarks
Compressor	OFF	—
Outdoor unit fan	Cooling:OFF Heating:Ta>78.8°F; STEP8, Ta≤78.8°F; OFF	—
Four way valve	Keep former condition.	—
Main electronic expansion valve (EV1)	0 pls	—
Subcooling electronic expansion valve (EV2)	0 pls	—
Hot gas bypass valve (SVP)	ON	—
Receiver gas discharging valve (SVG)	OFF	—
Ending conditions	or [<ul style="list-style-type: none"> • 3 min. • Pc-Pe<29 psi 	—

4. Protection Control

4.1 High Pressure Protection Control

This high pressure protection control is used to prevent the activation of protection devices due to abnormal increase of high pressure and to protect compressors against the transient increase of high pressure.

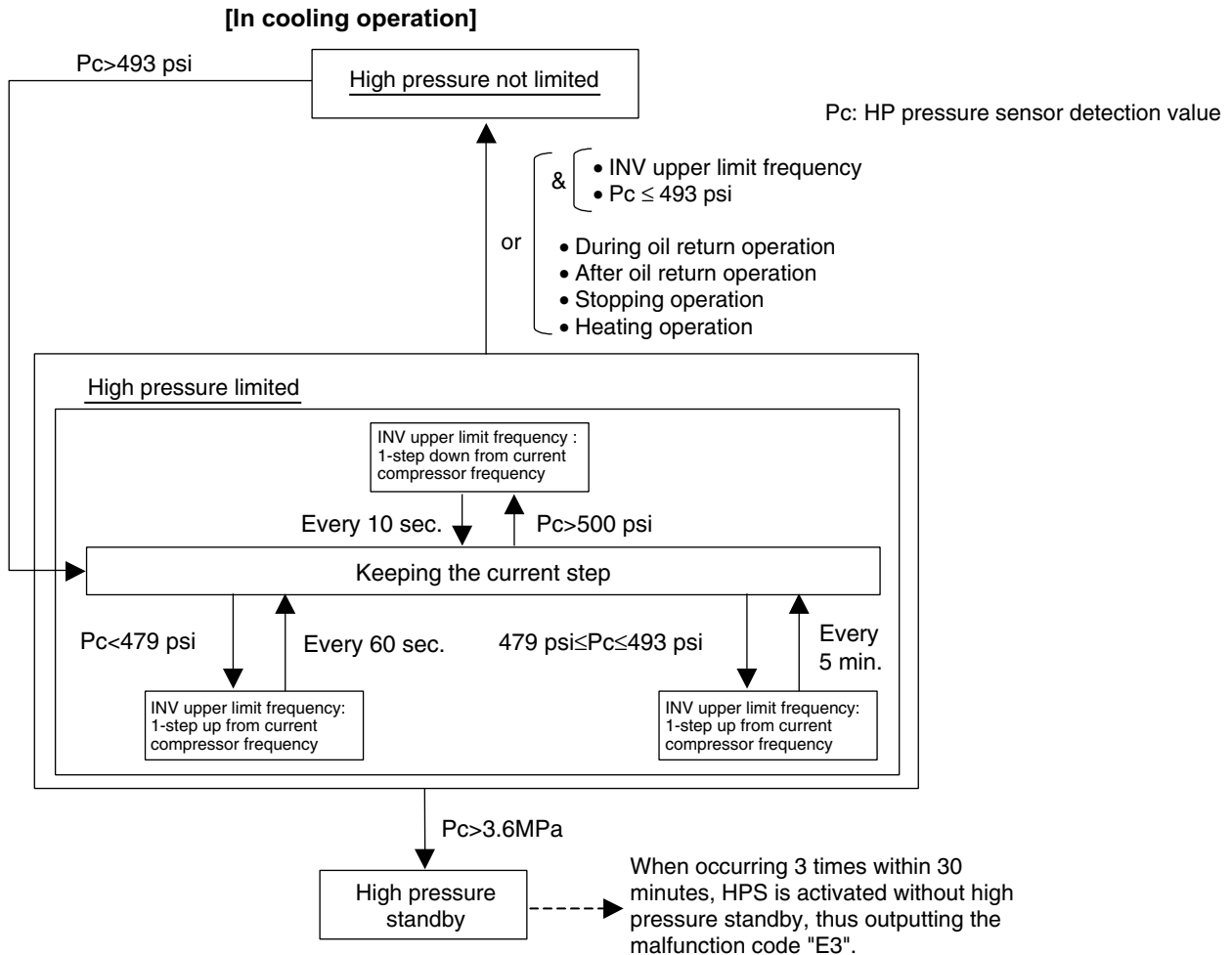

(V3173)

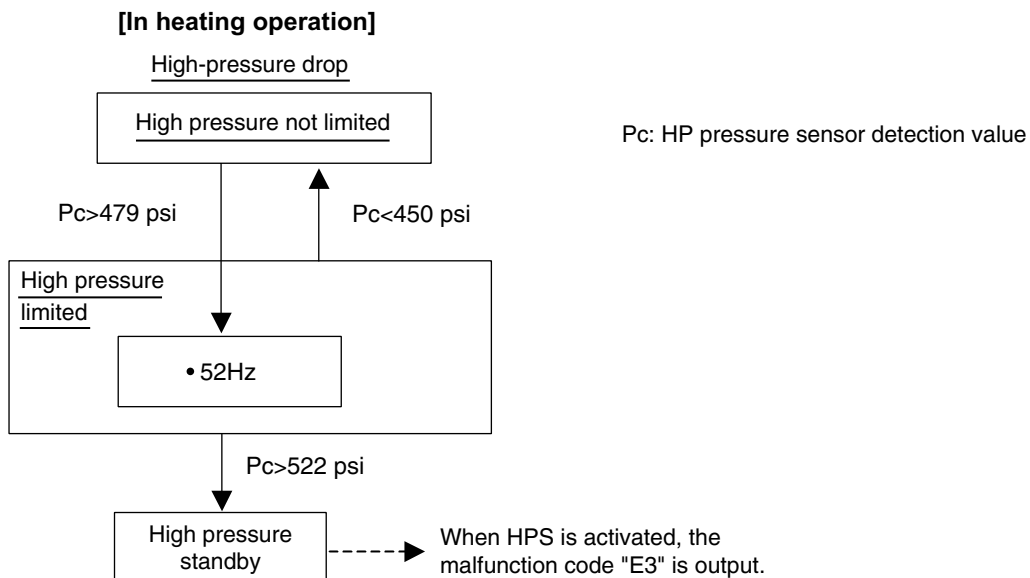

(V3174)

4.2 Low Pressure Protection Control

This low pressure protection control is used to protect compressors against the transient decrease of low pressure.

[In cooling operation]

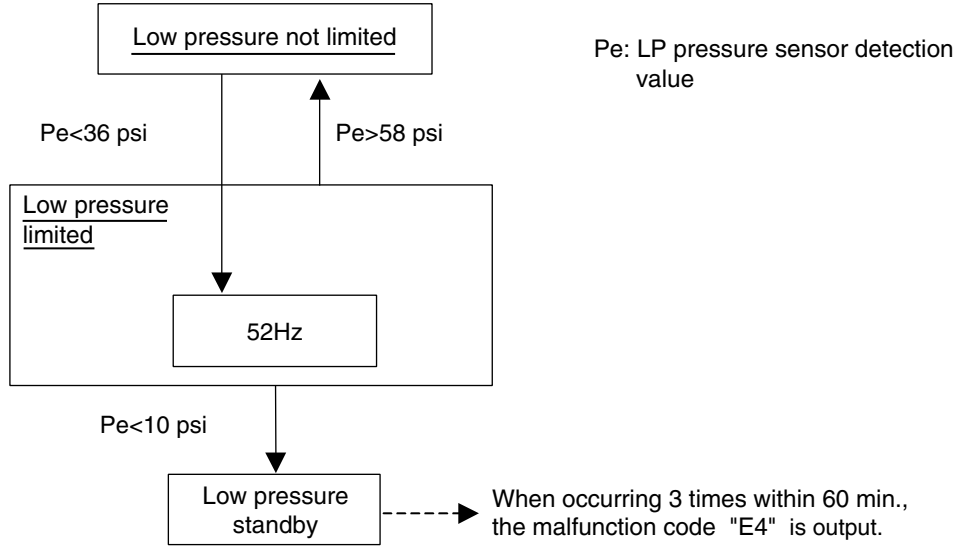

(V3175)

[In heating operation]

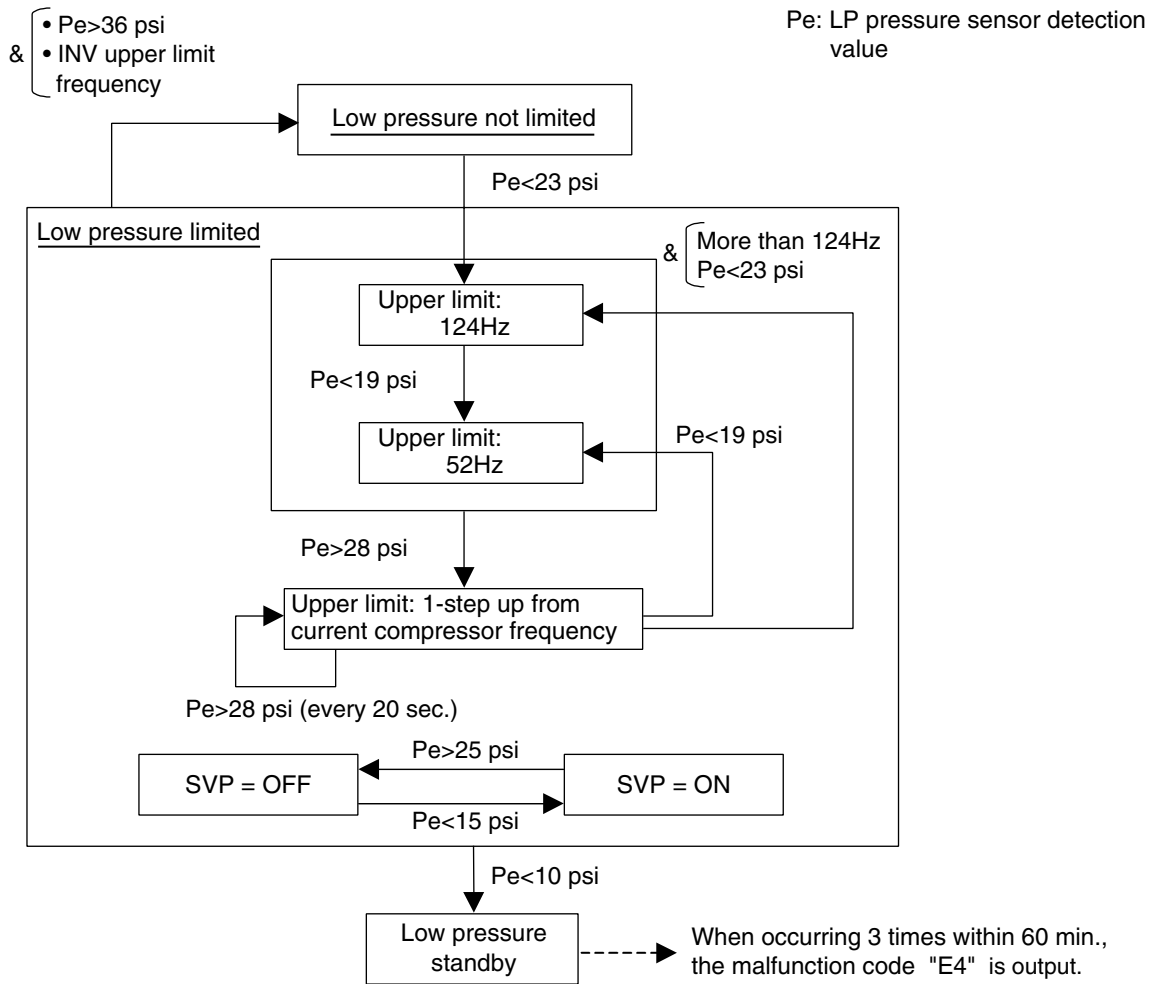

(V3176)

4.3 Discharge Pipe Protection Control

This discharge pipe protection control is used to protect the compressor internal temperature against a malfunction or transient increase of discharge pipe temperature.

[INV compressor]

HTdi : Value of INV compressor discharge pipe temperature (Tdi) compensated with outdoor air temperature
 Tp : Value of compressor port temperature calculated by Tc and Te, and suction superheated degree.

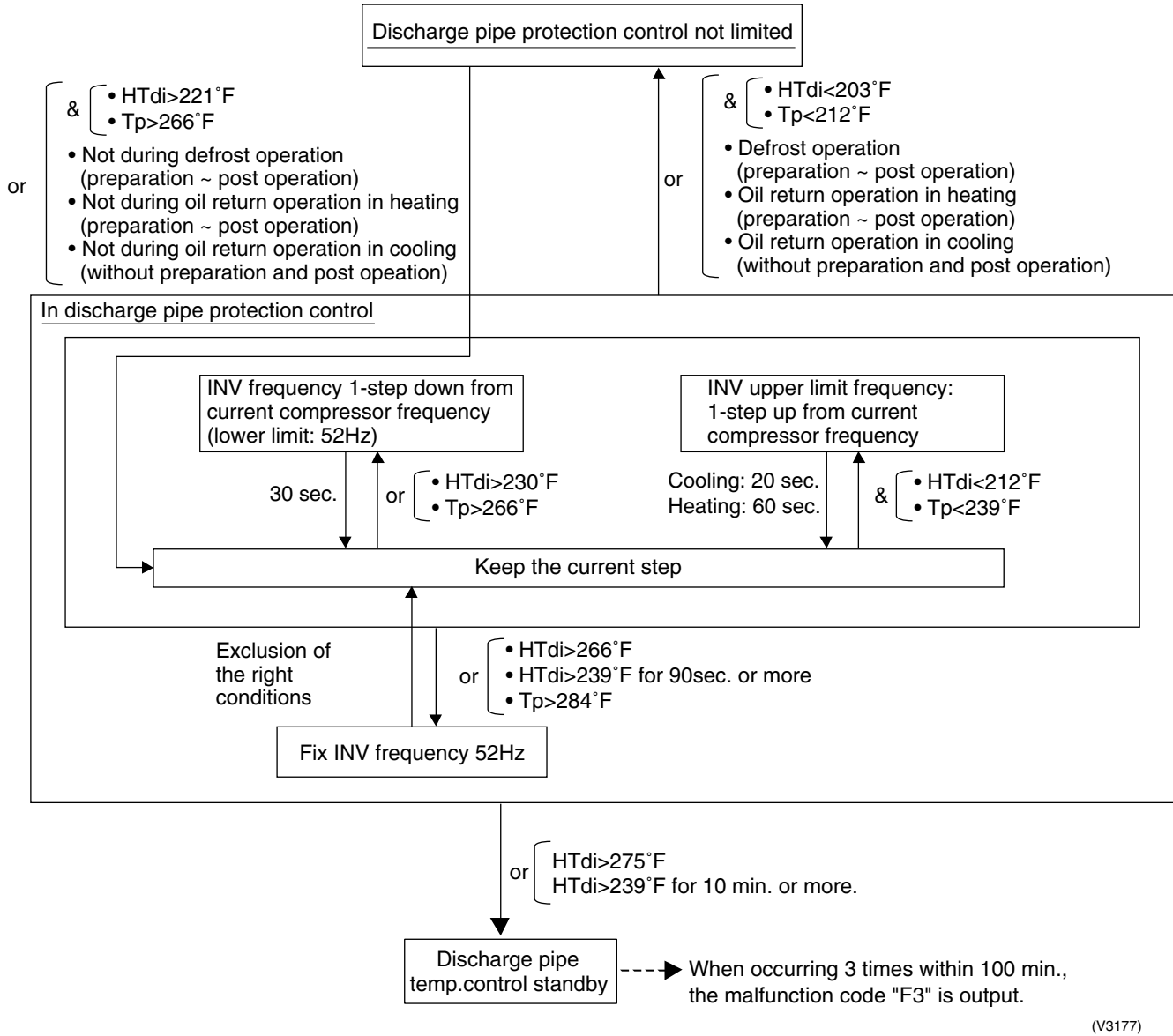

(V3177)

4.4 Inverter Protection Control

Inverter current protection control and inverter fin temperature control are performed to prevent tripping due to a malfunction, or transient inverter overcurrent, and fin temperature increase.

[Inverter overcurrent protection control]

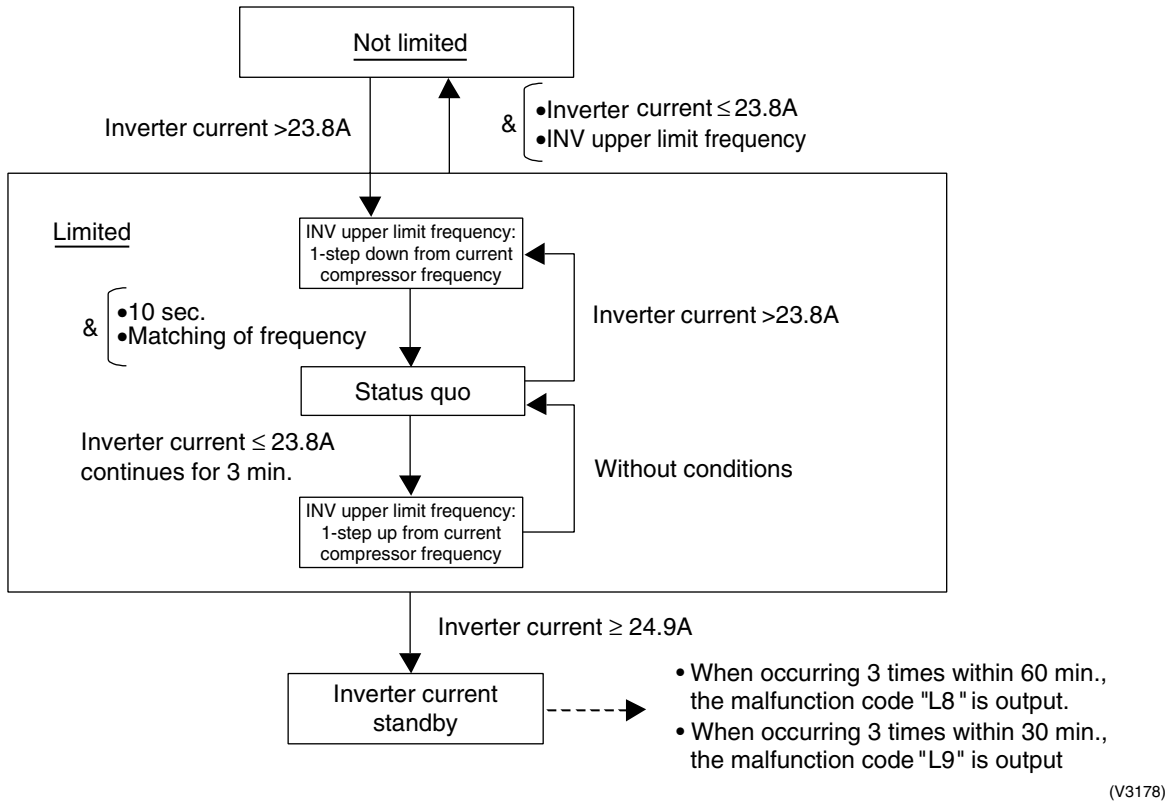

[Inverter fin temperature control]

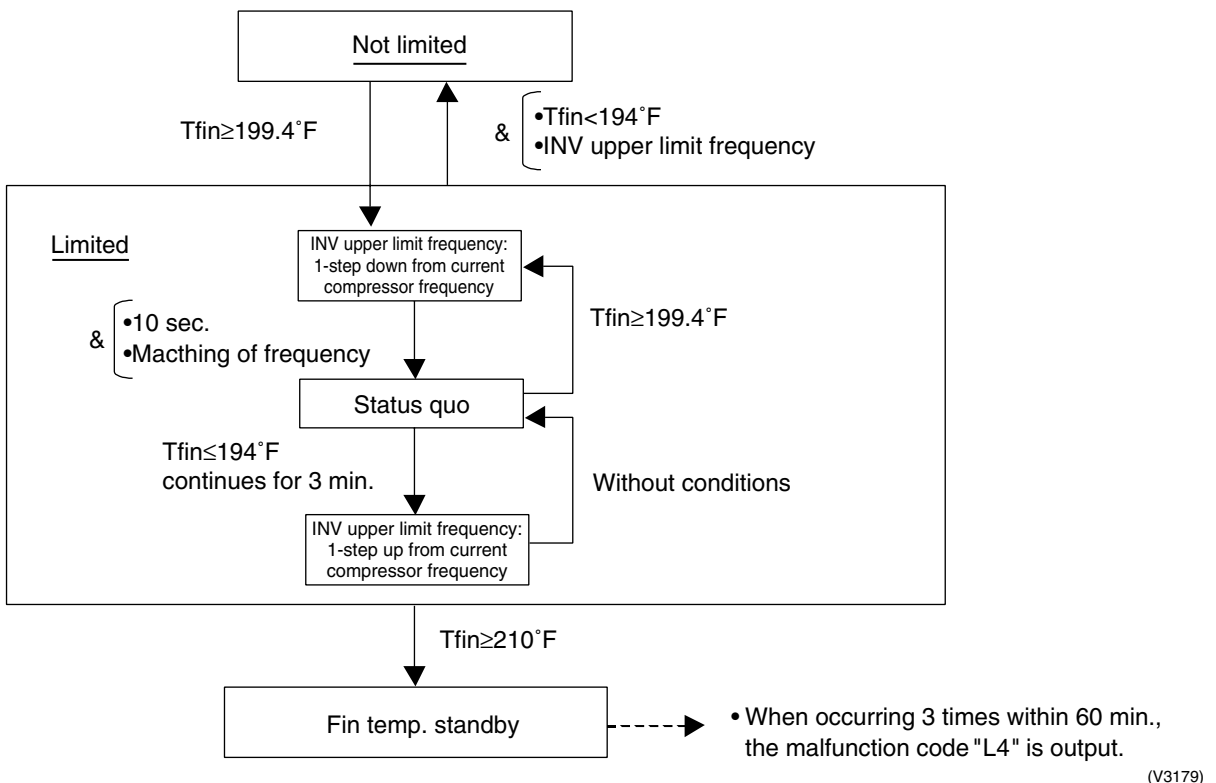

5. Other Control

5.1 Demand Operation

In order to save the power consumption, the capacity of outdoor unit is saved with control forcibly by using "Demand 1 Setting" or "Demand 2 Setting".

To operate the unit with this mode, additional setting of "Continuous Demand Setting" or external input by external control adaptor is required.

[Demand 1 setting]

Setting	Standard for upper limit of power consumption
Demand 1 setting 1	Approx. 60%
Demand 1 setting 2 (factory setting)	Approx. 70%
Demand 1 setting 3	Approx. 80%

[Demand 2 setting]

Setting	Standard for upper limit of power consumption
Demand 2 setting 2 (factory setting)	Approx. 40%

★ Other protection control functions have precedence over the above operation.

5.2 Heating Operation Prohibition

Heating operation is prohibited above 86°FDB outdoor air temperature.

6. Outline of Control (Indoor Unit)

6.1 Drain Pump Control

1. The drain pump is controlled by the ON/OFF buttons (4 button (1) - (4) given in the figure below).

6.1.1 When the Float Switch is Tripped While the Cooling Thermostat is ON:

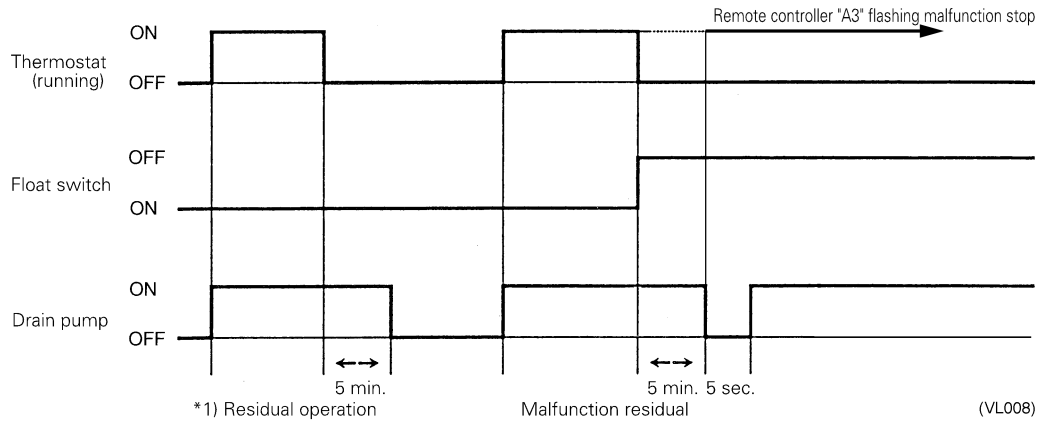

* 1. The objective of residual operation is to completely drain any moisture adhering to the fin of the indoor unit heat exchanger when the thermostat goes off during cooling operation.

6.1.2 When the Float Switch is Tripped While the Cooling Thermostat is OFF:

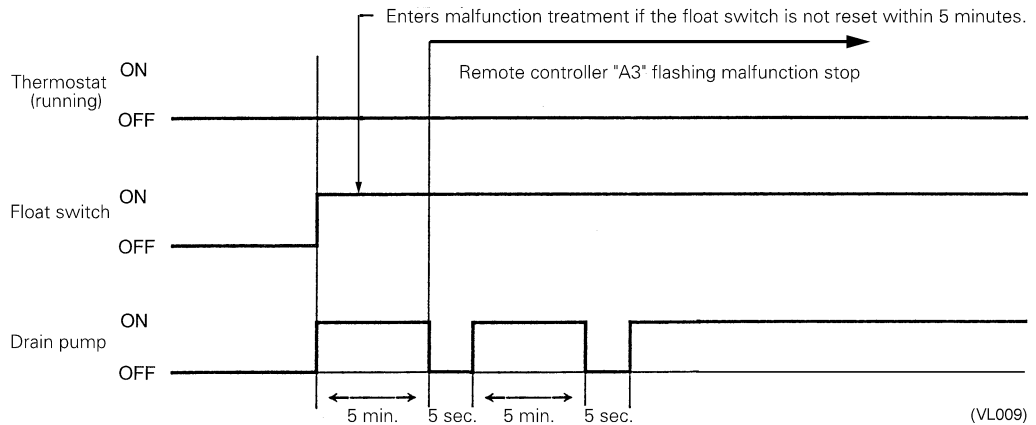

6.1.3 When the Float Switch is Tripped During Heating Operation:

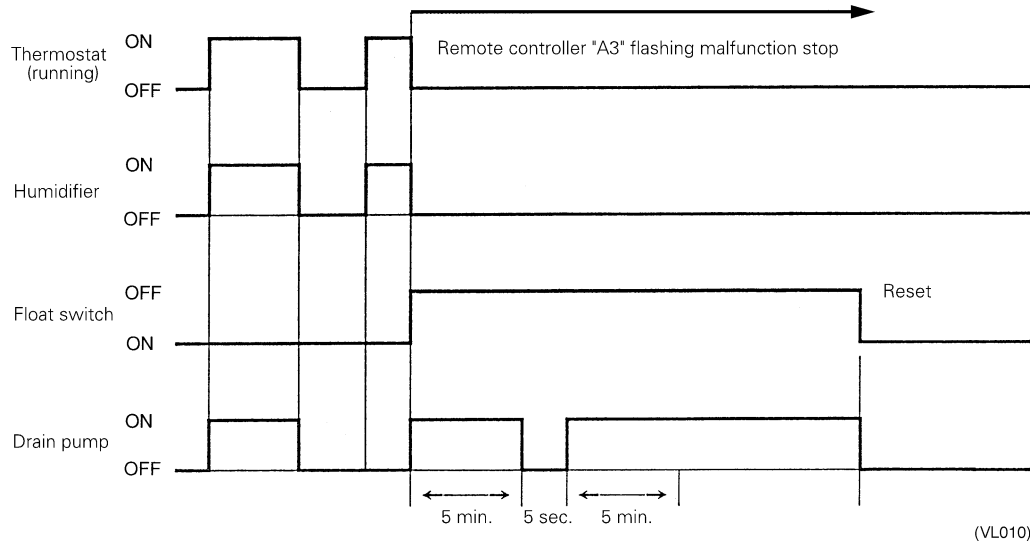

During heating operation, if the float switch is not reset even after the 5 minutes operation, 5 seconds stop, 5 minutes operation cycle ends, operation continues until the switch is reset.

6.1.4 When the Float Switch is Tripped and “AF” is Displayed on the Remote Controller:

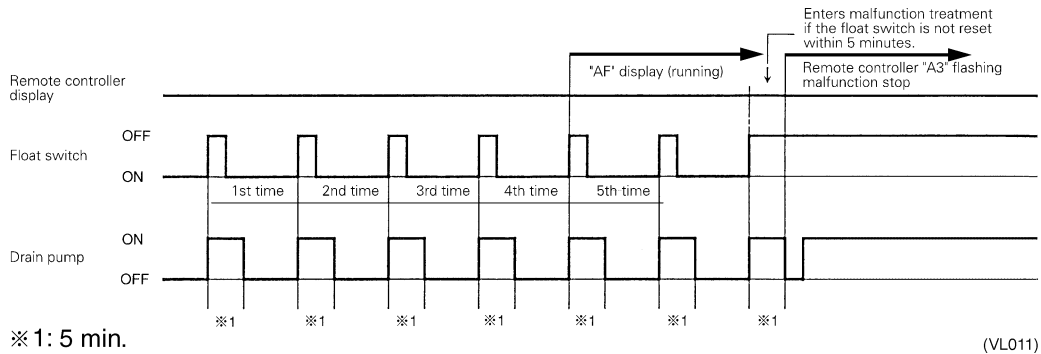

Note:

If the float switch is tripped five times in succession, a drain malfunction is determined to have occurred. “AF” is then displayed as operation continues.

6.2 Louver Control for Preventing Ceiling Dirt

We have added a control feature that allows you to select the range of in which air direction can be adjusted in order to prevent the ceiling surrounding the air discharge outlet of ceiling mounted cassette type units from being soiled.

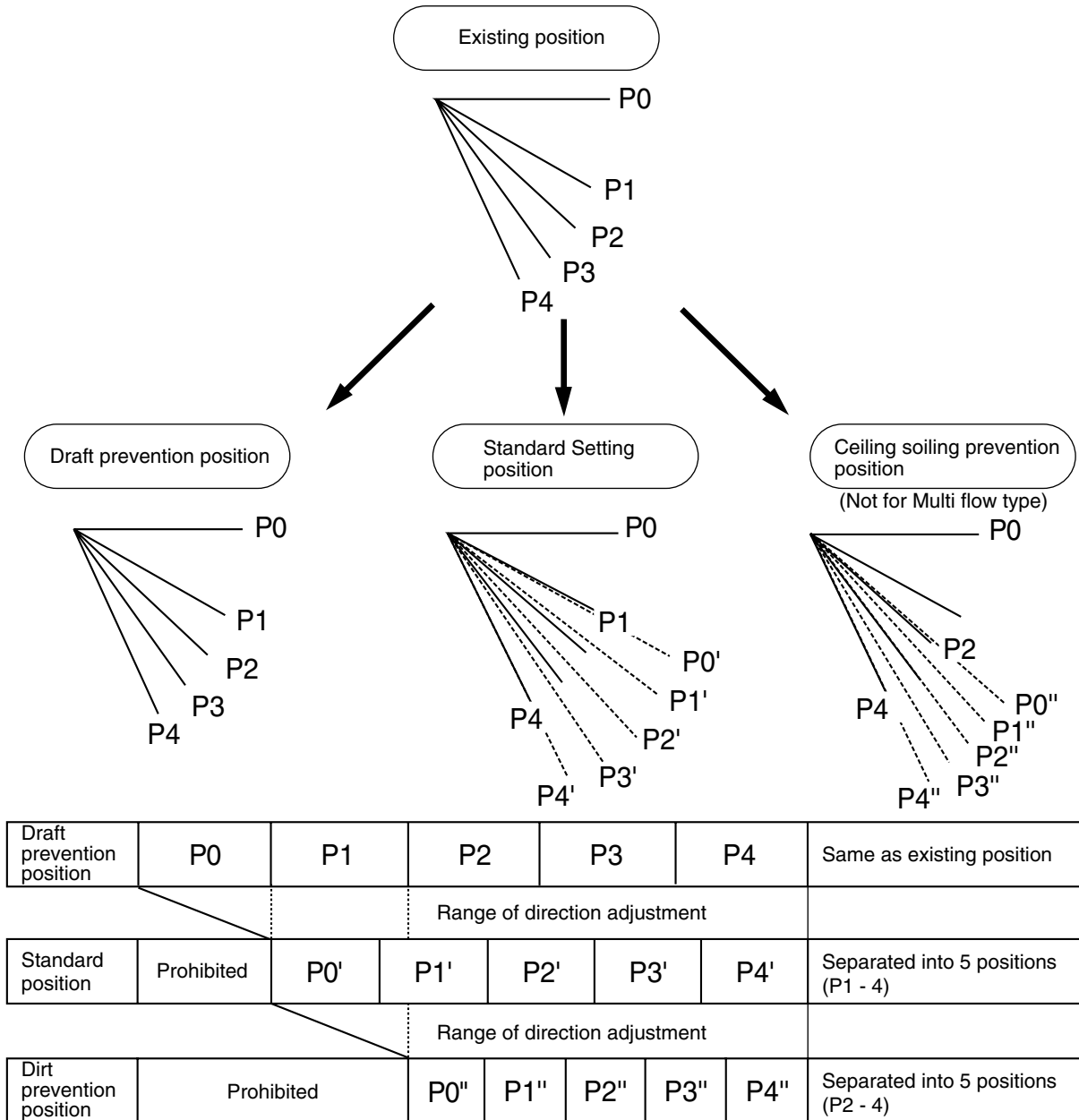

(VL012)

The factory set position is standard position.

6.3 Thermostat Sensor in Remote Controller

Temperature is controlled by both the thermostat sensor in remote controller and air suction thermostat in the indoor unit. (This is however limited to when the field setting for the thermostat sensor in remote controller is set to "Use.")



Note: When OA (outdoor air) is introduced to the air-conditioner with mixed into indoor air, the room temperature may fail to be preset temperature, since TS and TH1 do not enter the area of "use range of remote control thermostat." In such a case, put the remote sensor (optional accessory) in your room, and use it with setting "do not use remote control thermostat."

Cooling

If there is a significant difference in the preset temperature and the suction temperature, fine adjustment control is carried out using a body thermostat sensor, or using the sensor in the remote controller near the position of the user when the suction temperature is near the preset temperature.

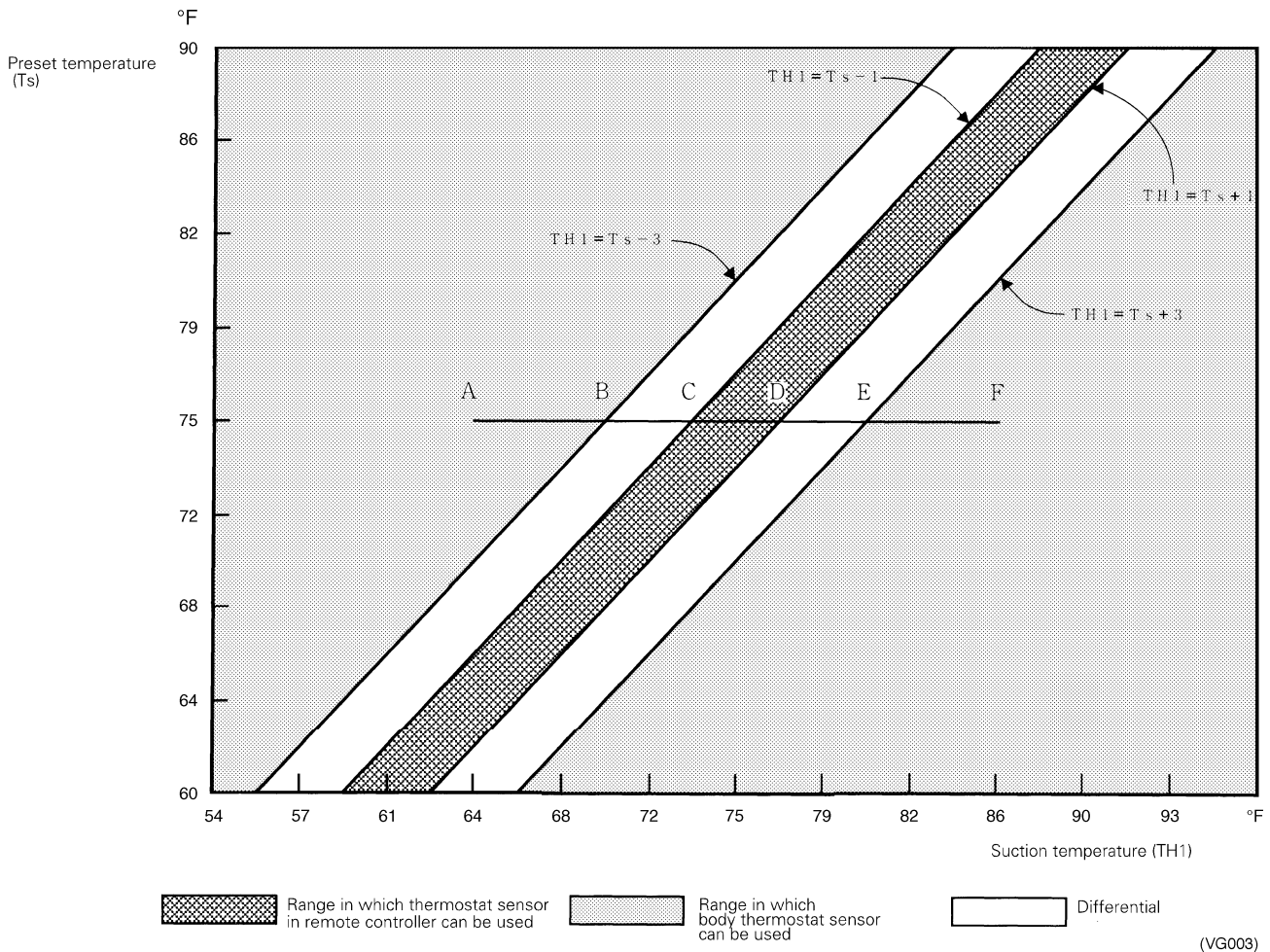

■ **Ex: When cooling**

Assuming the preset temperature in the figure above is 75°F, and the suction temperature has changed from 64°F to 86°F (A → F):

(This example also assumes there are several other air conditioners, the VRV system is off, and that temperature changes even when the thermostat sensor is off.)

Body thermostat sensor is used for temperatures from 64°F to 73°F (A → C).

Remote controller thermostat sensor is used for temperatures from 73°F to 81°F (C → E).

Body thermostat sensor is used for temperatures from 81°F to 86°F (E → F).

And, assuming suction temperature has changed from 86°F to 64°F (F → A):

Body thermostat sensor is used for temperatures from 86°F to 77°F (F → D).

Remote controller thermostat sensor is used for temperatures from 77°F to 70°F (D → B).

Body thermostat sensor is used for temperatures from 70°F to 64°F (B → A).

Heating

When heating, the hot air rises to the top of the room, resulting in the temperature being lower near the floor where the occupants are. When controlling by body thermostat sensor only, the unit may therefore be turned off by the thermostat before the lower part of the room reaches the preset temperature. The temperature can be controlled so the lower part of the room where the occupants are doesn't become cold by widening the range in which thermostat sensor in remote controller can be used so that suction temperature is higher than the preset temperature.

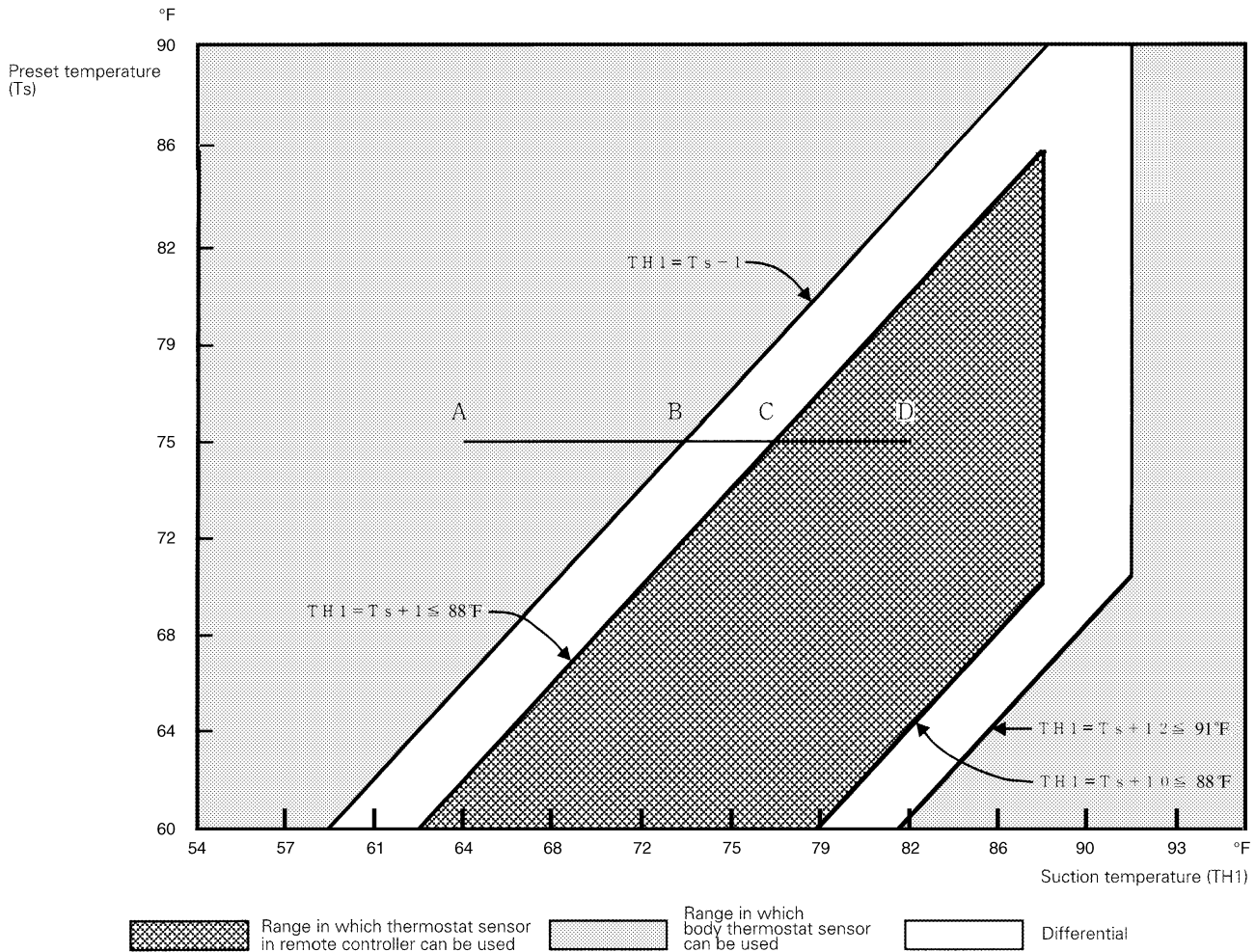

(V2769)

■ **Ex: When heating**

Assuming the preset temperature in the figure above is 75°F, and the suction temperature has changed from 64°F to 82°F (A → D):

(This example also assumes there are several other air conditioners, the VRV system is off, and that temperature changes even when the thermostat sensor is off.)

Body thermostat sensor is used for temperatures from 64°F to 77°F (A → C).

Remote controller thermostat sensor is used for temperatures from 77°F to 82°F (C → D).

And, assuming suction temperature has changed from 82°F to 64°F (D → A):

Remote controller thermostat sensor is used for temperatures from 82°F to 73°F (D → B).

Body thermostat sensor is used for temperatures from 73°F to 64°F (B → A).

6.4 Freeze Prevention

Freeze Prevention by Off Cycle (Indoor Unit)

When the temperature detected by liquid pipe temperature thermistor (R2T) of the indoor unit heat exchanger drops too low, the unit enters freeze prevention operation in accordance with the following conditions, and is also set in accordance with the conditions given below.

Conditions for starting freeze prevention: Temperature is 30°F or less for total of 40 min., or temperature is 23°F or less for total of 10 min.

Conditions for stopping freeze prevention: Temperature is 45°F or more for 10 min. continuously.

Ex: Case where temperature is 23°F or less for total of 10 min.

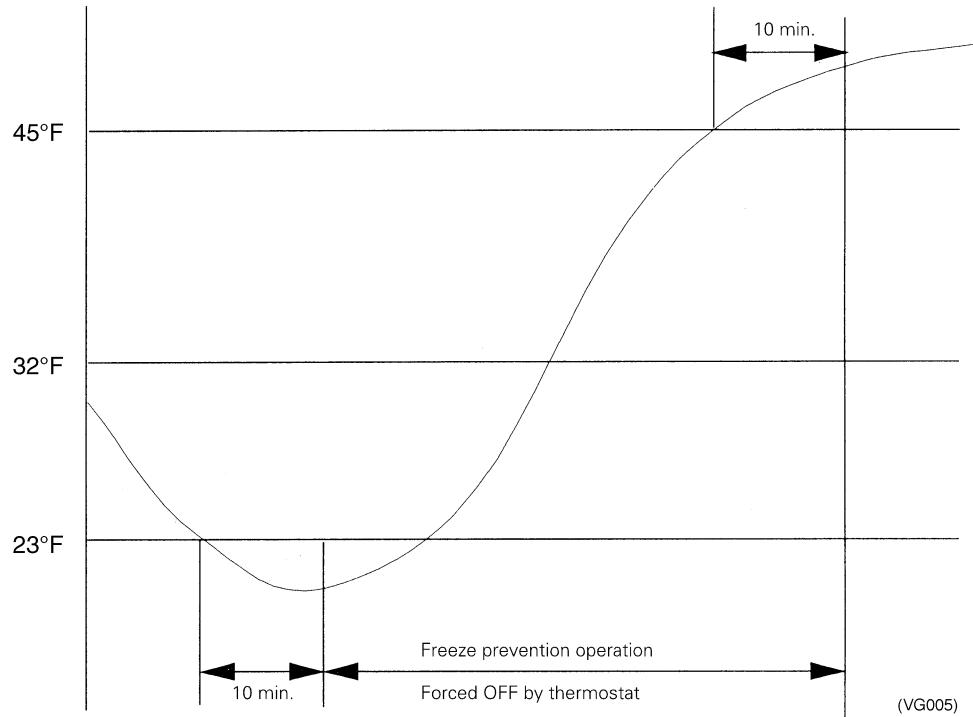

(VG005)

6.5 View of Operations of Swing Flaps

Swing flaps work as following.

			Fan	Flap control			
				FXFQ	FXHQ	FXAQ	
Heating	Hot-start from defrosting	Swinging	OFF	Level	Level	Level	
		Setting the wind direction	OFF	Level	Level	Level	
	Defrosting	Swinging	OFF	Level	Level	Level	
		Setting the wind direction	OFF	Level	Level	Level	
	Thermostat is off	Swinging	LL	Level	Level	Level	
		Setting the wind direction	LL	Level	Level	Level	
	Hot-start from the state that the thermostat is off	Swinging	LL	Level	Level	Level	
		Setting the wind direction	LL	Level	Level	Level	
	Halt	Swinging	OFF	Level	Level	Level	
		Setting the wind direction	OFF	Level	Level	Level	
	Cooling	Thermostat of microcomputer-dry is on	Swinging	L ^{*1}	Swinging	Swinging	Swinging
			Setting the wind direction	L ^{*1}	Set up	Set up	Set up
Thermostat of microcomputer-dry is off		Swinging	OFF or L	Swinging	Swinging	Swinging	
		Setting the wind direction		Set up	Set up	Set up	
Cooling thermostat is off		Swinging	Set up	Swinging	Swinging	Swinging	
		Setting the wind direction	Set up	Set up	Set up	Set up	
Halt		Swinging	OFF	Level	Level	Level	
		Setting the wind direction	OFF	Set up	Level	Level	
Microcomputer is controlled (including the cooling state)		Swinging	L	Swinging	Swinging	Swinging	
		Setting the wind direction	L	Set up	Set up	Set up	

* 1. Only in FXFQ case, L or LL.

Part 6

Test Operation

1. Test Operation	54
1.1 Procedure and Outline	54
1.2 Operation When Power is Turned On.....	57
2. Outdoor Unit PC Board Layout	58
3. Field Setting	59
3.1 Field Setting from Remote Controller.....	59
3.2 Field Setting from Outdoor Unit	70
3.3 Detail of Setting Mode.....	76

1. Test Operation

1.1 Procedure and Outline

Follow the following procedure to conduct the initial test operation after installation.

1.1.1 Check Work Prior to Turn Power Supply On

Check the below items.

- Power wiring
- Control transmission wiring between units
- Earth wire



Check on refrigerant piping



Check on amount of refrigerant charge

- Is the power supply single-phase 208-230V / 60Hz?
- Have you finished a ductwork to drain?
- Have you detach transport fitting?
- Is the wiring performed as specified?
- Are the designated wires used?
- Is the grounding work completed?
 - Use a 500V megger tester to measure the insulation.
 - Do not use a megger tester for other circuits than 200-230V circuit.
- Are the setscrews of wiring not loose?
- Is the electrical component box covered with an insulation cover completely?

- Is pipe size proper? (The design pressure of this product is 580 psi.)
- Are pipe insulation materials installed securely?
 - Liquid and gas pipes need to be insulated. (Otherwise causes water leak.)
- Are respective stop valves on liquid and gas line securely open?

- Is refrigerant charged up to the specified amount?
 - If insufficient, charge the refrigerant from the service port of stop valve on the liquid side with outdoor unit in stop mode after turning power on.
- Has the amount of refrigerant charge been recorded on “Record Chart of Additional Refrigerant Charge Amount”?

(V3180)

1.1.2 Turn Power On

Turn outdoor unit power on.



Turn indoor unit power on.



Carry out field setting on outdoor PC board

- Be sure to turn the power on 6 hours before starting operation to protect compressors.
- Close outside panels of the outdoor unit.

(V3056)

1.1.3 Check Operation

- * During check operation, mount front panel to avoid the misjudging.
- * Check operation is mandatory for normal unit operation.
(When the check operation is not executed, alarm code "U3" will be displayed.)

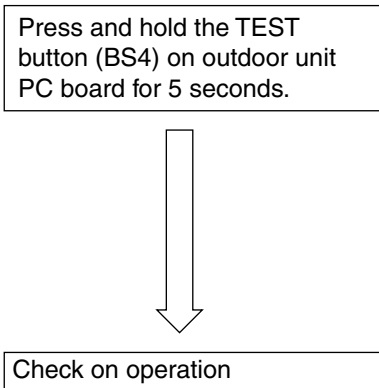

○ The test operation is started automatically.
The following judgements are conducted within 15 minutes (about 30 minutes at the maximum).

- “Check for wrong wiring”
- “Check stop valve for not open”
- “Pipe length automatic judgement”

The following indications are conducted while in test operation.

- LED lamp on outdoor unit PC board — H2P flickers (test operation)
- Remote controller — Indicates “Under Centralized Control” on upper right.
Indicates “Test Operation” on lower left

(V3057)

On completion of test operation, LED on outdoor unit PC board displays the following.
 H3P ON: Normal completion
 H2P and H3P ON: Abnormal completion → Check the indoor unit remote controller for abnormal display and correct it.



Malfunction code

In case of an alarm code displayed on remote controller:

Malfunction code	Nonconformity during installation	Remedial action
E3	The shutoff valves in the outdoor unit remain closed.	Open the shutoff valve on both the gas side and liquid side.
	The refrigerant is overcharged.	Calculate again the required quantity of refrigerant to be charged based on the piping length, recover the refrigerant using the refrigerant recovery device, then achieve proper quantity of refrigerant.
E4 F3	The shutoff valves in the outdoor unit remain closed.	Open the shutoff valve on both the gas side and liquid side.
	The operation mode on the remote controller was changed before the check run.	Set the operating mode on all indoor unit remote controllers to “cooling”.
	The refrigerant is insufficient.	<ul style="list-style-type: none"> • Check whether additional refrigerant charge has been finished correctly. • Calculate again the required quantity of refrigerant to be charged based on the piping length, then charge additionally proper quantity of refrigerant.
F6	The refrigerant is overcharged.	Calculate again the required quantity of refrigerant to be charged based on the piping length, recover the refrigerant using the refrigerant recovery device, then achieve proper quantity of refrigerant.
U3	The check operation is not performed.	Perform the check operation.
U4	The power is not supplied to the outdoor unit.	Connect correctly the power cable of the outdoor unit.
UA	Improper type of indoor units are connected.	Check the type of indoor units currently connected. If they are not proper, replace them with proper ones.

UF	The shutoff valves in the outdoor unit remain closed.	Open the shutoff valve on both the gas side and liquid side.
	The piping and wiring of the specified indoor unit are not connected correctly to the outdoor unit.	Confirm that the piping and wiring of the specified indoor unit are connected correctly to the outdoor unit.
	The operation mode on the remote controller was changed before the check run.	Set the operating mode on all indoor unit remote controllers to "cooling".
UH	The unit-to-unit wirings are not connected correctly.	Connect correctly the unit-to-unit wirings to the F1 and F2(TO IN/D UNIT) terminals on the PC board (A1P) in the outdoor unit.

1.1.4 Confirmation on Normal Operation

- Conduct normal unit operation after the check operation has been completed.
(When outdoor air temperature is 30°CDB or higher, the unit can not be operated with heating mode. See the installation manual attached.)
- Confirm that the indoor/outdoor units can be operated normally.
(When an abnormal noise due to liquid compression by the compressor can be heard, stop the unit immediately, and turn on the crankcase heater to heat up it sufficiently, then start operation again.)
- Operate indoor unit one by one to check that the corresponding outdoor unit operates.
- Confirm that the indoor unit discharges cold air (or warm air).
- Operate the air direction control button and flow rate control button to check the function of the devices.

1.2 Operation When Power is Turned On

1.2.1 When Turning On Power First Time

The unit cannot be run for up to 12 minutes to automatically set the master power and address (indoor-outdoor address, etc.).

Status

Outdoor unit

Test lamp H2P Blinks

Can also be set during operation described above.

Indoor unit

If ON button is pushed during operation described above, the "UH" malfunction indicator blinks. (Returns to normal when automatic setting is complete.)

1.2.2 When Turning On Power the Second Time and Subsequent

Tap the RESET(BS5) button on the outdoor unit PC board. Operation becomes possible for about 2 minutes. If you do not push the RESET button, the unit cannot be run for up to 10 minutes to automatically set master power.

Status

Outdoor unit

Test lamp H2P Blinks

Can also be set during operation described above.

Indoor unit

If ON button is pushed during operation described above, the operation lamp lights but the compressor does not operate. (Returns to normal when automatic setting is complete.)

1.2.3 When an Indoor Unit or Outdoor Unit Has Been Added, or Indoor or Outdoor Unit PC Board Has Been Changed

Be sure to push and hold the RESET button for 5 seconds. If not, the addition cannot be recognized. In this case, the unit cannot be run for up to 12 minutes to automatically set the address (indoor-outdoor address, etc.).

Status

Outdoor unit

Test lamp H2P ON

Can also be set during operation described above.

Indoor unit

If ON button is pushed during operation described above, the "UH" or "U4" malfunction indicator blinks. (Returns to normal when automatic setting is complete.)

2. Outdoor Unit PC Board Layout

Outdoor unit PC board

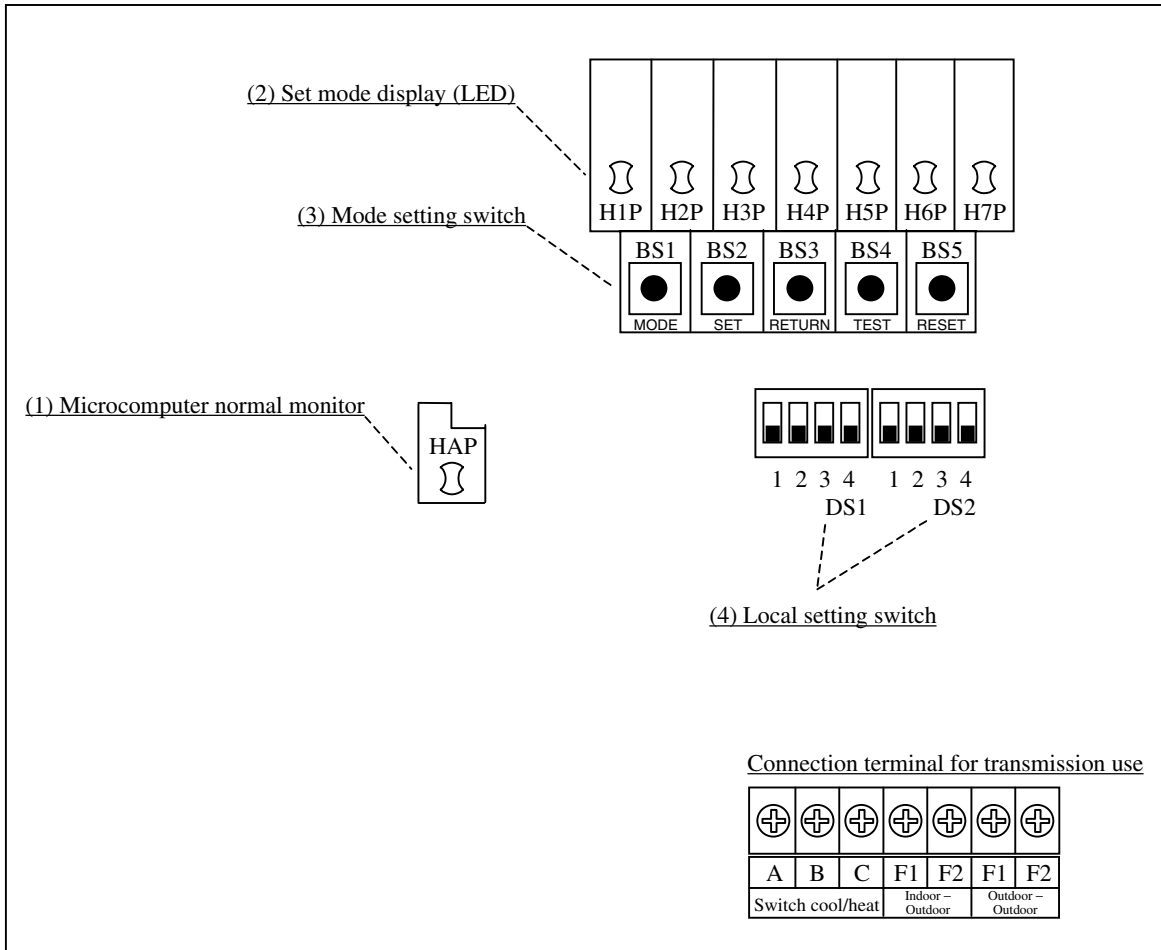

(V3171)

- (1) Microcomputer normal monitor (LED Green)
This monitor blinks while in normal operation, and turns on or off when a malfunction occurs.
- (2) Set mode display (LED Orange)
LEDs display mode according to the setting.
- (3) Mode setting switch
Used to change mode.
- (4) Local setting switch
Used to make local settings.

3. Field Setting

3.1 Field Setting from Remote Controller

Individual function of indoor unit can be changed from the remote controller. At the time of installation or after service inspection / repair, make the local setting in accordance with the following description.

Wrong setting may cause malfunction.





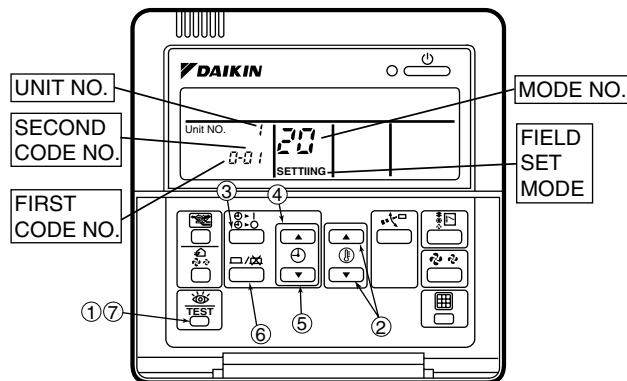

(When optional accessory is mounted on the indoor unit, setting for the indoor unit may be required to change. Refer to information in the option handbook.)

3.1.1 Wired Remote Controller <BRC1C71>

If optional accessories are mounted on the indoor unit, the indoor unit setting may have to be changed. Refer to the instruction manual for each optional accessory.



2P068938

1. When in the normal mode, press the “” button for a minimum of four seconds, and the FIELD SET MODE is entered.
2. Select the desired MODE NO. with the “” button (②).
3. During group control, when setting by each indoor unit (mode No. 20, 21 and 23 have been selected), push the “” button (③) and select the INDOOR UNIT NO to be set. (This operation is unnecessary when setting by group.)
4. Push the “” upper button (④) and select FIRST CODE NO.
5. Push the “” lower button (⑤) and select the SECOND CODE NO.
6. Push the “” button (⑥) once and the present settings are SET.
7. Push the “” button (⑦) for about one second to return to the NORMAL MODE.

(Example)





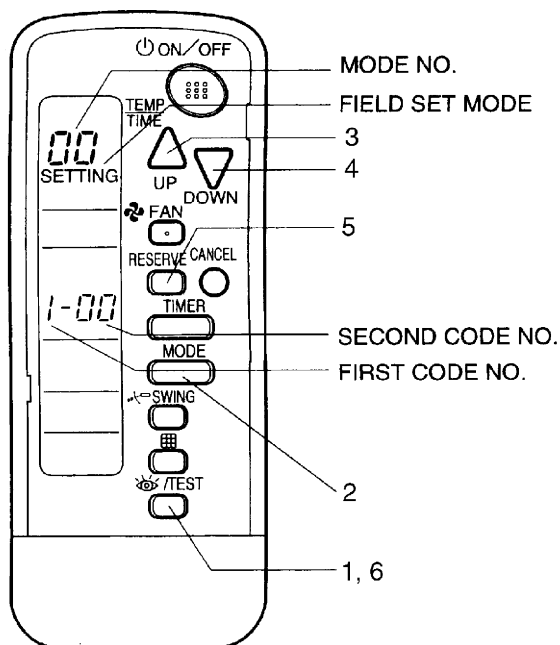

If during group setting and the time to clean air filter is set to FILTER CONTAMINATION, HEAVY, SET MODE NO. to “10” FIRST CODE NO. to “0,” and SECOND CODE NO. to “02.”

3.1.2 Wireless Remote Controller - Indoor Unit

BRC7C812
BRC4C82
BRC7E818
BRC7E83



(V2770)

1. When in the normal mode, push the  button for 4 seconds or more, and operation then enters the “field set mode.”
2. Select the desired “mode No.” with the  button.
3. Pushing the  button, select the first code No.
4. Pushing the  button, select the second code No.
5. Push the timer  button and check the settings.
6. Push the  button to return to the normal mode.

(Example)

When setting the filter sign time to “Filter Dirtiness-High” in all group unit setting, set the Mode No. to “10”, Mode setting No. to “0” and setting position No. to “02”.

3.1.3 Simplified Remote Controller BRC2A71

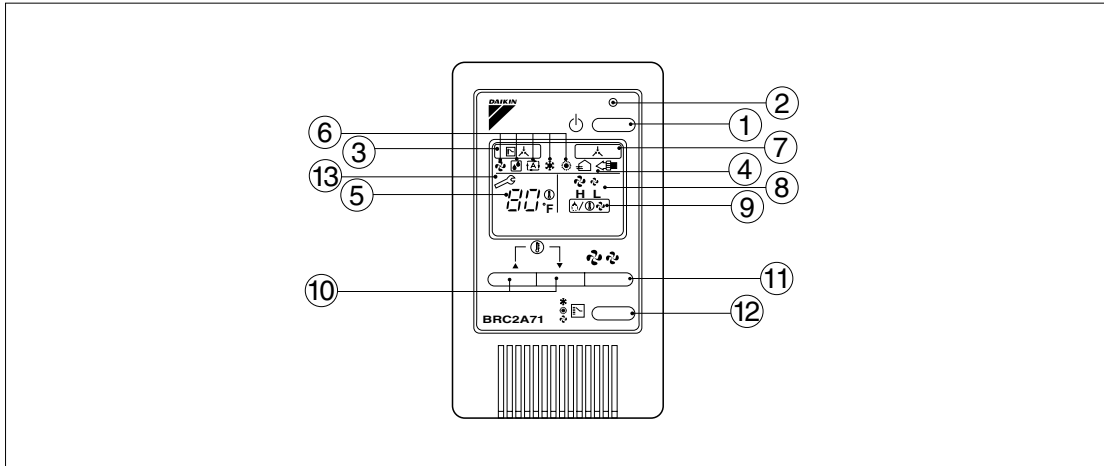

REMOTE CONTROLLER: NAME AND FUNCTION OF EACH SWITCH AND DISPLAY

①	ON/OFF BUTTON	⑦	DISPLAY “ [A] ” (UNDER CENTRALIZED CONTROL)
	Press the button and the system will start. Press the button again and the system will stop.		When this display shows, the system is UNDER CENTRALIZED CONTROL. (This is not a standard specification)
②	OPERATION LAMP (RED)	⑧	DISPLAY “ H L ” (FAN SPEED)
	The lamp lights up during operation. Blinks in case of stop due to malfunction.		This display shows the fan speed: HIGH or LOW.
③	DISPLAY “ [A] ” (CHANGEOVER UNDER CONTROL)	⑨	DISPLAY “ [A/①] ” (DEFROST / HOT START)
	It is impossible to changeover heating/cooling with the remote controller when it shows this display. (As for details, see “SETTING OF MASTER REMOTE CONTROLLER” in the installation manual attached to the indoor unit.)		Indicates that defrost or hot start (during which the fan is stopped till the temperature of air supply rises enough at the start of a heating operation) is in progress.
④	DISPLAY “ [A] ” (VENTILATION/AIR CLEANING)	⑩	TEMPERATURE SETTING BUTTON
	This display shows that the total heat exchanger and the air cleaning unit are in operation. (These are optional accessories).		Use this button for SETTING TEMPERATURE of the thermostat. ▲ ; Each press raises the set temperature by 1°F. ▼ ; Each press lowers the set temperature by 1°F. The variable temperature range is between 60°F and 90°F.
⑤	DISPLAY “ 80°F ” (SET TEMPERATURE)	⑪	FAN SPEED CONTROL BUTTON
	This display shows the set temperature. Only given during a cooling or heating operation.		Press this button to select the fan speed, HIGH or LOW, of your choice.
⑥	DISPLAY “ [A] ” “ [A] ” “ [A] ” “ [A] ” “ [A] ” (OPERATION MODE)	⑫	OPERATION MODE SELECTOR BUTTON
	This display shows current OPERATION MODE. “ [A] ” is not available with outdoor units specially designed for cooling only. “ [A] ” is reserved only for outdoor units capable of heat recovery.		Press this button to select OPERATION MODE.
⑬		⑬	DISPLAY “ [A] ” (MALFUNCTION)
			Indicates malfunction and blinks if the unit stops operating due to malfunction. (As for details, see “TROUBLE SHOOTING” in the operation manual attached to the outdoor unit.)

For the sake of explanation, all indications are shown in the figure above contrary to actual running situations.

3P146204

3.1.4 Setting Contents and Code No. – VRV Unit

Field Setting Contents and Code No.

Mode No. Note)2	FIRST CODE No.	Description of Setting	SECOND CODE NO. Note)3					
			01	02	03	04		
10(20)	0	Filter Contamination-Heavy/ Light (Setting for display time to clean air filter) (Sets display time to clean air filter to half when there is heavy filter contamination.)	Ultra-Long-Life Type	Approx. 10,000 hours	Approx. 5,000 hours	—	—	
		Long-Life Type	Light	Approx. 2,500 hours	Heavy			Approx. 1,250 hours
		Standard Type	Approx. 200 hours	Approx. 100 hours				
	1	Long-life filter type (Setting of filter sign indication time) (Change setting when Ultra-long-life filter is installed)	Long-Life Filter	Ultra-Long- Life Filter	—	—		
2	Thermostat Sensor in Remote Controller	Use	Not Use	—	—			
3	Display Time to Clean Air Filter Calculation (Set when filter sign is not to be displayed)	Display	Do not Display	—	—			
12(22)	0	Optional accessories output selection (field selection of output for adaptor for wiring)	Indoor Unit Turned ON by Thermostat	—	Operation Output	Malfunction Output		
	1	ON/OFF Input from Outside (Set when ON/OFF is to be controlled from outside.)	Forced Off	ON/OFF Control	External Protection Device Input	—		
	2	Thermostat Differential Changeover (Set when remote sensor is to be used.) FXFQ only	2°F	1°F	—	—		
	5	Power failure automatic reset (Auto Restart)	No equipped	Equipped	—	—		
13(23)	4	Field set air flow position setting	Draft Prevention	Standard	Ceiling Soiling Prevention	—		
	5	Field set fan speed selection (fan speed control by air discharge outlet for phase control)	Standard	Optional Accessory 1	Optional Accessory 2	—		

Notes:

- Settings are made simultaneously for the entire group, however, if you select the mode No. inside parentheses, you can also set by each individual unit. Setting changes however cannot be checked except in the individual mode for those in parentheses.
- The mode numbers inside parentheses cannot be used by wireless remote controllers, so they cannot be set individually. Setting changes also cannot be checked.
- Marked are factory set.
- Do not make settings other than those described above. Nothing is displayed for functions the indoor unit is not equipped with.
- “88” may be displayed to indicate the remote controller is resetting when returning to the normal mode.

3.1.5 Applicable Range of Field Setting

Mode No.	Setting Switch No.	Setting Contents	Ceiling mounted cassette type (Multi flow)	Ceiling mounted built-in type	Ceiling mounted duct type
			FXFQ	FXSQ	FXMQ
10 (20)	0	Filter sign	○	○	○
	1	Ultra long life filter sign	○	—	—
	2	Remote controller thermostat sensor	○	○	○
12 (22)	3	Set fan speed when thermostat OFF	○	○	○
13 (23)	0	Air flow adjustment Ceiling height	○	—	—
	1	Air flow direction	○	—	—
	3	Air flow direction adjustment (Down flow operation)	—	—	—
	4	Air flow direction adjustment range	○	—	—
	5	Field set fan speed selection	—	—	—

Mode No.	Setting Switch No.	Setting Contents	Ceiling suspended type	Wall mounted type	Floor standing type	Concealed Floor standing type
			FXHQ	FXAQ	FXLQ	FXNQ
10 (20)	0	Filter sign	○	○	○	○
	1	Ultra long life filter sign	—	—	—	—
	2	Remote controller thermostat sensor	○	○	○	○
12 (22)	3	Set fan speed when thermostat OFF	○	○	○	○
13 (23)	0	Air flow adjustment Ceiling height	○	—	—	—
	1	Air flow direction	—	—	—	—
	3	Air flow direction adjustment (Down flow operation)	—	—	—	—
	4	Air flow direction adjustment range	—	—	—	—
	5	Field set fan speed selection	—	—	—	—

3.1.6 Detailed Explanation of Setting Modes

Filter Sign Setting

If switching the filter sign ON time, set as given in the table below.

Set Time

Filter Specs. Setting	Mode No.	Setting Switch No.	Setting Position No.	Lighting interval of the filter sign (hours)		
				Standard	Long Life	Ultra Long Life Filter
Contamination Light	10(20)	0	01	200 hrs.	2,500 hrs.	10,000 hrs.
Contamination Heavy			02	100 hrs.	1,250 hrs.	5,000 hrs.

Fan Speed Changeover When Thermostat is OFF

By setting to "Set Fan Speed," you can switch the fan speed to the set fan speed when the heating thermostat is OFF.

* Since there is concern about draft if using "fan speed up when thermostat is OFF," you should take the setup location into consideration.

On warming, the priority is given to this over "airflow OFFSW on thermostat off".

© This is used to correspond with the improvement of the electrical collection capability.

Setting Table

Mode No.	First Code No.	Second Code No.	Setting
12(22)	3	01	LL Fan Speed
		02	Set Fan Speed

Auto Restart after Power Failure Reset

For the air conditioners with no setting for the function (same as factory setting), the units will be left in the stop condition when the power supply is reset automatically after power failure reset or the main power supply is turned on again after once turned off. However, for the air conditioners with the setting, the units may start automatically after power failure reset or the main power supply turned on again (return to the same operation condition as that of before power failure).

For the above reasons, when the unit is set enabling to utilize "Auto restart function after power failure reset", utmost care should be paid for the occurrence of the following situation.



- Caution**
- 1. The air conditioner starts operation suddenly after power failure reset or the main power supply turned on again. Consequently, the user might be surprised (with question for the reason why).**
 - 2. In the service work, for example, turning off the main power switch during the unit is in operation, and turning on the switch again after the work is completed start the unit operation (the fan rotates).**

Setting of Air Flow Direction Adjustment Range

Make the following air flow direction setting according to the respective purpose.

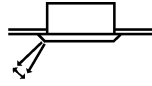

(S2537)

Setting Table

Mode No.	First Code No.	Second Code No.	Setting
13 (23)	4	01	Upward (Draft prevention)
		02	Standard
		03	Downward (Ceiling soiling prevention)

3.1.7 Centralized Control Group No. Setting

BRC1C Type



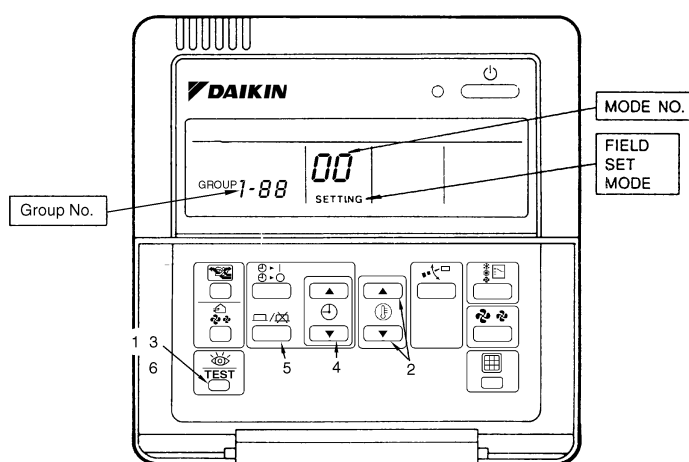



- If carrying out centralized control by central remote controller or unified ON/OFF controller, group No. must be set for each group individually by remote controller.
 - Group No. setting by remote controller for centralized control
1. If the inspection/test button is pushed for 4 seconds or more when in the normal mode, operation enters the “field set mode.”
 2. Using the temperature control buttons, set the mode No. to “00.”
 3. Push the inspection/test button to inspect the group No. display.
 4. Using the programming time button, set the group No. for each group. (Group No. rises in the order of 1-00, 1-01, ...1-15, 2-00 ...4-15, etc. The unified ON/OFF controller however displays only the range of group numbers selected by the switch for setting each address.)
 5. Push the timer ON/OFF button and enter the selected group No.
 6. Push the inspection/test button and return to the normal mode.



(S1095)

* If the address has to be set individually for each unit for power consumption counting, etc., set the mode No. to “30.”

BRC7C Type
BRC4C Type
BRC7E Type

- Group No. setting by wireless remote controller for centralized control
- 1. When in the normal mode, push  button for 4 seconds or more, and operation then enters the "field set mode."
- 2. Set mode No. "00" with  button.
- 3. Set the group No. for each group with   button (advance/backward).
- 4. Enter the selected group numbers by pushing  button.
- 5. Push  button and return to the normal mode.

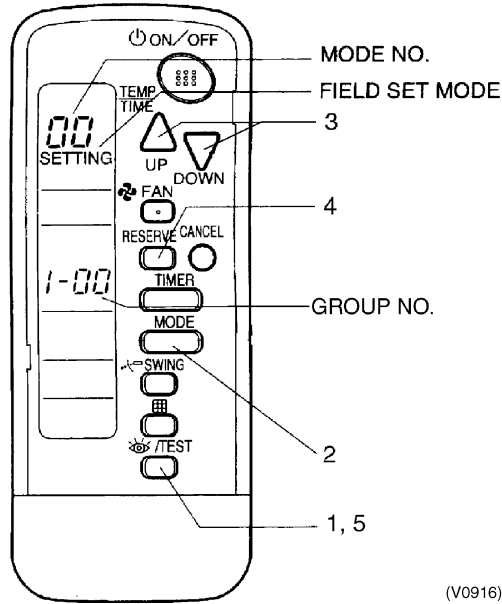

Group No. Setting Example

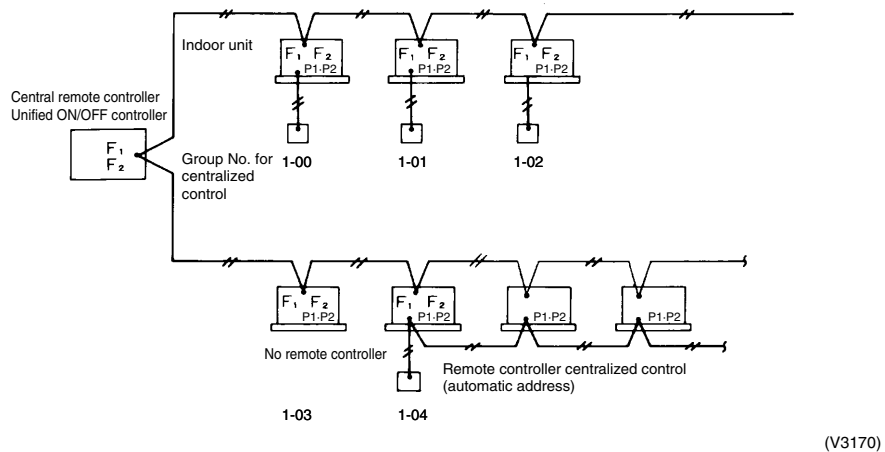

Caution

When turning the power supply on, the unit may often not accept any operation while "88" is displaying after all indications were displayed once for about 1 minute on the liquid crystal display. This is not an operative fault.

3.1.8 Setting of Operation Control Mode from Remote Controller (Local Setting)

The operation control mode is compatible with a variety of controls and operations by limiting the functions of the operation remote controller. Furthermore, operations such as remote controller ON/OFF can be limited in accordance with the combination conditions. (Refer to information in the table below.)

Centralized controller is normally available for operations. (Except when centralized monitor is connected)

3.1.9 Contents of Control Modes

Twenty modes consisting of combinations of the following five operation modes with temperature and operation mode setting by remote controller can be set and displayed by operation modes 0 through 19.

- ◆ ON/OFF control impossible by remote controller
Used when you want to turn on/off by central remote controller only.
(Cannot be turned on/off by remote controller.)
- ◆ OFF control only possible by remote controller
Used when you want to turn on by central remote controller only, and off by remote controller only.
- ◆ Centralized
Used when you want to turn on by central remote controller only, and turn on/off freely by remote controller during set time.
- ◆ Individual
Used when you want to turn on/off by both central remote controller and remote controller.
- ◆ Timer operation possible by remote controller
Used when you want to turn on/off by remote controller during set time and you do not want to start operation by central remote controller when time of system start is programmed.

How to Select Operation Mode

Whether operation by remote controller will be possible or not for turning on/off, controlling temperature or setting operation mode is selected and decided by the operation mode given on the right edge of the table below.

Example

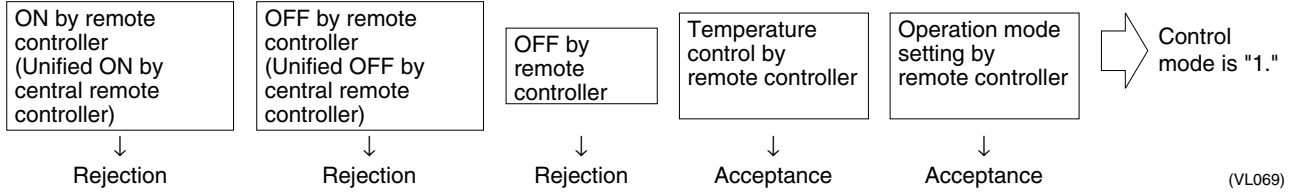

Control mode	Control by remote controller					Control mode		
	Operation		OFF	Temperature control	Operation mode setting			
	Unified operation, individual operation by central remote controller, or operation controlled by timer	Unified OFF, individual stop by central remote controller, or timer stop						
ON/OFF control impossible by remote controller	Rejection (Example)	Rejection (Example)	Rejection (Example)	Rejection	Acceptance	0		
OFF control only possible by remote controller				Acceptance	Acceptance	Acceptance (Example)	Rejection	10
						Acceptance (Example)	Acceptance (Example)	11
Centralized	Acceptance	Acceptance	Acceptance	Rejection	Acceptance	2		
Individual				Acceptance	Acceptance	Acceptance	Rejection	12
						Acceptance	Acceptance	3
Timer operation possible by remote controller	Acceptance (During timer at ON position only)	Rejection (During timer at OFF position)	Acceptance	Rejection	Acceptance	4		
				Acceptance	Rejection	14		
Timer operation possible by remote controller	Acceptance (During timer at ON position only)	Rejection (During timer at OFF position)	Acceptance	Acceptance	Acceptance	5		
				Acceptance	Rejection	15		
Timer operation possible by remote controller	Acceptance (During timer at ON position only)	Rejection (During timer at OFF position)	Acceptance	Rejection	Acceptance	6		
				Acceptance	Rejection	16		
Timer operation possible by remote controller	Acceptance (During timer at ON position only)	Rejection (During timer at OFF position)	Acceptance	Acceptance	Acceptance	7 *1		
				Acceptance	Rejection	17		
Timer operation possible by remote controller	Acceptance (During timer at ON position only)	Rejection (During timer at OFF position)	Acceptance	Rejection	Acceptance	8		
				Acceptance	Rejection	18		
Timer operation possible by remote controller	Acceptance (During timer at ON position only)	Rejection (During timer at OFF position)	Acceptance	Acceptance	Acceptance	9		
				Acceptance	Rejection	19		

Do not select "timer operation possible by remote controller" if not using a remote controller. Operation by timer is impossible in this case.

*1. Factory setting

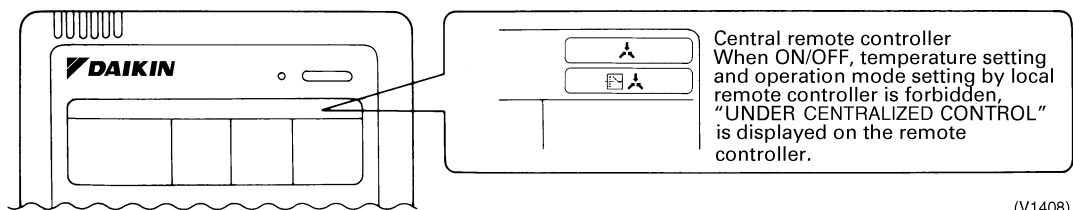

3.2 Field Setting from Outdoor Unit

3.2.1 Setting by dip switches

The following field settings are made by dip switches on PC board.

Dipswitch		Setting item	Description
No.	Setting		
DS1-1	ON	Cool / Heat change over setting	Used to set cool / heat change over setting by remote controller equipped with outdoor unit.
	OFF (Factory set)		
DS1-2 ~DS1-4	ON	Not used	Do not change the factory settings.
	OFF (Factory set)		
DS2-1 ~4	ON	Not used	Do not change the factory settings.
	OFF (Factory set)		



Caution

DIP switch Setting after changing the main P.C.Board(A1P) to spare parts P.C.B.

When you change the main P.C.Board(A1P) to spare parts P.C.B., please carry out the following setting.

The spare parts P.C.B. is different from the P.C.B. on factory shipment above in a way of setting. When you exchange to the spare parts P.C.B., make sure that you change setting referring the following table.



DIP Switch Detail

DS No.	Item	Contents		
DS1-1	Cool/Heat change over setting	ON	The Cool/Heat change over setting is carried out by COOL/HEAT changeover remote controller fitted to outdoor unit.	
		OFF	The Cool/Heat change over setting is not carried out by COOL/HEAT changeover remote controller fitted to outdoor unit.	
DS1-2	Cooling only/Heat-pump setting	ON	Cooling only	
		OFF	Heat-pump	
DS1-3 DS1-4	Not used	Do not change the factory settings.		
DS2-1	HP setting (Horse power)	The following setting is performed according to capability of the outdoor unit.		
DS2-2		DS2-1	RXYMQ36MVJU	RXYMQ48MVJU
DS2-3		DS2-2	ON	OFF
		DS2-3	OFF	ON
DS2-4		DS2-3	OFF	OFF
	DS2-4	OFF	OFF	

■ **Setting by pushbutton switches**

The following settings are made by pushbutton switches on PC board.

	H1P	H2P	H3P	H4P	H5P	H6P	H7P
LED display	●	●	○	●	●	●	●

(Factory setting)

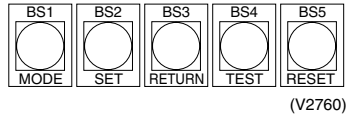

There are the following three setting modes.

① **Setting mode 1 (H1P off)**

Initial status (when normal) : Also indicates during “abnormal”.

② **Setting mode 2 (H1P on)**

Used to modify the operating status and to set program addresses, etc. Usually used in servicing the system.

③ **Monitor mode (H1P blinks)**

Used to check the program made in Setting mode 2.

■ **Mode changing procedure**

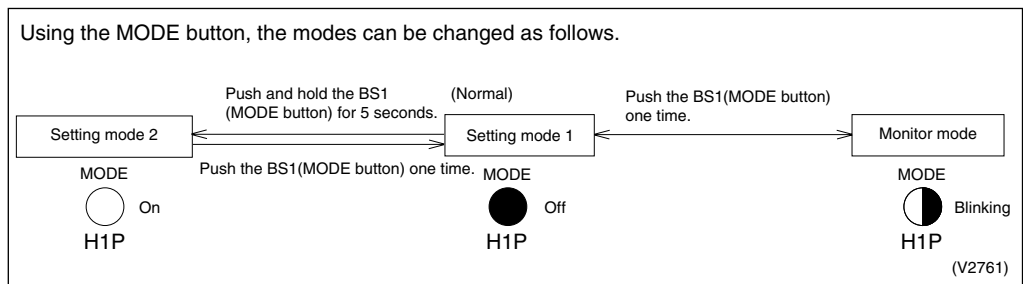

■ **Mode changing procedure**

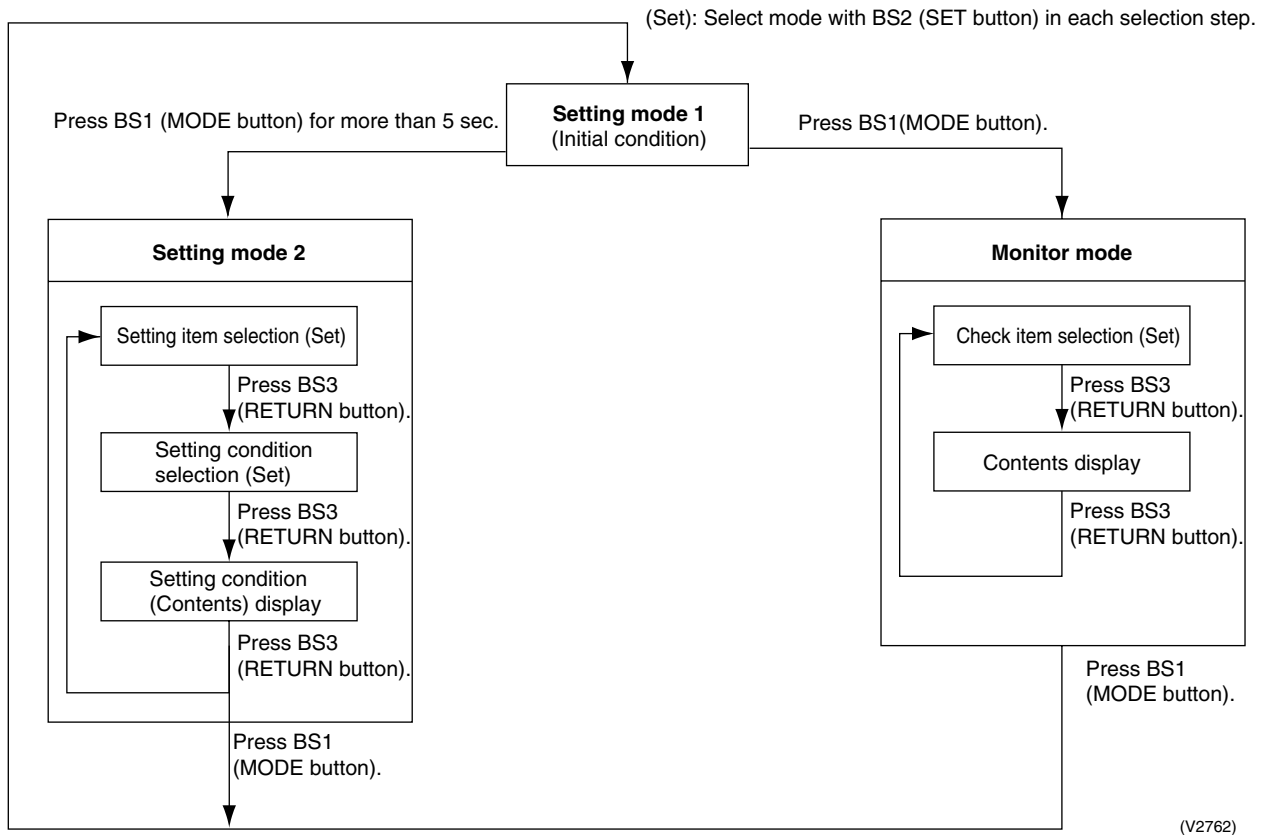

a. “Setting mode 1”

“Normally, “Setting mode 1” is set.
In case of other status, push MODE
button (BS1) one time and set to
“Setting mode 1”.



* The current state is displayed.

Display for malfunction/preparing/test-run

Setting (displaying) item	LED display example						
	H1P	H2P	H3P	H4P	H5P	H6P	H7P
Normal	●	●	○	●	●	●	●
Malfunction	●	○	○	●	●	●	●
Preparing/Test-run	●	◐	○	●	●	●	●

○ : ON ● : OFF ◐ : Blink

b. "Setting mode 2"

Push and hold the MODE button (BS1) for 5 seconds and set to "Setting mode 2".

<Selection of setting items>

Push the SET button (BS2) and set the LED display to a setting item shown in the table on the right.
↓
Push the RETURN button (BS3) and decide the item. (The present setting condition is blinked.)

<Selection of setting conditions>

Push the SET button (BS2) and set to the setting condition you want.
↓
Push the RETURN button (BS3) and decide the condition.

Push the RETURN button (BS3) and set to the initial status of "Setting mode 2".

No.	Setting item	Description
5	Indoor unit forced fan H	Allows forced operation of indoor unit fan while unit is stopped. (H tap)
6	Indoor unit forced operation	Allows forced operation of indoor unit.
8	Te setting	Target evaporation temperature for cooling
9	Tc setting	Target condensation temperature for heating
10	Defrost changeover setting	Changes the temperature condition for defrost and sets to quick defrost or slow defrost.
21	Refrigerant recovery / vacuuming mode setting	Sets to refrigerant recovery / vacuuming mode.
22	Night-time low noise setting	Sets automatic nighttime low noise operation in a simple way. The operating time is based on "Starting set" and "Ending set".
26	Night-time low noise operation start setting	Sets starting time of nighttime low noise operation. (Night-time low noise setting is also required.)
27	Night-time low noise operation end setting	Sets ending time of nighttime low noise operation. (Night-time low noise setting is also required.)
29	Capacity precedence setting	If the capacity control is required, the low noise control is automatically released by this setting during carrying out low noise operation and nighttime low noise operation.
30	Demand setting 1	Changes target value of power consumption when demand control 1 is input.
32	Normal demand setting	Normally enables demand control 1 without external input. (Effective to prevent a problem that circuit breaker of small capacity is shut down due to large load.

* If you become unsure of how to proceed, push the MODE button (BS1) and return to setting mode 1.

(V2764)

○ : ON ● : OFF ◐ : Blink

No.	Setting item display								Setting condition display		
	Setting item	MODE H1P	TEST H2P	C/H selection			Low noise H6P	Demand H7P			
				IND H3P	Master H4P	Slave H5P					
										* Factory set	
5	Indoor forced fan H	○	●	●	●	○	●	○	Normal operation	○ ● ● ● ● ● ● ○ *	
									Indoor forced fan H	○ ● ● ● ● ● ○ ●	
6	Indoor forced operation	○	●	●	●	○	○	●	Normal operation	○ ● ● ● ● ● ● ○ *	
									Indoor forced operation	○ ● ● ● ● ● ○ ●	
8	Te setting	○	●	●	○	●	●	●	High	○ ● ● ● ○ ● ●	
									Normal	○ ● ● ● ● ● ○ ● *	
									Low	○ ● ● ● ● ● ○	
9	Tc setting	○	●	●	○	●	●	○	High	○ ● ● ● ○ ● ●	
									Normal	○ ● ● ● ● ● ○ ● *	
									Low	○ ● ● ● ● ● ○	
10	Defrost changeover setting	○	●	●	○	●	○	●	Quick defrost	○ ● ● ● ○ ● ●	
									Normal	○ ● ● ● ● ● ○ ● *	
									Slow defrost	○ ● ● ● ● ● ○	
21	Refrigerant recovery / vacuuming mode setting	○	●	○	●	○	●	○	Refrigerant recovery: OFF	○ ● ● ● ● ● ○ *	
									Refrigerant recovery: ON	○ ● ● ● ● ● ○ ●	
22	Night-time low noise setting	○	●	○	●	○	○	●	OFF	○ ● ● ● ● ● ● ● *	
									Level 1	○ ● ● ● ● ● ● ○	
									Level 2	○ ● ● ● ● ● ○ ●	
									Level 3	○ ● ● ● ● ● ○ ○	
26	Night-time low noise operation start setting	○	●	○	○	●	○	●	About 20:00	○ ● ● ● ● ● ○	
									About 22:00	○ ● ● ● ● ● ○ ● *	
									About 24:00	○ ● ● ● ○ ● ●	
27	Night-time low noise operation end setting	○	●	○	○	●	○	○	About 6:00	○ ● ● ● ● ● ○	
									About 7:00	○ ● ● ● ● ● ○ ●	
									About 8:00	○ ● ● ● ○ ● ● *	
29	Capacity precedence setting	○	●	○	○	○	●	○	OFF	○ ● ● ● ● ● ○ *	
									ON	○ ● ● ● ● ● ○ ●	
30	Demand setting 1	○	●	○	○	○	○	●	60 % demand	○ ● ● ● ● ● ○	
									70 % demand	○ ● ● ● ● ● ○ ● *	
									80 % demand	○ ● ● ● ○ ● ●	
32	Normal demand setting	○	○	●	●	●	●	●	OFF	○ ● ● ● ● ● ○ *	
									ON	○ ● ● ● ● ● ○ ●	

○ : ON ● : OFF ◐ : Blink

c. Monitor mode

To enter the monitor mode, push the MODE button (BS1) when in "Setting mode 1".

<Selection of setting item>

Push the SET button (BS2) and set the LED display to a setting item.

<Confirmation on setting contents>

Push the RETURN button (BS3) to display different data of set items.

Push the RETURN button (BS3) and switches to the initial status of "Monitor mode".

No.	Setting item	LED display							Data display
		H1P	H2P	H3P	H4P	H5P	H6P	H7P	
0	Various settings	◐	●	●	●	●	●	●	See below
5	Number of connected indoor units	◐	●	●	●	○	●	○	Lower 6 digits
14	Contents of malfunction (the latest)	◐	●	●	○	○	○	●	Malfunction code table
15	Contents of malfunction (1 cycle before)	○	●	●	○	○	○	○	
16	Contents of malfunction (2 cycle before)	○	●	○	●	●	●	●	
20	Contents of retry (the latest)	○	●	○	●	○	●	●	
21	Contents of retry (1 cycle before)	○	●	○	●	○	●	○	
22	Contents of retry (2 cycle before)	○	●	○	●	○	○	●	

Setting item 0 Display contents of "Various settings"

Defrost select setting	Short	◐	●	●	●	○	●	●
	Medium	◐	●	●	●	◐	●	●
	Long	◐	●	●	●	●	●	●
Te setting	H	◐	●	●	●	●	○	●
	M	◐	●	●	●	●	◐	●
	L	◐	●	●	●	●	●	●
Tc setting	H	◐	●	●	●	●	●	○
	M	◐	●	●	●	●	●	◐
	L	◐	●	●	●	●	●	●

* Push the MODE button (BS1) and returns to "Setting mode 1".

(V2765)

Push the SET button and match with the LEDs No. 1 - 15, push the RETURN button, and enter the data for each setting.

★ Data such as addresses and number of units is expressed as binary numbers; the two ways of expressing are as follows:

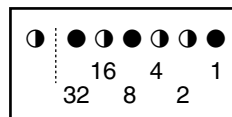

The No. 5 cool/heat unified address is expressed as a binary number consisting of the lower 6 digits. (0 - 63)

In ① the address is 000110 (binary number), which translates to 4 + 2 = 6 (base 10 number). In other words, the address is 6.

3.3 Detail of Setting Mode

3.3.1 Cool / Heat Mode Switching

There are the following 2 cool/heat switching modes.

- ① Set cool/heat separately for each outdoor unit system by indoor unit remote controller.
- ② Set cool/heat separately for each outdoor unit system by cool/heat switching remote controller.

① Set Cool / Heat Separately for Each Outdoor System by Indoor Unit Remote Controller

- ◆ It does not matter whether or not there is outdoor - outdoor unit wiring.
- ◆ Set outdoor unit PC board DS1-1 to "indoor" (factory set).
- ◆ Set cool/heat switching to "individual" for "Setting mode 1" (factory set).

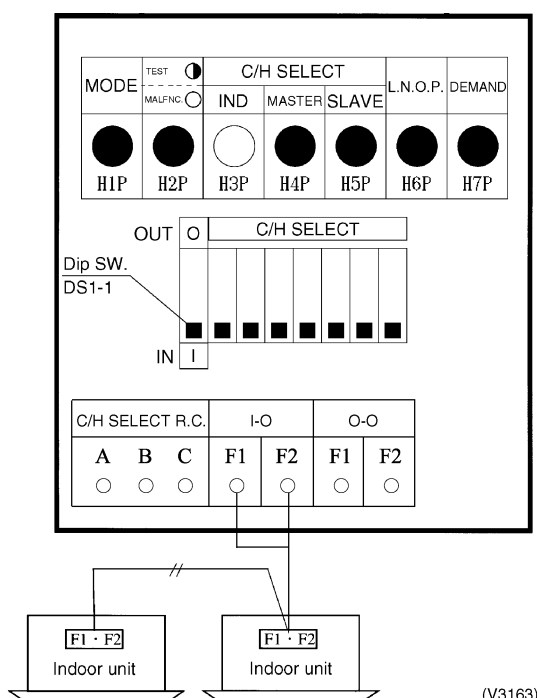

② **Set Cool / Heat Separately for Each Outdoor Unit System by Cool / Heat Switching Remote Controller**

- ◆ It does not matter whether or not there is outdoor - outdoor unit wiring.
- ◆ Set outdoor unit PC board DS1-1 to "outdoor" (factory set).
- ◆ Set cool/heat switching to "individual" for "Setting mode 1" (factory set).

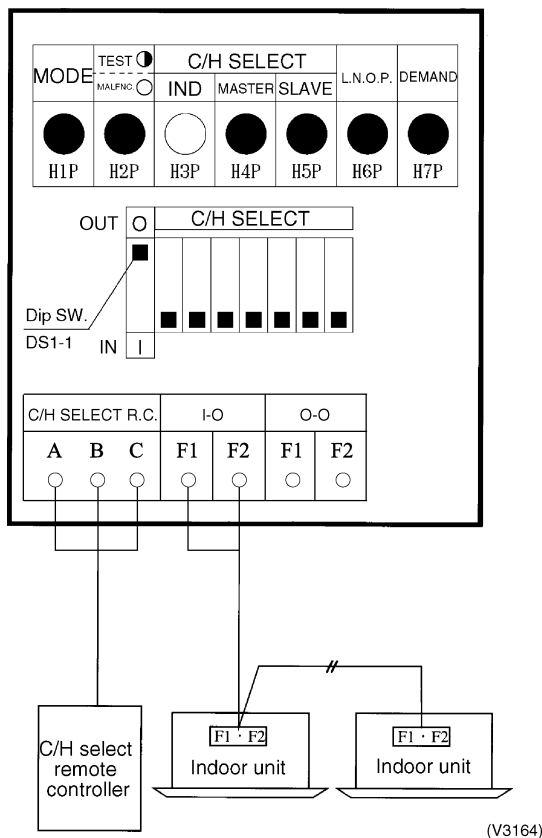

3.3.2 Setting of Low Noise Operation and Demand Operation

Setting of Low Noise Operation

By connecting the external contact input to the low noise input of the outdoor unit external control adaptor (optional), you can lower operating noise by 2-3 dB.

A. When the low noise operation is carried out by external instructions (with the use of the external control adaptor for outdoor unit)

1. Set "External low noise / Demand YES/NO setting" to "External low noise / Demand YES". (Set by Setting Mode 2)
2. Set "External low noise level setting" on the outdoor unit PCB, as the need arises. (Lower noise operation can be carried out by "Mode 2" than by "Mode 1", and by "Mode 3" than by "Mode 2".)
3. Set "Capacity precedence setting" on the outdoor unit PCB, as the need arises. (If set to "ON", when air conditioning load gets higher, the low noise instructions are neglected to switch to normal operation.) (Set by Setting Mode 2)

B. When the low noise operation is carried out automatically at night (The external control adaptor for outdoor unit is not required)

1. Set "Night-time low noise setting" on the outdoor unit PCB. (Set by Setting Mode 2) (Lower noise operation can be carried out by "Mode 2" than by "Mode 1", and by "Mode 3" than by "Mode 2".)
2. Set "Night-time low noise start setting" on the outdoor unit PCB, as the need arises. (Set by Setting Mode 2) (Since the time is presumed in accordance with the outdoor temperature, the starting time is a target only.)
3. Set "Night-time low noise end setting" on the outdoor unit PCB, as the need arises. (Set by Setting Mode 2) (Since the time is presumed in accordance with the outdoor temperature, the ending time is a target only.)
4. Set "Capacity precedence setting" on the outdoor unit PCB, as the need arises. (Set by Setting Mode 2) (If set to "ON", when air conditioning load gets higher, the status is switched to normal operation even at night.)

Image of operation in the case of A

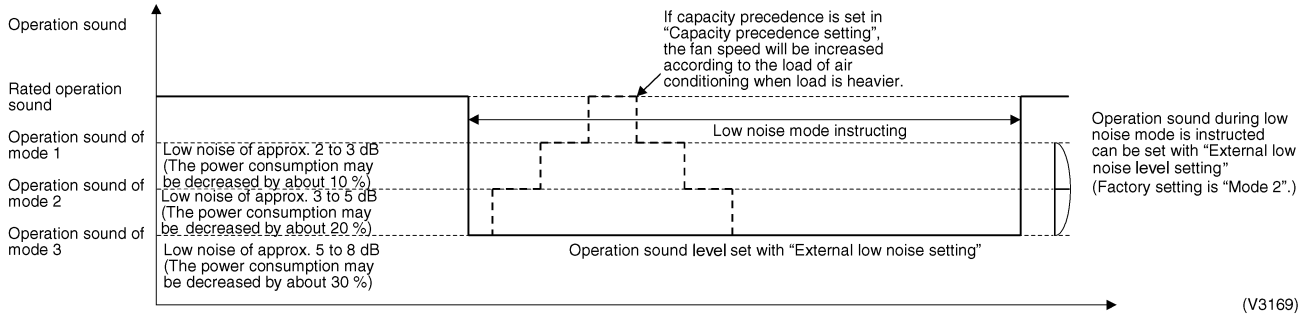

(V3169)

Image of operation in the case of B

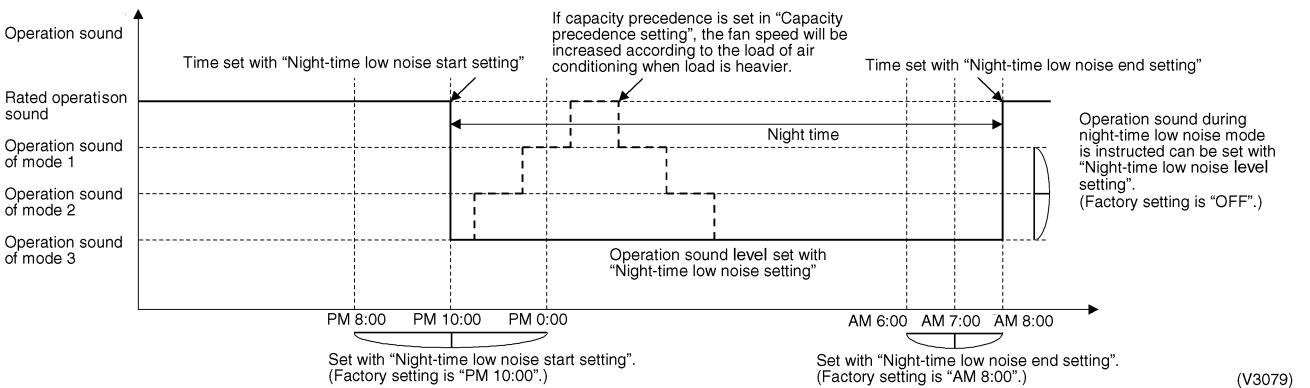

(V3079)

Image of operation in the case of A and B

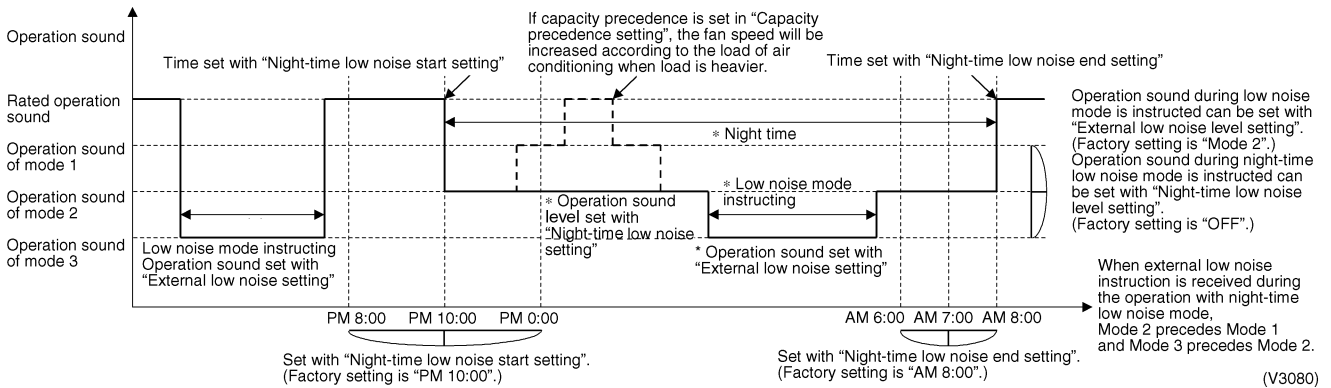

(V3080)

Setting of Demand Operation

By connecting the external contact input to the demand input of the outdoor unit external control adaptor (optional), the power consumption of unit operation can be saved suppressing the compressor operating condition.

[Demand 1 setting]

Setting	Standard for upper limit of power consumption
Demand 1 setting 1	Approx. 60%
Demand 1 setting 2 (factory setting)	Approx. 70%
Demand 1 setting 3	Approx. 80%

[Demand 2 setting]

Setting	Standard for upper limit of power consumption
Demand 2 setting 2 (factory setting)	Approx. 40%

★Other protection control functions have precedence over the above operation.

A. When the demand operation is carried out by external instructions (with the use of the external control adaptor for outdoor unit).

1. Set the "External low noise/Demand YES/NO setting" switch on the outdoor unit PCB to the "External low noise/Demand YES".
(Set by Setting Mode 2)
2. Set the "Demand 1 level setting" on the outdoor unit PCB, as the need arises.
(During the demand level 1 instruction, the power consumption can be saved to 80 %, 70 % or 60 % of the rated value respectively.)

B. When the continuous demand operation is carried out. (Use of the external control adaptor for outdoor unit is not required.)

1. Set the "Continuous demand setting" on the outdoor unit PCB.
2. If the "Continuous demand setting" is set to the "Continuous demand 1 fixing", set the "Demand 1 setting" on the outdoor unit PCB, as the need arises.
(During the continuous demand level 1 operation, the power consumption can be saved to 80 %, 70 % or 60 % of the rated value respectively.)

Image of operation in the case of A

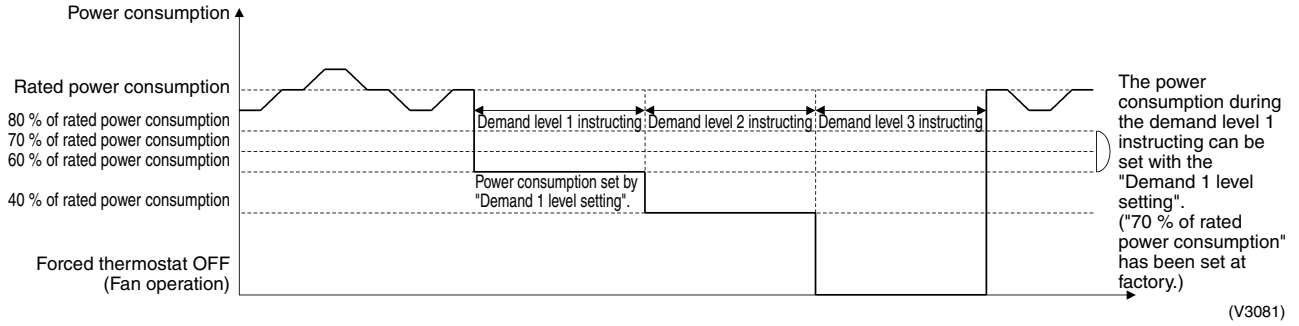

Image of operation in the case of B

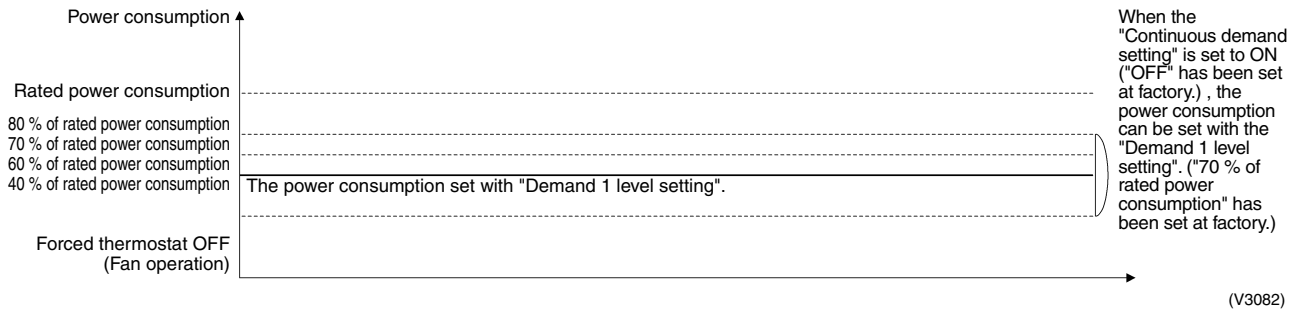
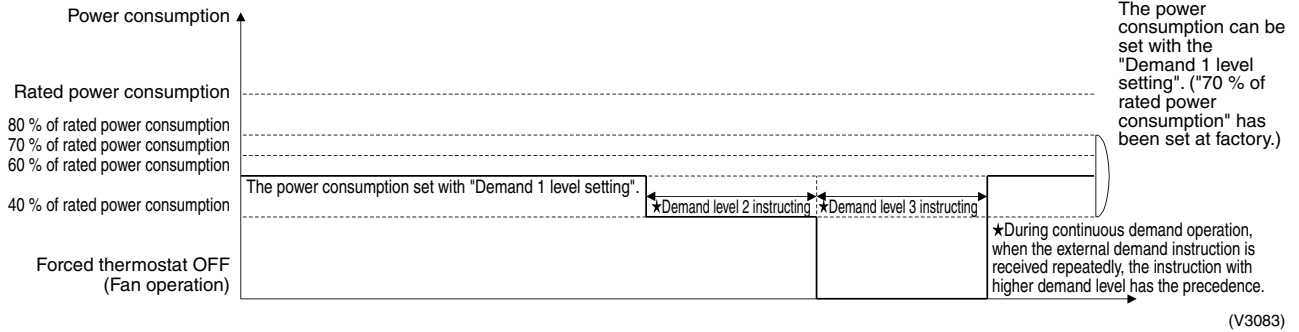

Image of operation in the case of A and B



Detailed Setting Procedure of Low Noise Operation and Demand Control

1. Setting mode 1 (H1P off)

- ① In setting mode 2, push the BS1 (MODE button) one time. → Setting mode 2 is entered and H1P lights.
During the setting mode 1 is displayed, “In low noise operation” and “In demand control” are displayed.

2. Setting mode 2 (H1P on)

- ① In setting 1, push and hold the BS1 (MODE button) for more than 5 seconds. → Setting mode 2 is entered and H1P lights.
- ② Push the BS2 (SET button) several times and match the LED display with the Setting No. you want.
- ③ Push the BS3 (RETURN button) one time, and the present setting content is displayed.
→ Push the BS2 (SET button) several times and match the LED display with the setting content (as shown below) you want.
- ④ Push the BS3 (RETURN button) two times. → Returns to ①.
- ⑤ Push the BS1 (MODE button) one time. → Returns to the setting mode 1 and turns H1P off.

○: ON ●: OFF ◐: Blink

Setting No.	Setting contents	①							②							Setting contents	③							
		Setting No. indication							Setting No. indication								Setting contents indication (Initial setting)							
		H1P	H2P	H3P	H4P	H5P	H6P	H7P	H1P	H2P	H3P	H4P	H5P	H6P	H7P		H1P	H2P	H3P	H4P	H5P	H6P	H7P	
12	External low noise / Demand setting	○	●	●	●	●	●	●	○	●	●	○	○	●	●	NO (Factory set)	○	●	●	●	●	●	●	◐
															YES	○	●	●	●	●	●	◐	●	
22	Night-time low noise setting								○	●	○	●	○	○	●	OFF (Factory setting)	○	●	●	●	●	●	●	●
															Mode 1	○	●	●	●	●	●	●	◐	
															Mode 2	○	●	●	●	●	●	◐	●	
															Mode 3	○	●	●	●	●	●	◐	◐	
25	External low noise setting								○	●	○	○	●	●	○	Mode 1	○	●	●	●	●	●	●	◐
															Mode 2 (Factory setting)	○	●	●	●	●	●	◐	●	
															Mode 3	○	●	●	●	◐	●	●		
26	Night-time low noise start setting								○	●	○	○	●	○	●	PM 8:00	○	●	●	●	●	●	●	◐
															PM 10:00 (Factory setting)	○	●	●	●	●	●	◐	●	
															PM 0:00	○	●	●	●	◐	●	●		
27	Night-time low noise end setting								○	●	○	○	●	○	○	AM 6:00	○	●	●	●	●	●	●	◐
															AM 7:00	○	●	●	●	●	●	◐	●	
															AM 8:00 (Factory setting)	○	●	●	●	◐	●	●		
29	Capacity precedence setting								○	●	○	○	○	●	○	Low noise precedence (Factory setting)	○	●	●	●	●	●	●	◐
															Capacity precedence	○	●	●	●	●	●	◐	●	
30	Demand setting 1								○	●	○	○	○	○	●	60 % of rated power consumption	○	●	●	●	●	●	●	◐
															70 % of rated power consumption (Factory setting)	○	●	●	●	●	●	◐	●	
															80 % of rated power consumption	○	●	●	●	◐	●	●		
32	Continuous demand setting								○	●	●	●	●	●	●	OFF (Factory setting)	○	●	●	●	●	●	●	◐
															Continuous demand 1 fixed	○	●	●	●	●	◐	●		

Setting mode indication section

Setting No. indication section

Set contents indication section

3.3.3 Setting of Refrigerant Recovery Mode

When carrying out the refrigerant collection on site, fully open the respective expansion valve of indoor and outdoor units

Both the outdoor unit and the indoor unit are forbidden to operation.

[Operation procedure]

- ① In **setting mode 2** with units in stop mode, set “Refrigerant Recovery / Vacuuming mode” to ON. The respective expansion valve of indoor and outdoor units are fully opened. (H2P turns to display “TEST OPERATION” (blinks), “TEST OPERATION” and “UNDER CENTRALIZED CONTROL” are displayed on the remote controller, and the operation is prohibited.)
- ② Collect the refrigerant using a refrigerant recovery unit. (See the instruction attached to the refrigerant recovery unit for more detail.)
- ③ Press Mode button “BS1” once and reset “Setting Mode 2”.

3.3.4 Setting of Vacuuming Mode

In order to perform vacuuming operation at site, fully open the expansion valves of indoor and outdoor units to turn on some solenoid valves.

Both the outdoor unit and the indoor unit are forbidden to operation.

[Operating procedure]

- ① With **Setting Mode 2** while the unit stops, set “Refrigerant recovery / Vacuuming mode” to ON. The expansion valves of indoor and outdoor units fully open and some of solenoid valves open.
(H2P blinks to indicate the test operation, and the remote controller displays “TEST OPERATION” and “UNDER CENTRALIZED CONTROL”, thus prohibiting operation.)
After setting, do not cancel “Setting Mode 2” until completion of Vacuuming operation.
- ② Use the vacuum pump to perform vacuuming operation.
- ③ Press Mode button “BS1” once and reset “Setting Mode 2”.

3.3.5 Check Operation

To prevent any trouble in the period of installation at site, the system is provided with a test operation mode enabling check for incorrect wiring, stop valve left in closed, and judgment of piping length.

CHECK OPERATION FUNCTION

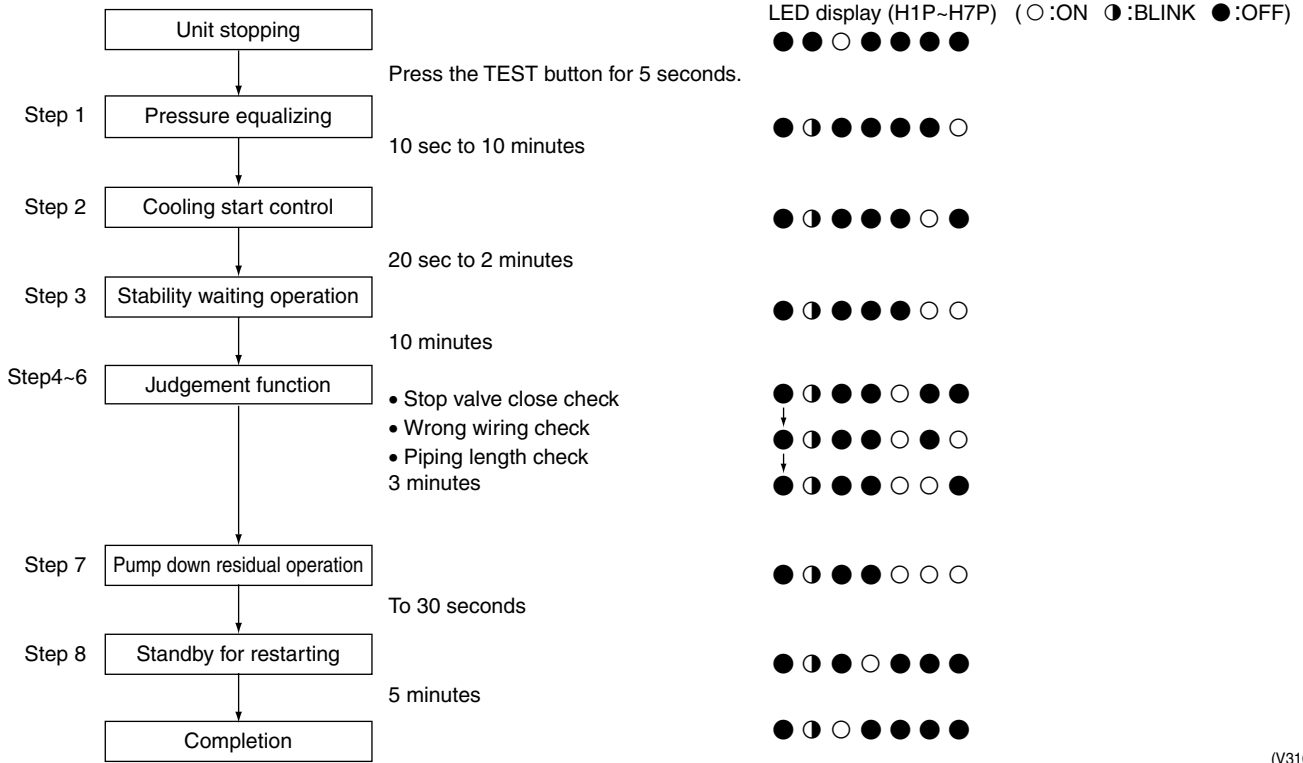

(V3165)

Part 7

Troubleshooting

1. Troubleshooting by Remote Controller	90
1.1 The INSPECTION / TEST Button	90
1.2 Self-Diagnosis by Wired Remote Controller.....	91
1.3 Self-Diagnosis by Wireless Remote Controller	92
1.4 Operation of the Remote Controller's Inspection / Test Operation Button	94
1.5 Remote Controller Service Mode	95
2. List of Malfunction Code	97
3. Malfunction Code Indication by Outdoor Unit PCB	100
4. Troubleshooting by Indication on the Remote Controller	102
4.1 "RD" Indoor Unit: Error of External Protection Device	102
4.2 "R1" Indoor Unit: PC Board Defect	103
4.3 "R3" Indoor Unit: Malfunction of Drain Level Control System (S1L).....	104
4.4 "R5" Indoor Unit: Fan Motor (M1F) Lock, Overload	106
4.5 "R7" Indoor Unit: Malfunction of Swing Flap Motor (MA).....	107
4.6 "R9" Indoor Unit: Malfunction of Moving Part of Electronic Expansion Valve (20E)	109
4.7 "RF" Indoor Unit: Drain Level above Limit	111
4.8 "RJ" Indoor Unit: Malfunction of Capacity Determination Device	112
4.9 "CY" Indoor Unit: Malfunction of Thermistor (R2T) for Heat Exchanger	113
4.10 "CS" Indoor Unit: Malfunction of Thermistor (R3T) for Gas Pipes	114
4.11 "CS" Indoor Unit: Malfunction of Thermistor (R1T) for Suction Air	115
4.12 "CR" Indoor Unit: Malfunction of Thermistor for Discharge Air	116
4.13 "CJ" Indoor Unit: Malfunction of Thermostat Sensor in Remote Controller	117
4.14 "E1" Outdoor Unit: PC Board Defect.....	118
4.15 "E3" Outdoor Unit: Actuation of High Pressure Switch.....	119
4.16 "E4" Outdoor Unit: Actuation of Low Pressure Switch	120
4.17 "E5" Outdoor Unit: Compressor Motor Lock.....	122
4.18 "E7" Outdoor Unit: Malfunction of Outdoor Unit Fan Motor	123
4.19 "E9" Outdoor Unit: Malfunction of Moving Part of Electronic Expansion Valve	125
4.20 "F3" Outdoor Unit: Abnormal Discharge Pipe Temperature	127
4.21 "H9" Outdoor Unit: Malfunction of Thermistor (R1T) for Outdoor Air	128
4.22 "J3" Outdoor Unit: Malfunction of Discharge Pipe Thermistor (R3T)....	129
4.23 "J5" Outdoor Unit: Malfunction of Thermistor (R2T) for Suction Pipe...	130
4.24 "J6" Outdoor Unit: Malfunction of Thermistor (R4T) for Outdoor Unit Heat Exchanger.....	131
4.25 "J9" Outdoor Unit: Malfunction of Subcooling Heat Exchanger Gas Pipe Thermistor (R5T).....	132
4.26 "JR" Outdoor Unit: Malfunction of High Pressure Sensor	133

4.27	“JL” Outdoor Unit: Malfunction of Low Pressure Sensor	135
4.28	“LY” Outdoor Unit: Malfunction of Inverter Radiating Fin Temperature Rise	136
4.29	“L5” Outdoor Unit: Inverter Compressor Abnormal	137
4.30	“LB” Outdoor Unit: Inverter Current Abnormal.....	138
4.31	“L9” Outdoor Unit: Inverter Start up Error	140
4.32	“LC” Outdoor Unit: Malfunction of Transmission between Inverter and Control PC Board	141
4.33	“PY” Outdoor Unit: Malfunction of Inverter Radiating Fin Temperature Rise Sensor	143
4.34	“PJ” Outdoor Unit: Faulty Combination of Inverter and Fan Driver	144
4.35	“UD” Outdoor Unit: Low Pressure Drop Due to Refrigerant Shortage or Electronic Expansion Valve Failure.....	145
4.36	“U2” Outdoor Unit: Power Supply Insufficient or Instantaneous Failure	146
4.37	“U3” Outdoor Unit: Check Operation not Executed	148
4.38	“U4” Malfunction of Transmission between Indoor Units and Outdoor Units	149
4.39	“U5” Indoor Unit: Malfunction of Transmission between Remote Controller and Indoor Unit	151
4.40	“UB” Indoor Unit: Malfunction of Transmission between Main and Sub Remote Controllers	152
4.41	“U9” Indoor Unit: Malfunction of Transmission between Indoor Units and Outdoor Units in the Same System	153
4.42	“UR” Improper Combination of Indoor Units and Outdoor Units, Indoor Units and Remote Controller	155
4.43	“UC” Address Duplication of Central Remote Controller	156
4.44	“UE” Malfunction of Transmission between Central Remote Controller and Indoor Unit	157
4.45	“UF” System not Set yet	159
4.46	“UH” Malfunction of System, Refrigerant System Address Undefined.....	160
5.	Troubleshooting by Indication on the Central Remote Controller	161
5.1	“UE” Malfunction of Transmission between Central Remote Controller and Indoor Unit	161
5.2	“M1” PC Board Defect	163
5.3	“M8” Malfunction of Transmission between Optional Controllers for Centralized Control	164
5.4	“M9” Improper Combination of Optional Controllers for Centralized Control	165
5.5	“MC” Address Duplication, Improper Setting	167
6.	Troubleshooting by Indication on the Unified ON/OFF Controller	168
6.1	Operation Lamp Blinks	168
6.2	Display “Under Centralized Control” Blinks (Repeats Single Blink)	170
6.3	Display “Under Centralized Control” Blinks (Repeats Double Blink)....	173
7.	Troubleshooting (OP: Schedule Timer)	174
7.1	“UE” Malfunction of Transmission between Central Remote Controller and Indoor Unit	174
7.2	“M1” PC Board Defect	176

7.3	“nB” Malfunction of Transmission between Optional Controllers for Centralized Control	177
7.4	“nR” Improper Combination of Optional Controllers for Centralized Control	178
7.5	“nC” Address Duplication, Improper Setting	180
8.	Check	181

1. Troubleshooting by Remote Controller

1.1 The INSPECTION / TEST Button

The following modes can be selected by using the  button on the remote control.

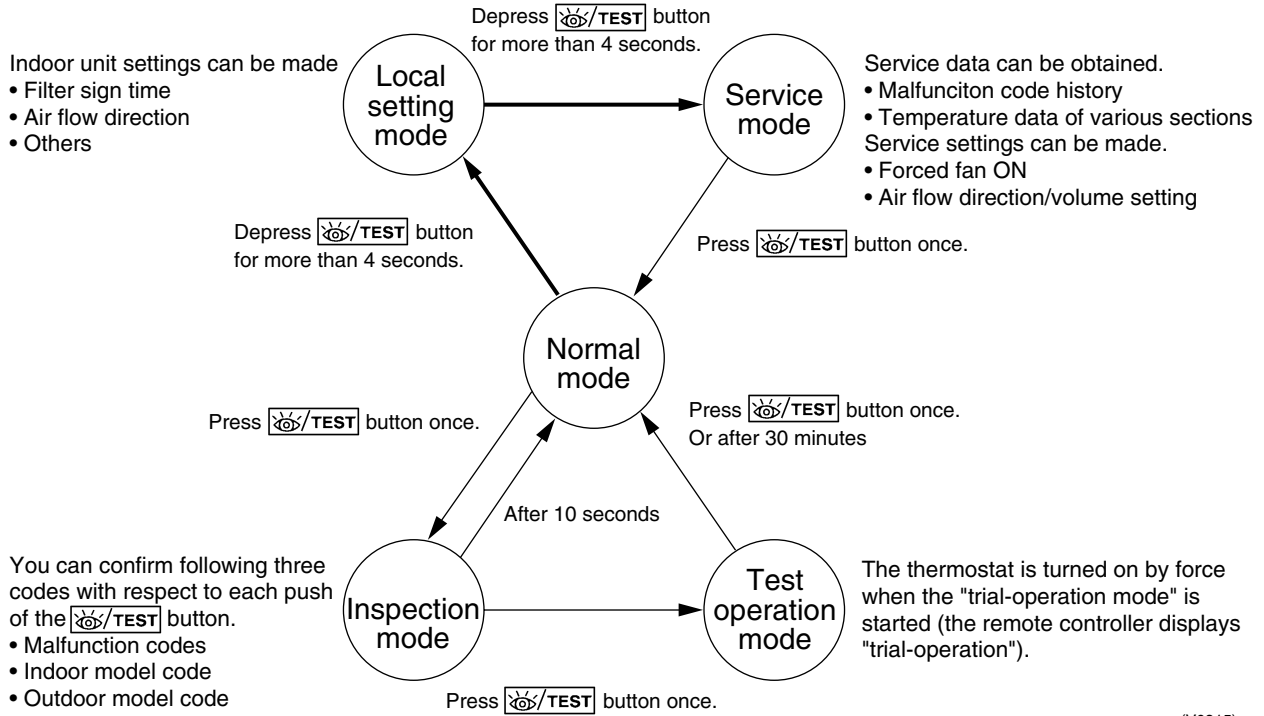

(V0815)

1.2 Self-Diagnosis by Wired Remote Controller

Explanation

If operation stops due to malfunction, the remote controller's operation LED blinks, and malfunction code is displayed. (Even if stop operation is carried out, malfunction contents are displayed when the inspection mode is entered.) The malfunction code enables you to tell what kind of malfunction caused operation to stop.

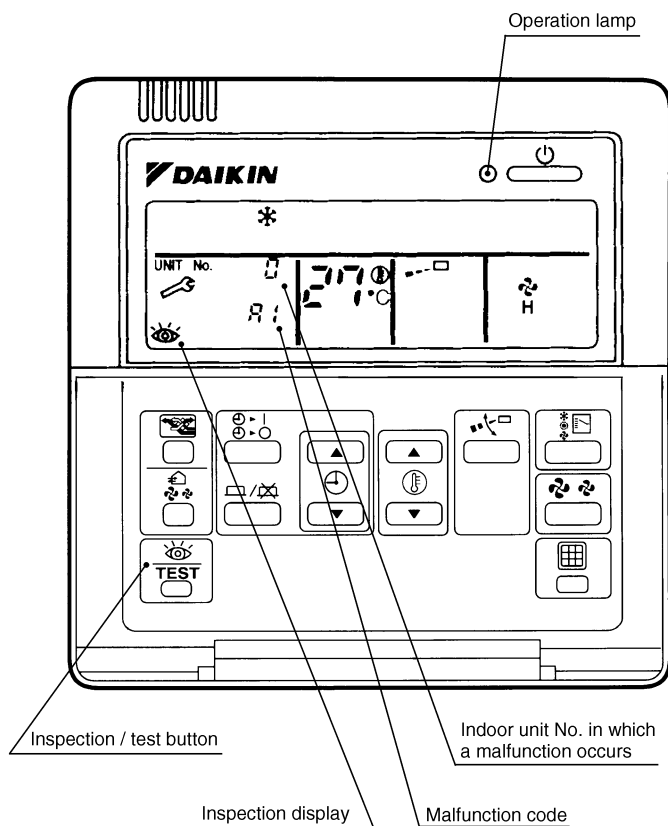

(S2001)

1.3 Self-Diagnosis by Wireless Remote Controller

In the Case of BRC7C Type BRC4C Type BRC7E Type

You can confirm the error code as following.

If equipment stops due to a malfunction, the operation indicating LED on the light reception section flashes.

The malfunction code can be determined by following the procedure described below. (The malfunction code is displayed when an operation error has occurred. In normal condition, the malfunction code of the last problem is displayed.)

1. Press the INSPECTION/TEST button to select "Inspection."
The equipment enters the inspection mode. The "Unit" indication lights and the Unit No. display shows flashing "0" indication.
 2. Set the Unit No.
Press the UP or DOWN button and change the Unit No. display until the buzzer (*1) is generated from the indoor unit.
*1 Number of beeps
3 short beeps : Conduct all of the following operations.
1 short beep : Conduct steps 3 and 4.
Continue the operation in step 4 until a buzzer remains ON. The continuous buzzer indicates that the malfunction code is confirmed.
Continuous beep : No abnormality.
 3. Press the MODE selector button.
The left "0" (upper digit) indication of the malfunction code flashes.
 4. Malfunction code upper digit diagnosis
Press the UP or DOWN button and change the malfunction code upper digit until the malfunction code matching buzzer (*2) is generated.
- The upper digit of the code changes as shown below when the UP and DOWN buttons are pressed.

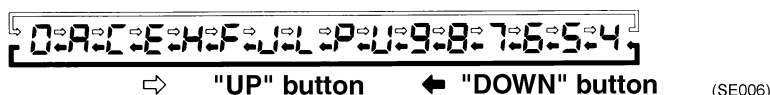

*2 Number of beeps

Continuous beep : Both upper and lower digits matched. (Malfunction code confirmed)

2 short beeps : Upper digit matched.

1 short beep : Lower digit matched.

5. Press the MODE selector button.
The right "0" (lower digit) indication of the malfunction code flashes.
6. Malfunction code lower digit diagnosis
Press the UP or DOWN button and change the malfunction code lower digit until the continuous malfunction code matching buzzer (*2) is generated.

- The lower digit of the code changes as shown below when the UP and DOWN buttons are pressed.

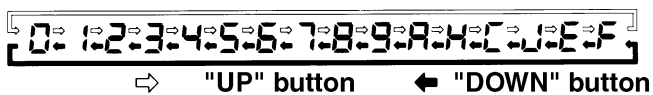

(SE007)

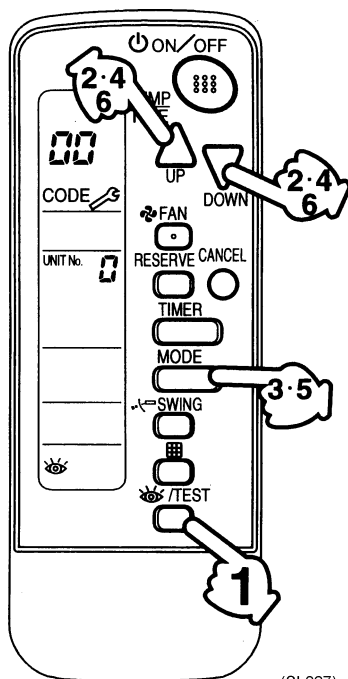

(SL027)

1.4 Operation of the Remote Controller's Inspection / Test Operation Button

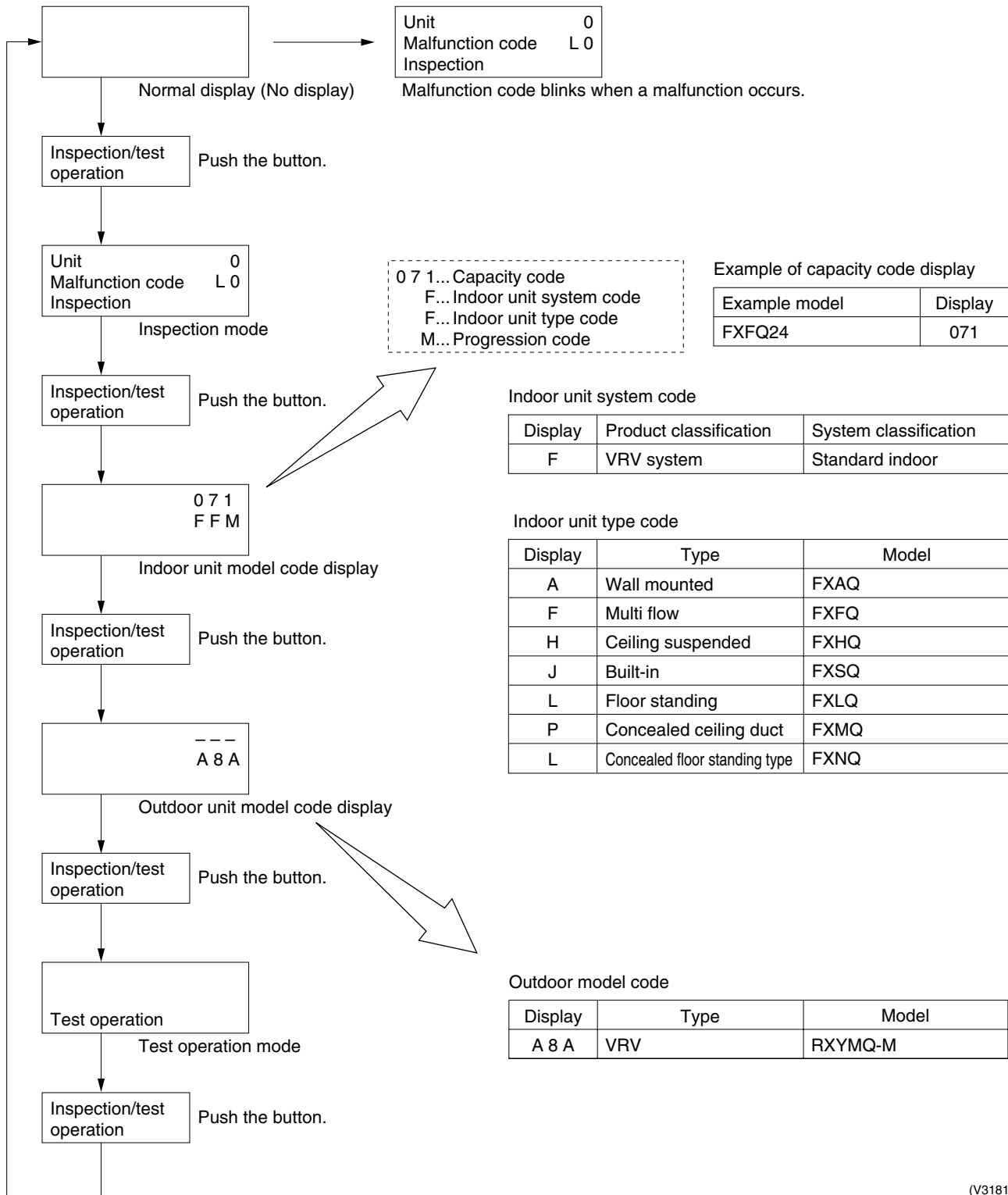

(V3181)

1.5 Remote Controller Service Mode

You can take “service data” and make a “service setting” in the service mode, with operating the  button on the remote controller.

How to Enter the Service Mode

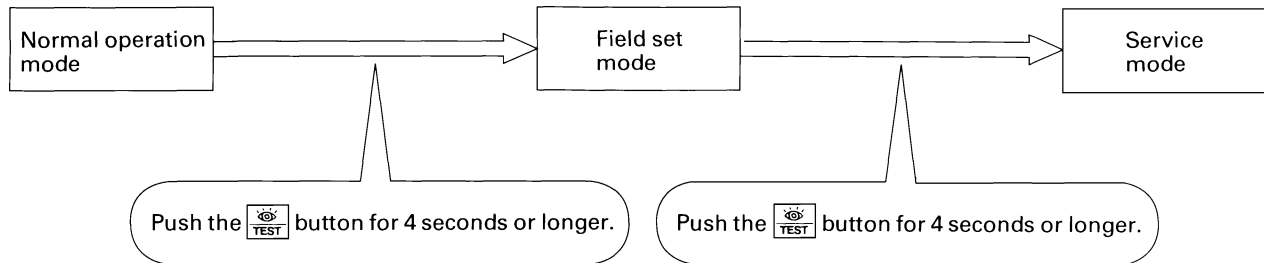



(VF020)

Service Mode Operation Method

1. Select the mode No.

Set the desired mode No. with the  button.
(For wireless remote controller, Mode 43 only can be set.)

2. Select the unit No. (For group control only)

Select the indoor unit No. to be set with the time mode . (For wireless remote controller,  button.)

3. Make the settings required for each mode.

In case of Mode 44, 45, push  button to be able to change setting before setting work.
(LCD “code” blinks.)









For details, refer to the table in next page.

4. Define the setting contents. (Modes 44, 45)

Define by pushing the timer  button.
After defining, LCD “code” changes blinking to ON.

5. Return to the normal operation mode.

Push the  button one time.

Mode No	Function	Contents and operation method	Remote controller display example
40	Malfunction hysteresis display	<p>Display malfunction hysteresis.</p> <p>The history No. can be changed with the  button.</p>	<p>Unit 1 Malfunction code 40</p> <p>2-U4 Malfunction code</p> <p>History No: 1 - 9 1: Latest</p> <p>(VE007)</p>
41	Display of sensor and address data	<p>Display various types of data.</p> <p>Select the data to be displayed with the  button.</p> <p>Sensor data 0: Thermostat sensor in remote controller. 1: Suction 2: Liquid pipe 3: Gas pipe</p> <p>Address data 4: Indoor unit address 5: Outdoor unit address 6: BS unit address 7: Zone control address 8: Cool/heat group address 9: Demand / low noise address</p>	<p>Sensor data display</p> <p>Unit No. Sensor type</p> <p>1 1 2 7 41</p> <p>Temperature °C</p> <p>Address display</p> <p>Unit No. Address type</p> <p>1 8 1 41</p> <p>Address</p> <p>(VE008)</p>
43	Forced fan ON	<p>Manually turn the fan ON by each unit. (When you want to search for the unit No.)</p> <p>By selecting the unit No. with the  button, you can turn the fan of each indoor unit on (forced ON) individually.</p>	<p>Unit 1 43</p> <p>(VE009)</p>
44	Individual setting	<p>Set the fan speed and air flow direction by each unit</p> <p>Select the unit No. with the time mode  button.</p> <p>Set the fan speed with the  button.</p> <p>Set the air flow direction with the  button.</p>	<p>Unit 1 Code 44</p> <p>1 3</p> <p>Fan speed 1: Low 3: High</p> <p>Air flow direction P0 - P4</p> <p>(VE010)</p>
45	Unit No. transfer	<p>Transfer unit No.</p> <p>Select the unit No. with the  button. Set the unit No. after transfer with the  button.</p>	<p>Present unit No.</p> <p>Unit 1 Code 45</p> <p>0 2 Unit No. after transfer</p> <p>(VE011)</p>

2. List of Malfunction Code

○: ON ●: OFF ◐: Blink

	Malfunction code	Operation lamp	Inspection display	Unit No.	Malfunction contents	Page Referred
Indoor Unit	A0	◐	◐	◐	Error of external protection device	102
	A1	◐	◐	◐	PC board defect, E ² PROM defect	103
	A3	◐	◐	◐	Malfunction of drain level control system (S1L)	104
	A6	◐	◐	◐	Fan motor (M1F) lock, overload	106
	A7	○	●	◐	Malfunction of swing flap motor (MA)	107
	A9	◐	◐	◐	Malfunction of moving part of electronic expansion valve (20E)	109
	AF	○	●	◐	Drain level above limit	111
	AJ	◐	◐	◐	Malfunction of capacity setting	112
	C4	◐	◐	◐	Malfunction of thermistor (R2T) for heat exchange (loose connection, disconnection, short circuit, failure)	113
	C5	◐	◐	◐	Malfunction of thermistor (R3T) for gas pipes (loose connection, disconnection, short circuit, failure)	114
	C9	◐	◐	◐	Malfunction of thermistor (R1T) for air inlet (loose connection, disconnection, short circuit, failure)	115
	CA	◐	◐	◐	Malfunction of thermistor for air outlet (loose connection, disconnection, short circuit, failure)	116
	CJ	○	○	○	Malfunction of thermostat sensor in remote controller	117

 The system operates for malfunction codes indicated in black squares, however, be sure to check and repair.

○: ON ●: OFF ◐: Blink

	Malfunction code	Operation lamp	Inspection display	Unit No.	Malfunction contents	Page Referred
Outdoor Unit	E1	◐	◐	◐	PC board defect, E ² PROM defect	118
	E3	◐	◐	◐	Actuation of high pressure switch	119
	E4	◐	◐	◐	Actuation of low pressure switch	120
	E5	◐	◐	◐	Compressor motor lock	122
	E6	◐	◐	◐	Standard compressor lock or over current	—
	E7	◐	◐	◐	Malfunction of outdoor unit fan motor	123
	E9	◐	◐	◐	Malfunction of moving part of electronic expansion valve (Y1E~3E)	125
	F3	◐	◐	◐	Abnormal discharge pipe temperature	127
	F6	◐	◐	◐	Refrigerant overcharged	—
	H3	○	●	◐	Malfunction of High pressure switch	—
	H4	◐	◐	◐	Actuation of Low pressure switch	—
	H7	◐	◐	◐	Abnormal outdoor fan motor signal	—
	H9	◐	◐	◐	Malfunction of thermistor (R1T) for outdoor air (loose connection, disconnection, short circuit, failure)	128
	J2	◐	◐	◐	Current sensor malfunction	—
	J3	◐	◐	◐	Malfunction of discharge pipe thermistor (R3T) (loose connection, disconnection, short circuit, failure)	129
	J5	◐	◐	◐	Malfunction of thermistor (R2T) for suction pipe (loose connection, disconnection, short circuit, failure)	130
	J6	◐	◐	◐	Malfunction of thermistor (R4T) for heat exchanger (loose connection, disconnection, short circuit, failure)	131
	J9	◐	◐	◐	Malfunction of subcooling heat exchanger gas pipe thermistor (R5T)	132
	JA	◐	◐	◐	Malfunction of high pressure sensor	133
	JC	◐	◐	◐	Malfunction of low pressure sensor	135
	L0	◐	◐	◐	Inverter system error	—
	L4	◐	◐	◐	Malfunction of inverter radiating fin temperature rise	136
	L5	◐	◐	◐	Inverter compressor abnormal	137
	L6	◐	◐	◐	Compressor motor coil grounding on short circuit	—
	L8	◐	◐	◐	Inverter current abnormal	138
	L9	◐	◐	◐	Inverter start up error	140
	LA	◐	◐	◐	Malfunction of power unit	—
LC	◐	◐	◐	Malfunction of transmission between inverter and control PC board	141	
P1	◐	◐	◐	Inverter over-ripple protection	—	
P4	◐	◐	◐	Malfunction of inverter radiating fin temperature rise sensor	143	
PJ	◐	◐	◐	Faulty combination of inverter and fan driver	144	

 The system operates for malfunction codes indicated in black squares, however, be sure to check and repair.

○: ON ●: OFF ◐: Blink

	Malfunction code	Operation lamp	Inspection display	Unit No.	Malfunction contents	Page Referred
System	U0	○	●	◐	Low pressure drop due to refrigerant shortage or electronic expansion valve failure	145
	U1	◐	◐	◐	Reverse phase / open phase	—
	U2	◐	◐	◐	Power supply insufficient or instantaneous failure	146
	U3	◐	◐	◐	Check operation not executed	148
	U4	◐	◐	◐	Malfunction of transmission between indoor units and outdoor units	149
	U5	◐	◐	◐	Malfunction of transmission between remote controller and indoor unit	151
	U5	●	○	●	Failure of remote controller PC board or setting during control by remote controller	—
	U7	◐	◐	◐	Malfunction of transmission between outdoor units	—
	U8	◐	◐	●	Malfunction of transmission between main and sub remote controllers (malfunction of sub remote controller)	152
	U9	◐	◐	◐	Malfunction of transmission between indoor unit and outdoor unit in the same system	153
	UA	◐	◐	◐	Improper combination of indoor and outdoor unit, indoor unit and remote controller	155
	UC	○	○	○	Address duplication of central remote controller	156
	UE	◐	◐	◐	Malfunction of transmission between central remote controller and indoor unit	157
	UF	◐	◐	◐	Refrigerant system not set, incompatible wiring / piping	159
UH	◐	◐	◐	Malfunction of system, refrigerant system address undefined	160	
Central remote Controller and Schedule Timer	UE	◐	◐	◐	Malfunction of transmission between central remote controller and indoor unit	161
	M1	○ or ●	◐	◐	Central remote controller PC board defect	163
	M8	○ or ●	◐	◐	Malfunction of transmission between optional controllers for centralized control	164
	MA	○ or ●	◐	◐	Improper combination of optional controllers for centralized control	165
	MC	○ or ●	◐	◐	Address duplication, improper setting	167

 The system operates for malfunction codes indicated in black squares, however, be sure to check and repair.

3. Malfunction Code Indication by Outdoor Unit PCB

<Monitor mode>

To enter the monitor mode, push the MODE button (BS1) when in "Setting mode 1".

<Selection of setting item>

Push the SET button (BS2) and set the LED display to a setting item.

<Confirmation of malfunction 1>

Push the RETURN button (BS3) once to display "First digit" of malfunction code.

<Confirmation of malfunction 2>

Push the SET button (BS2) once to display "Second digit" of malfunction code.

<Confirmation of malfunction 3>

Push the SET button (BS2) once to display "master or slave1 or slave2" and "malfunction location".

Push the RETURN button (BS3) and switches to the initial status of "Monitor mode".

Detail description on the right.

Contents of malfunction		Malfunction code
Abnormal discharge pressure	HPS activated	E3
Abnormal suction pressure	Abnormal Pe	E4
Compressor lock	Detection of INV compressor lock	E5
Over load, over current, abnormal lock of outdoor unit fan motor	Instantaneous over current of DC fan motor	E7
	Detection of DC fan motor lock	
Malfunction of electronic expansion valve	EV1	E9
	EV2	
Faulty sensor of outdoor air temperature	Faulty Ta sensor	H9
Abnormal discharge pipe temperature	Abnormal Td	F3
Faulty sensor of discharge pipe temperature	Faulty Tdi sensor	J3
Faulty sensor of suction pipe temperature	Faulty Ts sensor	J5
Faulty sensor of heat exchanger temperature	Faulty Tb sensor	J6
Faulty sensor of subcool heat exchanger temperature	Faulty Tsh sensor	J9
Faulty sensor of discharge pressure	Faulty Pc sensor	JA
Faulty sensor of suction pressure	Faulty Pe sensor	JC
DC output over current	Inverter instantaneous over current	L5
Electronic thermal switch	Electronic thermal switch 1	L8
	Electronic thermal switch 2	
	Out-of-step	
	Speed down after startup	
	Lightening detection	
Stall prevention (Limit time)	Stall prevention (Current increasing)	L9
	Stall prevention (Faulty startup)	
	Abnormal wave form in startup	
	Out-of-step	
Transmission error between inverter and outdoor unit	Inverter transmission error	LC
Open phase / Power supply imbalance	Imbalance of inverter power supply voltage	P1
Faulty temperature sensor inside switch box	Faulty thermistor of inverter box	P3
Faulty temperature sensor of inverter radiation fin	Faulty thermistor of inverter fin	P4
Incorrect combination of inverter and fan driver	Incorrect combination of inverter and fan driver	PJ
Gas shortage	Gas shortage alarm	U0
Abnormal power supply voltage	Insufficient inverter voltage	U2
	Inverter open phase (phase T)	
	Charging error of capacitor in inverter main circuit	
	Over voltage	
Abnormal SP-PAM	Over voltage	
	Over current/Over voltage (Hard detection)	
Abnormal latch circuitry		
No implementation of test-run		U3
Transmission error between indoor and outdoor unit	I/O transmission error	U4
Transmission error of other system	Indoor unit system malfunction in other system or other unit of own system	U9
Erroneous on-site setting	Abnormal connection with excessive number of indoor units	UA
	Conflict of refrigerant type in indoor units	
Faulty system function	Incorrect wiring (Auto address error)	UH
Transmission error in accessory devices, conflict in wiring and piping, no setting for system	Malfunction of multi level converter, abnormality in conflict check	UF

* Push the MODE button (BS1) and returns to "Setting mode 1".

○: ON ●: OFF ◐: Blink

Malfunction code	Confirmation of malfunction 1							Confirmation of malfunction 2							Confirmation of malfunction 3						
	H1P	H2P	H3P	H4P	H5P	H6P	H7P	H1P	H2P	H3P	H4P	H5P	H6P	H7P	H1P	H2P	H3P	H4P	H5P	H6P	H7P
E3	◐			●	●	◐	◐	◐			●	●	◐	◐	◐			●	●	●	●
E4								◐			●	◐	●	●	◐			●	●	●	●
E5								◐			●	◐	●	◐	◐			●	●	●	●
E7								◐			●	◐	◐	◐	◐			●	●	●	◐
E9								◐			◐	●	●	◐	◐			●	●	◐	●
H9	◐			●	◐	●	●	◐			◐	●	●	◐	◐			●	●	●	●
F3	◐			●	◐	●	◐	◐			●	●	◐	◐	◐			●	●	●	●
J3	◐			●	◐	◐	●	◐			●	●	◐	◐	◐			●	●	●	◐
J5								◐			●	◐	●	◐	◐			●	●	●	●
J6								◐			●	◐	●	◐	◐			●	●	●	●
J9								◐			◐	●	●	◐	◐			●	●	●	●
JA								◐			◐	●	◐	●	◐			●	●	●	●
JC								◐			◐	◐	●	●	◐			●	●	●	●
L5	◐			●	◐	◐	◐	◐			●	◐	●	◐	◐			●	●	●	●
L8								◐			◐	●	●	●	◐			●	●	●	●
L9								◐			◐	●	●	◐	◐			●	●	●	●
LC								◐			◐	◐	●	●	◐			●	●	●	●
P1	◐			◐	●	●	●	◐			●	●	●	◐	◐					●	●
P3								◐			●	◐	◐	◐	◐					●	●
P4								◐			●	◐	●	◐	◐					●	●
PJ								◐			◐	◐	●	◐	◐					●	●
U0	◐			◐	●	●	◐	◐			●	●	●	●	◐			●	●	●	●
U2								◐			●	●	◐	●	◐			●	●	●	●
U3								◐			●	●	◐	◐	◐			●	●	●	●
U4								◐			●	◐	●	●	◐			●	●	●	●
U9								◐			◐	●	●	●	◐			●	●	●	●
UA								◐			◐	●	◐	●	◐			●	●	●	●
UH								◐			◐	●	◐	◐	◐			●	●	●	●
UF								◐			◐	◐	◐	◐	◐			●	●	●	●

Malfunction code 1st digit display section

Malfunction code 2nd digit display section

Malfunction location

Master	●	●
Slave 1	●	◐
Slave 2	◐	●

(V3168)

4. Troubleshooting by Indication on the Remote Controller

4.1 "A0" Indoor Unit: Error of External Protection Device

Remote Controller Display	A0
Applicable Models	All indoor unit models
Method of Malfunction Detection	Detect open or short circuit between external input terminals in indoor unit.
Malfunction Decision Conditions	When an open circuit occurs between external input terminals with the remote controller set to "external ON/OFF terminal".
Supposed Causes	<ul style="list-style-type: none"> ■ Actuation of external protection device ■ Improper field set ■ Defect of indoor unit PC board

Troubleshooting



Caution

Be sure to turn off power switch before connect or disconnect connector, or parts damage may be occurred.

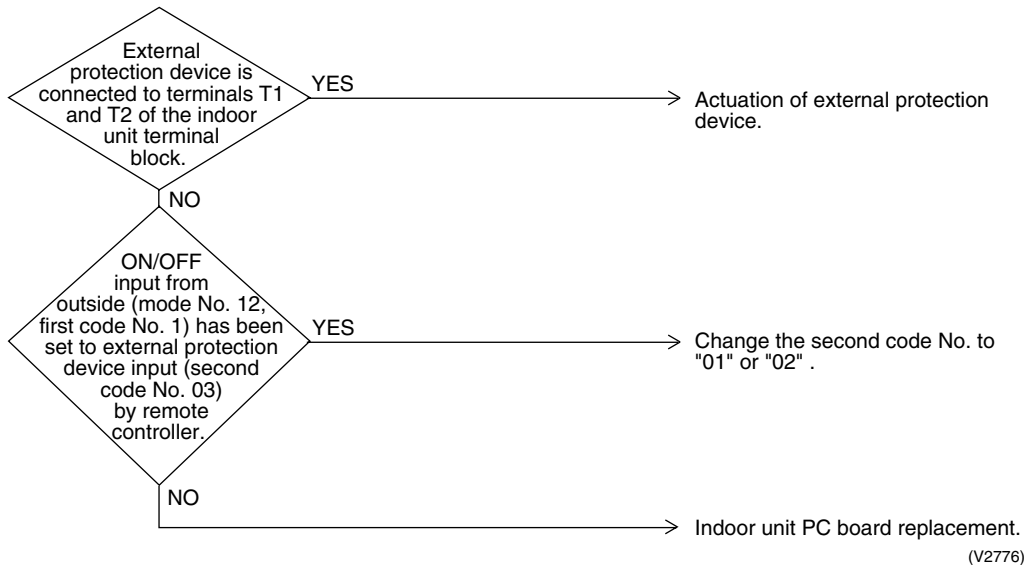

4.2 “A1” Indoor Unit: PC Board Defect

Remote
Controller
Display

A1

Applicable
Models

All indoor unit models

Method of
Malfunction
Detection

Check data from E²PROM.

Malfunction
Decision
Conditions

When data could not be correctly received from the E²PROM
E²PROM : Type of nonvolatile memory. Maintains memory contents even when the power supply is turned off.

Supposed
Causes

- Defect of indoor unit PC board

Troubleshooting



Caution

Be sure to turn off power switch before connect or disconnect connector, or parts damage may be occurred.

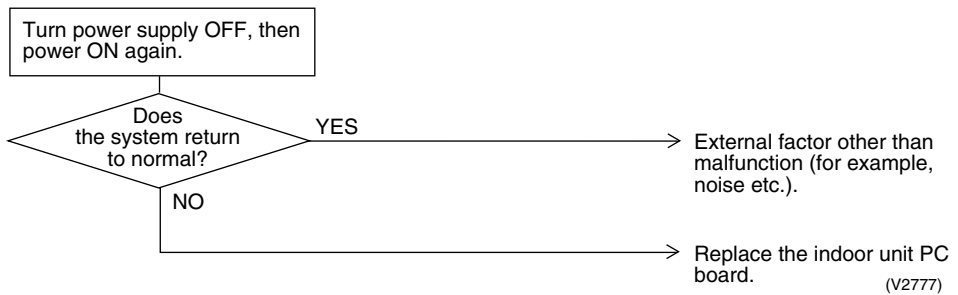

4.3 “A3” Indoor Unit: Malfunction of Drain Level Control System (S1L)

Remote Controller Display	A3
Applicable Models	FXFQ, FXSQ, FXMQ, FXHQ(Optional), FXAQ(Optional)
Method of Malfunction Detection	By float switch OFF detection
Malfunction Decision Conditions	When rise of water level is not a condition and the float switch goes OFF.
Supposed Causes	<ul style="list-style-type: none"> ■ 208~230V power supply is not provided ■ Defect of float switch or short circuit connector ■ Defect of drain pump ■ Drain clogging, upward slope, etc. ■ Defect of indoor unit PC board ■ Loose connection of connector

Troubleshooting



Caution

Be sure to turn off power switch before connect or disconnect connector, or parts damage may be occurred.

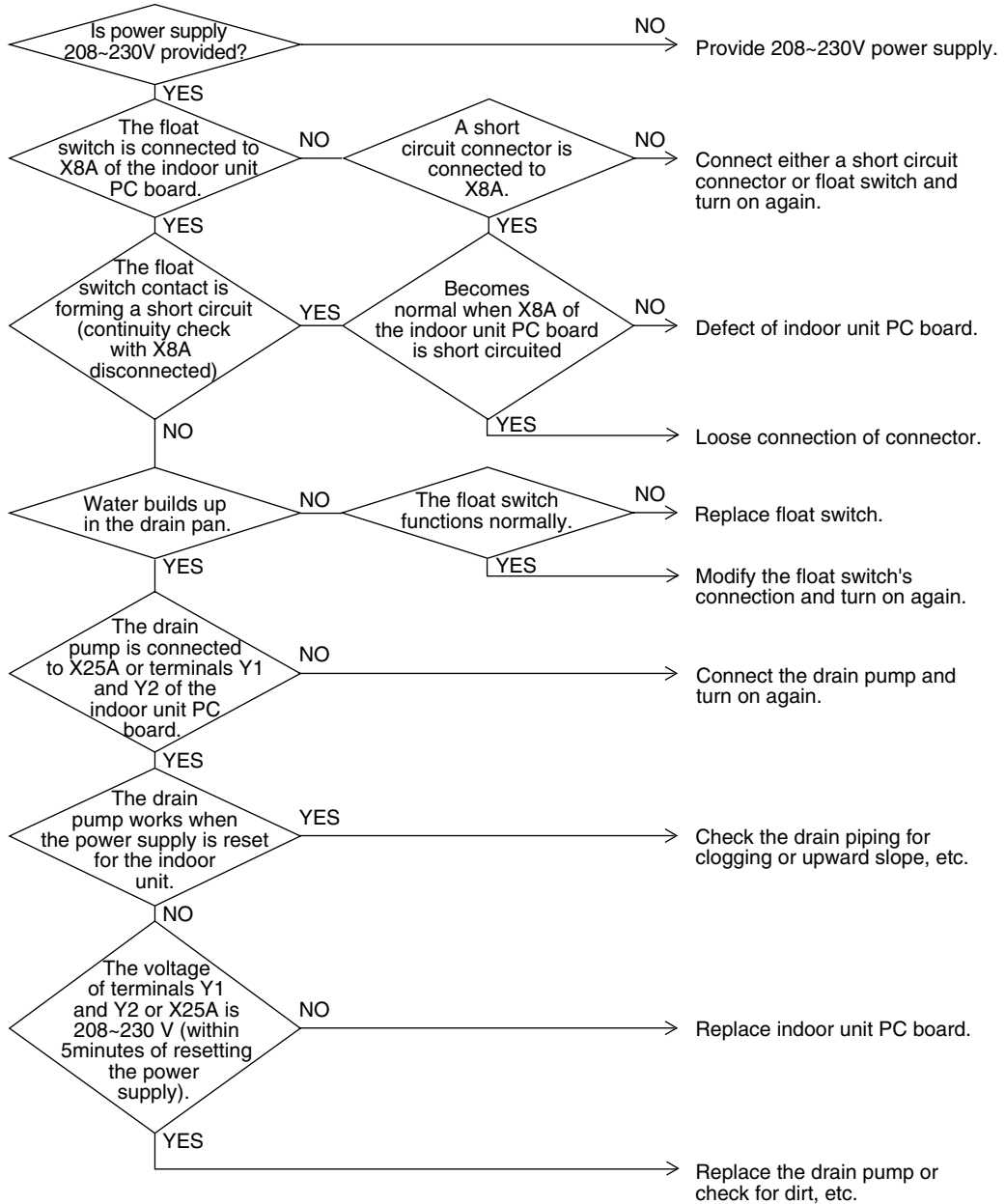

(V2778)

4.4 “A6” Indoor Unit: Fan Motor (M1F) Lock, Overload

Remote
Controller
Display

A6

Applicable
Models

All indoor unit models

Method of
Malfunction
Detection

Detection by failure of signal for detecting number of turns to come from the fan motor

Malfunction
Decision
Conditions

When number of turns can't be detected even when output voltage to the fan is maximum

Supposed
Causes

- Fan motor lock
- Disconnected or faulty wiring between fan motor and PC board

Troubleshooting



Caution

Be sure to turn off power switch before connect or disconnect connector, or parts damage may be occurred.

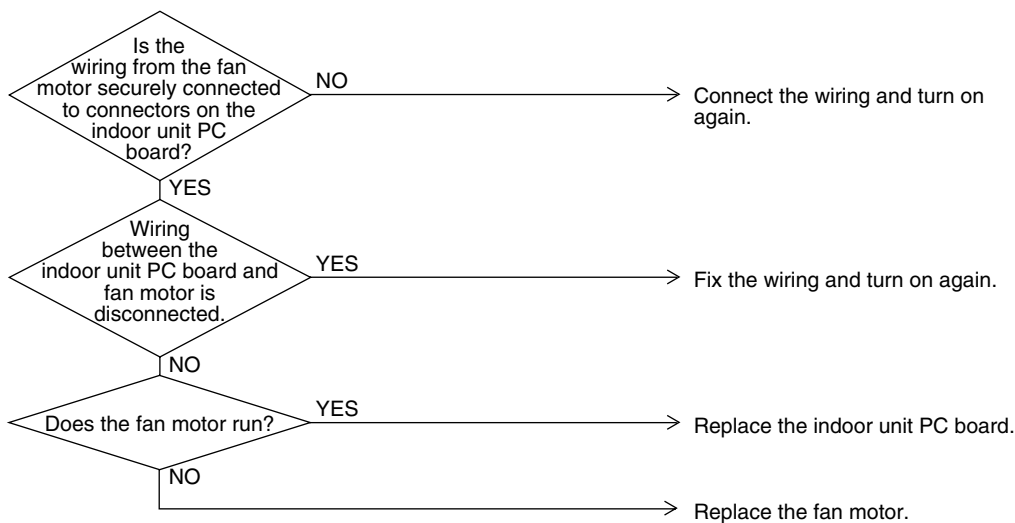

(V2779)

4.5 “A7” Indoor Unit: Malfunction of Swing Flap Motor (MA)

Remote
Controller
Display

A7

Applicable
Models

FXHQ

Method of
Malfunction
Detection

Utilizes ON/OFF of the limit switch when the motor turns.

Malfunction
Decision
Conditions

When ON/OFF of the microswitch for positioning cannot be reversed even though the swing flap motor is energized for a specified amount of time (about 30 seconds).

Supposed
Causes

- Defect of swing motor
- Defect of connection cable (power supply and limit switch)
- Defect of air flow direction adjusting flap-cam
- Defect of indoor unit PC board

Troubleshooting



Caution Be sure to turn off power switch before connect or disconnect connector, or parts damage may be occurred.

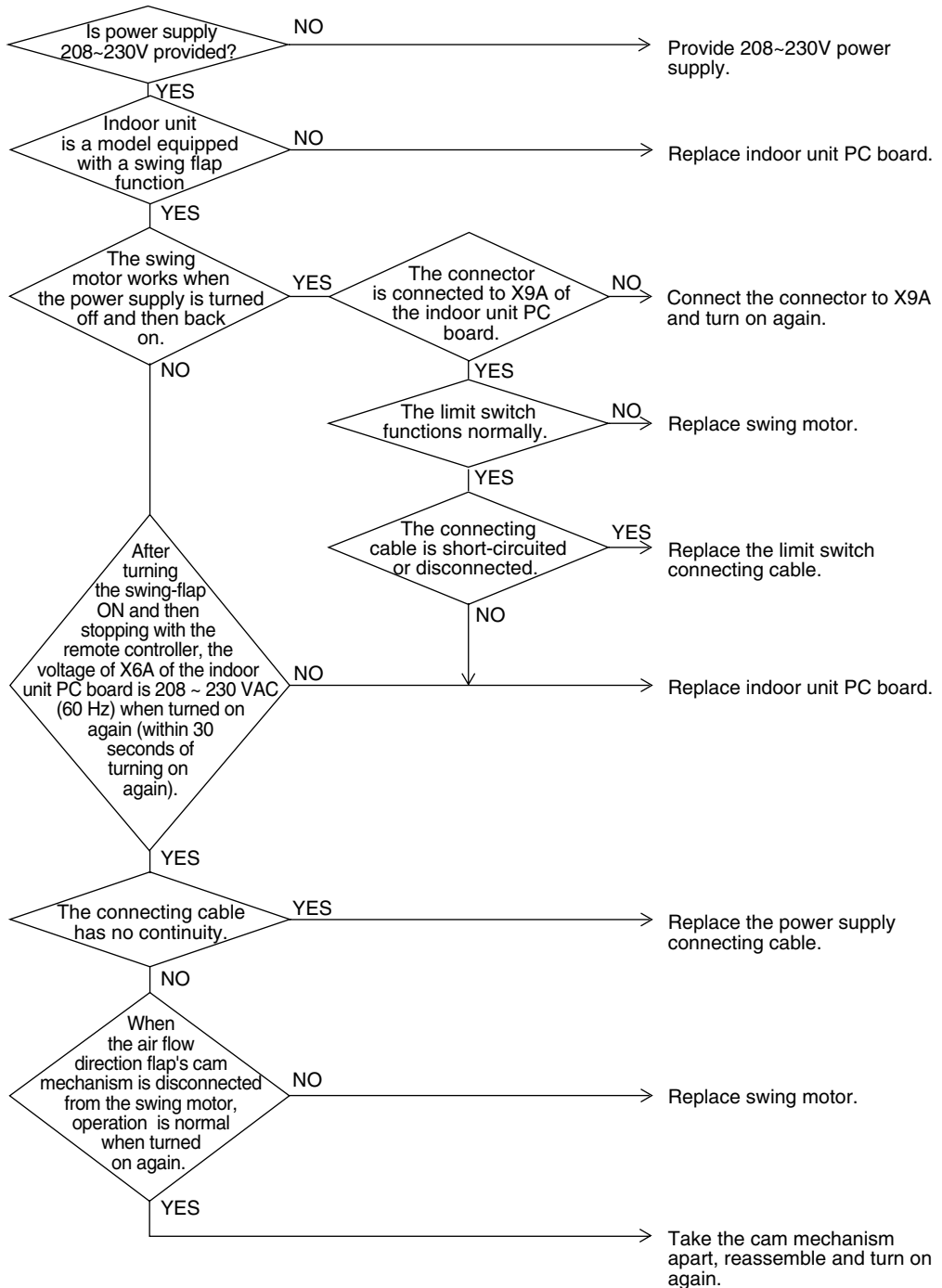

(V2780)

4.6 “A9” Indoor Unit: Malfunction of Moving Part of Electronic Expansion Valve (20E)

Remote Controller Display

A9

Applicable Models

All indoor unit models

Method of Malfunction Detection

Use a microcomputer to check the electronic expansion valve for coil conditions.

Malfunction Decision Conditions

When the pin input of the electronic expansion valve is not normal while in the initialization of the microcomputer.

Supposed Causes

- Malfunction of moving part of electronic expansion valve
- Defect of indoor unit PC board
- Defect of connecting cable

Troubleshooting



Caution

Be sure to turn off power switch before connect or disconnect connector, or parts damage may be occurred.

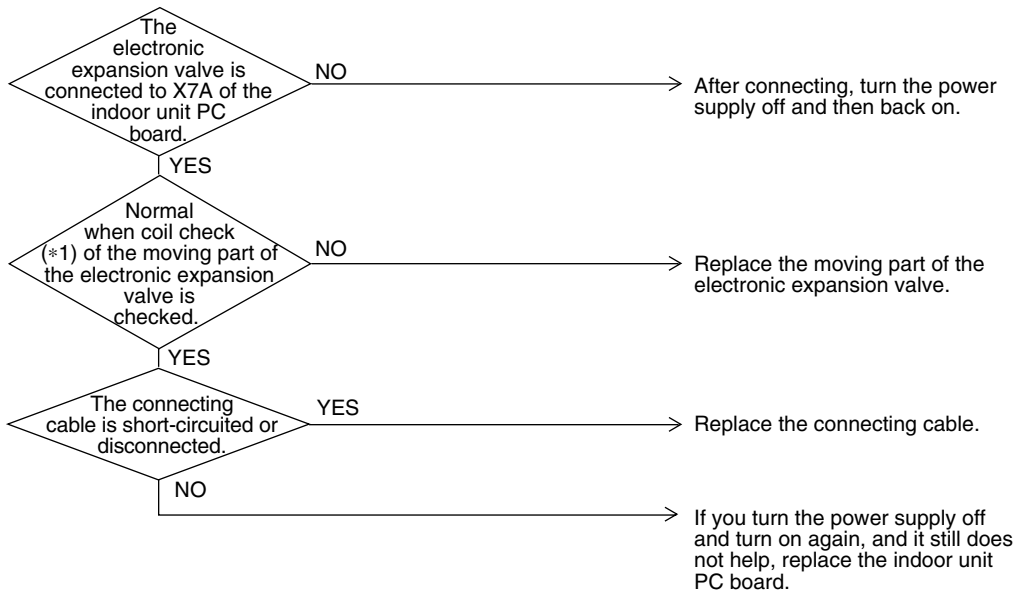

(V2781)

*1: Coil check method for the moving part of the electronic expansion valve
 Disconnect the electronic expansion valve from the PC board and check the continuity between the connector pins.

(Normal)

Pin No.	1. White	2. Yellow	3. Orange	4. Blue	5. Red	6. Brown
1. White		x	⊙ Approx. 300Ω	x	○ Approx. 150Ω	x
2. Yellow			x	⊙ Approx. 300Ω	x	○ Approx. 150Ω
3. Orange				x	○ Approx. 150Ω	x
4. Blue					x	○ Approx. 150Ω
5. Red						x
6. Brown						

⊙ : Continuity Approx. 300Ω

○ : Continuity Approx. 150Ω

x : No continuity

4.7 “AF” Indoor Unit: Drain Level above Limit

Remote Controller Display

AF

Applicable Models

FXFQ, FXSQ, FXMQ

Method of Malfunction Detection

Water leakage is detected based on float switch ON/OFF operation while the compressor is in non-operation.

Malfunction Decision Conditions

When the float switch changes from ON to OFF while the compressor is in non-operation.

Supposed Causes

- Humidifier unit (optional accessory) leaking
- Defect of drain pipe (upward slope, etc.)
- Defect of indoor unit PC board

Troubleshooting



Caution

Be sure to turn off power switch before connect or disconnect connector, or parts damage may be occurred.

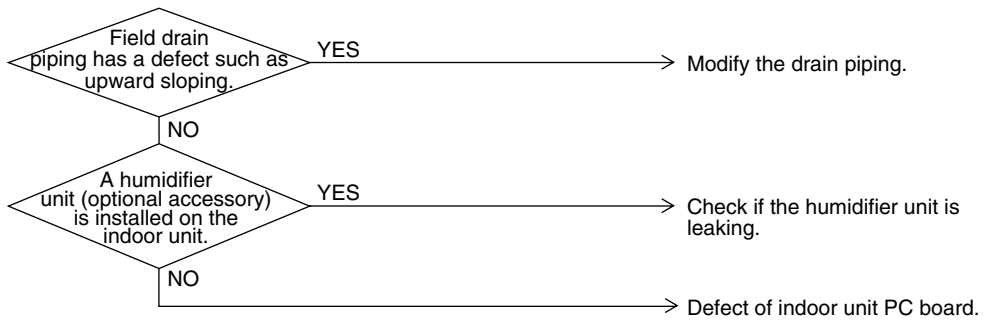

(V2782)

4.8 “AU” Indoor Unit: Malfunction of Capacity Determination Device

Remote controller display	AU
Applicable Models	All indoor unit models
Method of Malfunction Detection	Capacity is determined according to resistance of the capacity setting adaptor and the memory inside the IC memory on the indoor unit PC board, and whether the value is normal or abnormal is determined.
Malfunction Decision Conditions	<p>Operation and:</p> <ol style="list-style-type: none"> When the capacity code is not contained in the PC board’s memory, and the capacity setting adaptor is not connected. When a capacity that doesn’t exist for that unit is set.
Supposed Causes	<ul style="list-style-type: none"> ■ You have forgotten to install the capacity setting adaptor. ■ Defect of indoor unit PC board

Troubleshooting



Caution

Be sure to turn off power switch before connect or disconnect connector, or parts damage may be occurred.

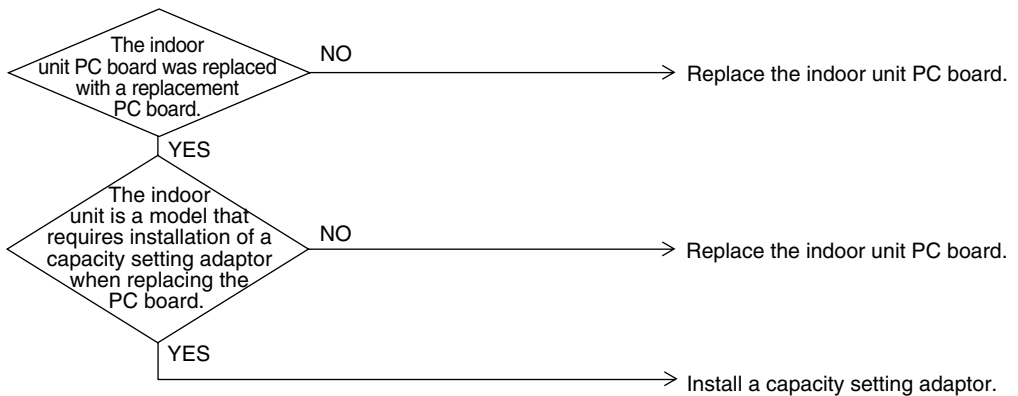

(V2783)

4.9 “E4” Indoor Unit: Malfunction of Thermistor (R2T) for Heat Exchanger

Remote Controller Display

E4

Applicable Models

All indoor unit models

Method of Malfunction Detection

Malfunction detection is carried out by temperature detected by heat exchanger thermistor.

Malfunction Decision Conditions

When the heat exchanger thermistor becomes disconnected or shorted while the unit is running.

Supposed Causes

- Defect of thermistor (R2T) for liquid pipe
- Defect of indoor unit PC board

Troubleshooting



Caution

Be sure to turn off power switch before connect or disconnect connector, or parts damage may be occurred.

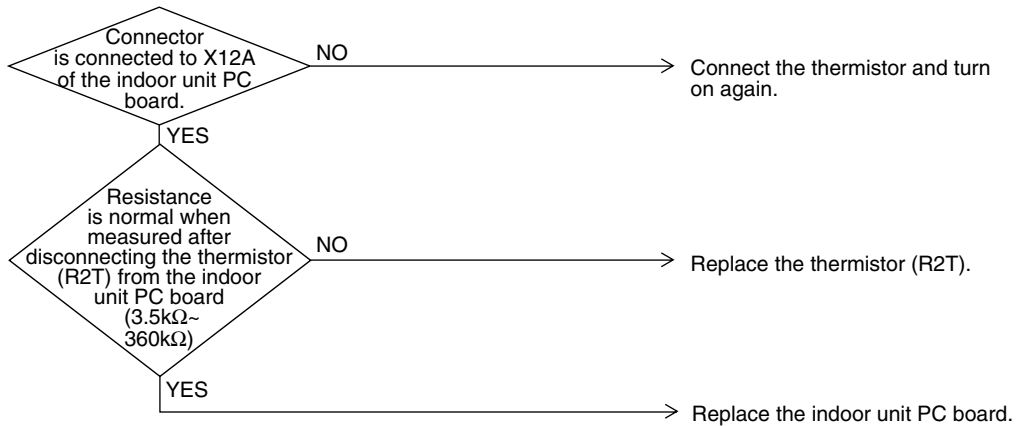

(V2784)



* Refer to “Thermistor Resistance / Temperature Characteristics” table on P190.

4.10 “E5” Indoor Unit: Malfunction of Thermistor (R3T) for Gas Pipes

Remote Controller Display	E5
Applicable Models	All indoor unit models
Method of Malfunction Detection	Malfunction detection is carried out by temperature detected by gas pipe thermistor.
Malfunction Decision Conditions	When the gas pipe thermistor becomes disconnected or shorted while the unit is running.
Supposed Causes	<ul style="list-style-type: none"> ■ Defect of indoor unit thermistor (R3T) for gas pipe ■ Defect of indoor unit PC board

Troubleshooting



Caution

Be sure to turn off power switch before connect or disconnect connector, or parts damage may be occurred.

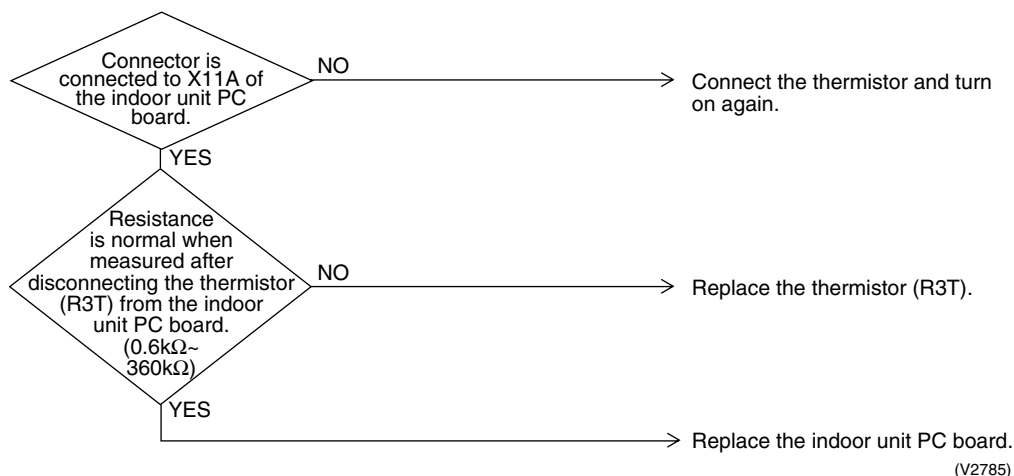

(V2785)



* Refer to “Thermistor Resistance / Temperature Characteristics” table on P190.

4.11 “C9” Indoor Unit: Malfunction of Thermistor (R1T) for Suction Air

Remote Controller Display

C9

Applicable Models

All indoor unit models

Method of Malfunction Detection

Malfunction detection is carried out by temperature detected by suction air temperature thermistor.

Malfunction Decision Conditions

When the suction air temperature thermistor becomes disconnected or shorted while the unit is running.

Supposed Causes

- Defect of indoor unit thermistor (R1T) for air inlet
- Defect of indoor unit PC board

Troubleshooting



Caution

Be sure to turn off power switch before connect or disconnect connector, or parts damage may be occurred.

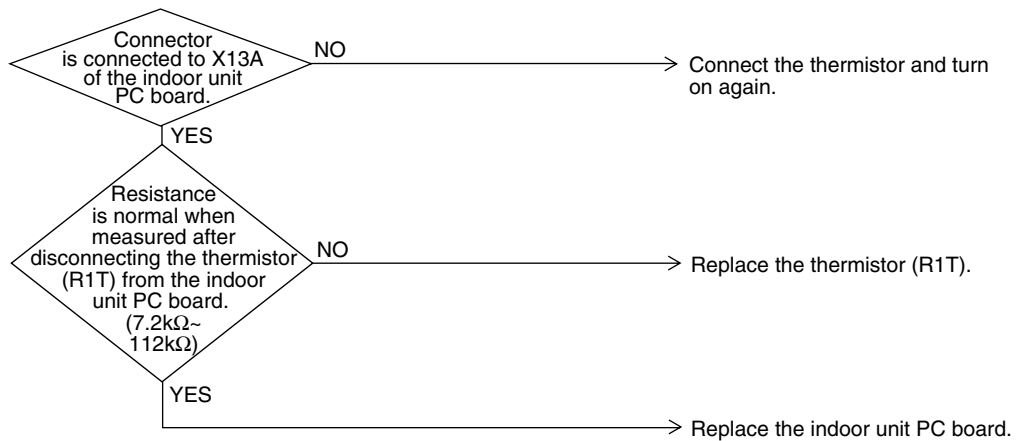

(V2786)



* Refer to “Thermistor Resistance / Temperature Characteristics” table on P190.

4.12 “CR” Indoor Unit: Malfunction of Thermistor for Discharge Air

Remote Controller Display	CR
Applicable Models	All indoor unit models
Method of Malfunction Detection	Malfunction detection is carried out by temperature detected by discharge air temperature thermistor.
Malfunction Decision Conditions	When the discharge air temperature thermistor becomes disconnected or shorted while the unit is running.
Supposed Causes	<ul style="list-style-type: none"> ■ Defect of indoor unit thermistor for air outlet ■ Defect of indoor unit PC board

Troubleshooting



Caution

Be sure to turn off power switch before connect or disconnect connector, or parts damage may be occurred.

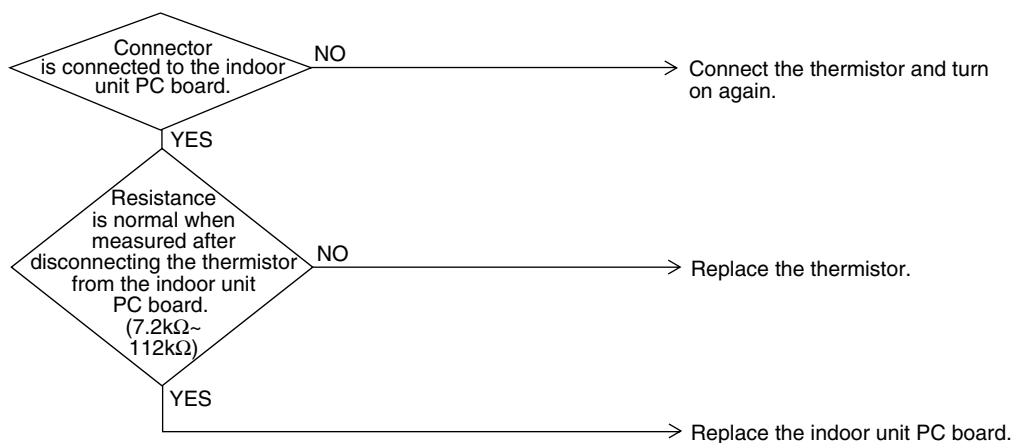

(V2786)



* Refer to “Thermistor Resistance / Temperature Characteristics” table on P190.

4.13 “CJ” Indoor Unit: Malfunction of Thermostat Sensor in Remote Controller

Remote Controller Display	CJ
Applicable Models	All indoor unit models
Method of Malfunction Detection	Malfunction detection is carried out by temperature detected by remote controller air temperature thermistor. (Note:)
Malfunction Decision Conditions	When the remote controller air temperature thermistor becomes disconnected or shorted while the unit is running.
Supposed Causes	<ul style="list-style-type: none"> ■ Defect of remote controller thermistor ■ Defect of remote controller PC board

Troubleshooting



Caution

Be sure to turn off power switch before connect or disconnect connector, or parts damage may be occurred.

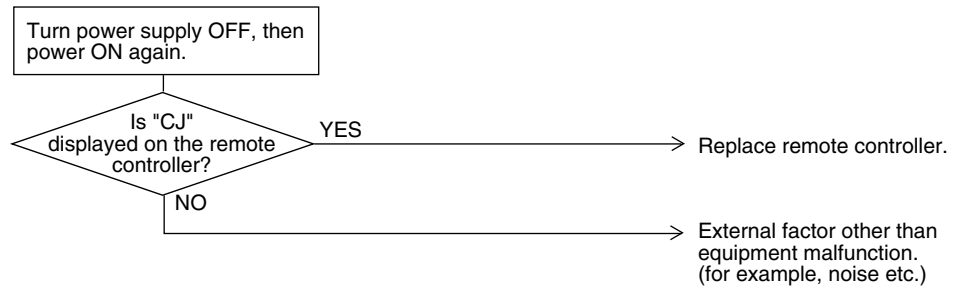

(V2787)



Note:

In case of remote controller thermistor malfunction, unit is still operable by suction air thermistor on indoor unit.



* Refer to “Thermistor Resistance / Temperature Characteristics” table on P190.

4.14 “E1” Outdoor Unit: PC Board Defect

Remote
Controller
Display

E1

Applicable
Models

All outdoor unit models

Method of
Malfunction
Detection

Check data from E²PROM

Malfunction
Decision
Conditions

When data could not be correctly received from the E²PROM
E²PROM : Type of nonvolatile memory. Maintains memory contents even when the power supply is turned off.

Supposed
Causes

- Defect of outdoor unit PC board (A1P)

Troubleshooting



Caution

Be sure to turn off power switch before connect or disconnect connector, or parts damage may be occurred.

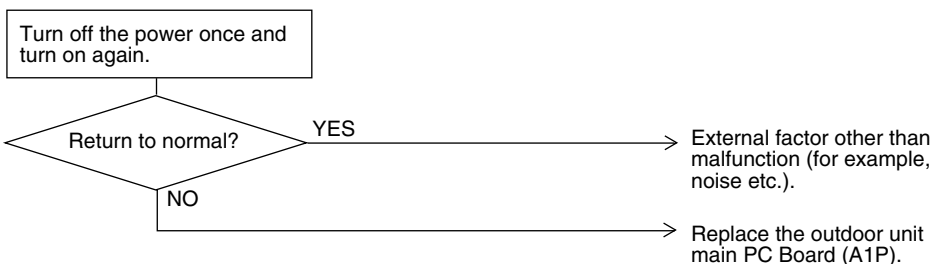

(V3064)

4.15 “E3” Outdoor Unit: Actuation of High Pressure Switch

Remote
Controller
Display

E3

Applicable
Models

All outdoor unit models

Method of
Malfunction
Detection

Abnormality is detected when the contact of the high pressure protection switch opens.

Malfunction
Decision
Conditions

Error is generated when the HPS activation count reaches the number specific to the operation mode.

Supposed
Causes

- Actuation of outdoor unit high pressure switch
- Defect of High pressure switch
- Defect of outdoor unit PC board
- Instantaneous power failure
- Faulty high pressure sensor

Troubleshooting



Caution

Be sure to turn off power switch before connect or disconnect connector, or parts damage may be occurred.

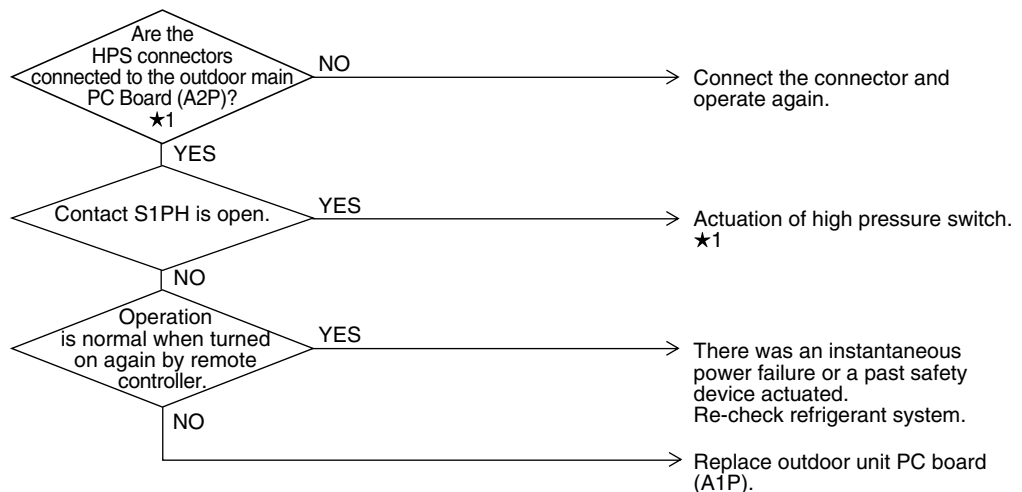

(V3065)

★1: Actuation of high pressure switch (HPS)

- Is the outdoor unit heat exchanger dirty?
- Defect of outdoor fan
- Is the refrigerant over-charged?
- Faulty high pressure sensor

4.16 “E4” Outdoor Unit: Actuation of Low Pressure Switch

Remote
Controller
Display

E4

Applicable
Models

All outdoor unit models

Method of
Malfunction
Detection

Abnormality is detected by pressure value with low pressure sensor.

Malfunction
Decision
Conditions

Error is generated when the low pressure is dropped under specific pressure.

Supposed
Causes

- Abnormal drop of low pressure
- Defect of low pressure sensor
- Defect of outdoor unit PC board
- Stop valve is not opened.

Troubleshooting



Caution Be sure to turn off power switch before connect or disconnect connector, or parts damage may be occurred.

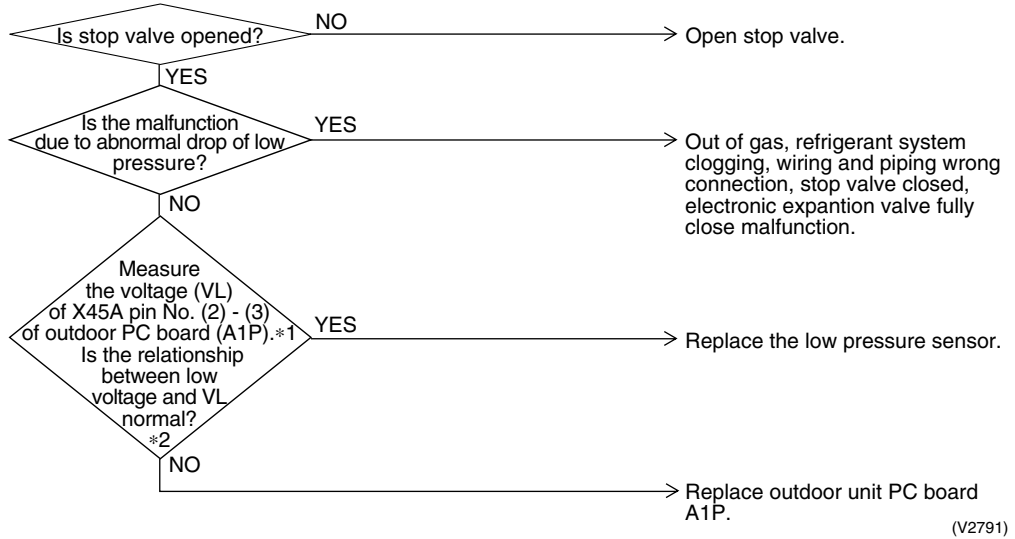

(V2791)

*1: Voltage measurement point

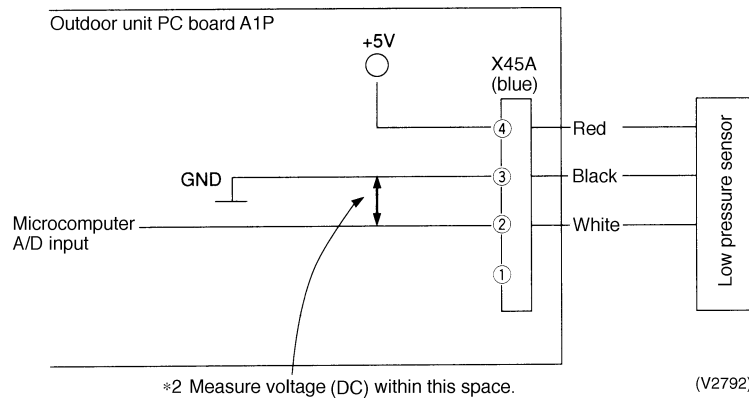

(V2792)



*2: Refer to "Pressure Sensor", pressure / voltage characteristics table on P192.

4.17 “E5” Outdoor Unit: Compressor Motor Lock

Remote Controller Display	<i>E5</i>
Applicable Models	All outdoor unit models
Method of Malfunction Detection	Inverter PC board takes the position signal from UVWN line connected between the inverter and compressor, and detects the position signal pattern.
Malfunction Decision Conditions	The position signal with 3 times cycle as imposed frequency is detected when compressor motor operates normally, but 2 times cycle when compressor motor locks. When the position signal in 2 times cycle is detected.
Supposed Causes	<ul style="list-style-type: none"> ■ Compressor lock ■ High differential pressure (73 psi or more) ■ Incorrect UVWN wiring ■ Faulty inverter PC board ■ Stop valve is left in closed.

Troubleshooting

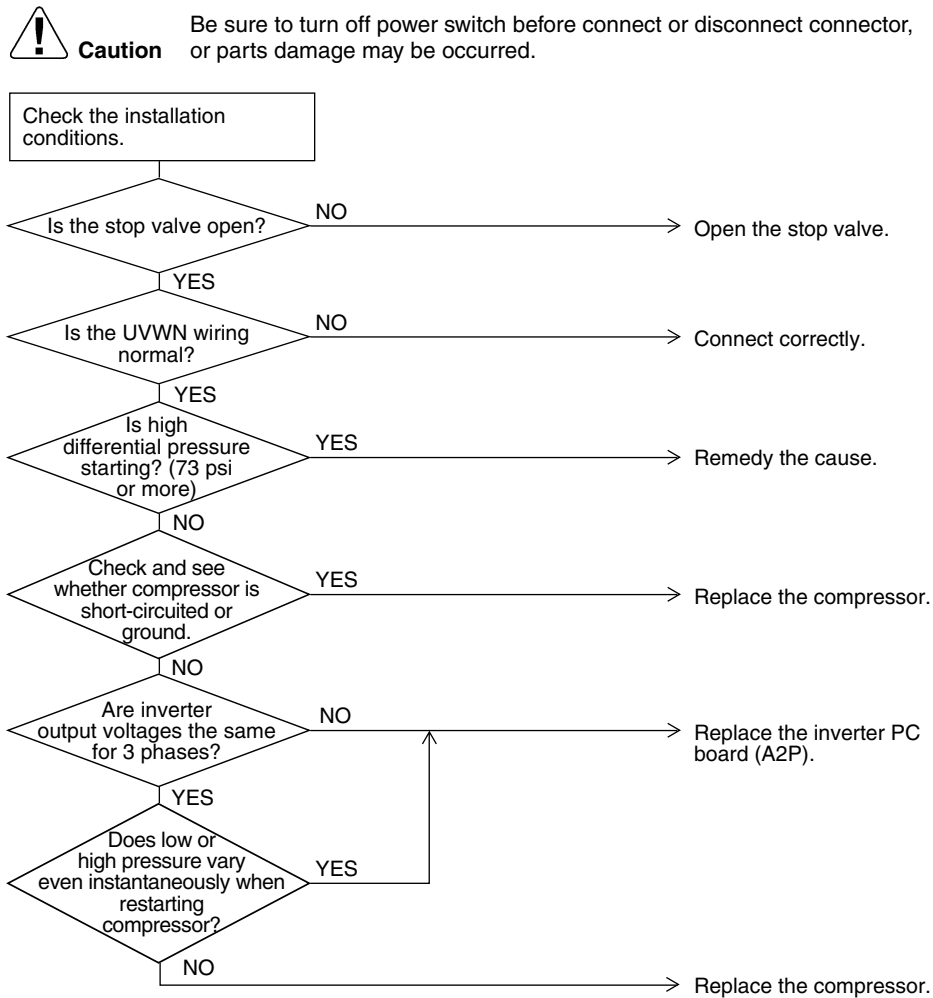

(V2793)

4.18 “E7” Outdoor Unit: Malfunction of Outdoor Unit Fan Motor

Remote Controller Display	<i>E7</i>
Applicable Models	All outdoor unit models
Method of Malfunction Detection	Malfunction of fan motor system is detected according to the fan speed detected by hall IC when the fan motor runs.
Malfunction Decision Conditions	<ul style="list-style-type: none">■ When the fan runs with speed less than a specified one for 14.5 seconds or more when the fan motor running conditions are met■ When malfunction is generated 4 times, the system shuts down.
Supposed Causes	<ul style="list-style-type: none">■ Malfunction of fan motor■ The harness connector between fan motor and PC board is left in disconnected, or faulty connector■ Fan does not run due to foreign matters tangled■ Clearing condition: Operate for 5 minutes (normal)

Troubleshooting

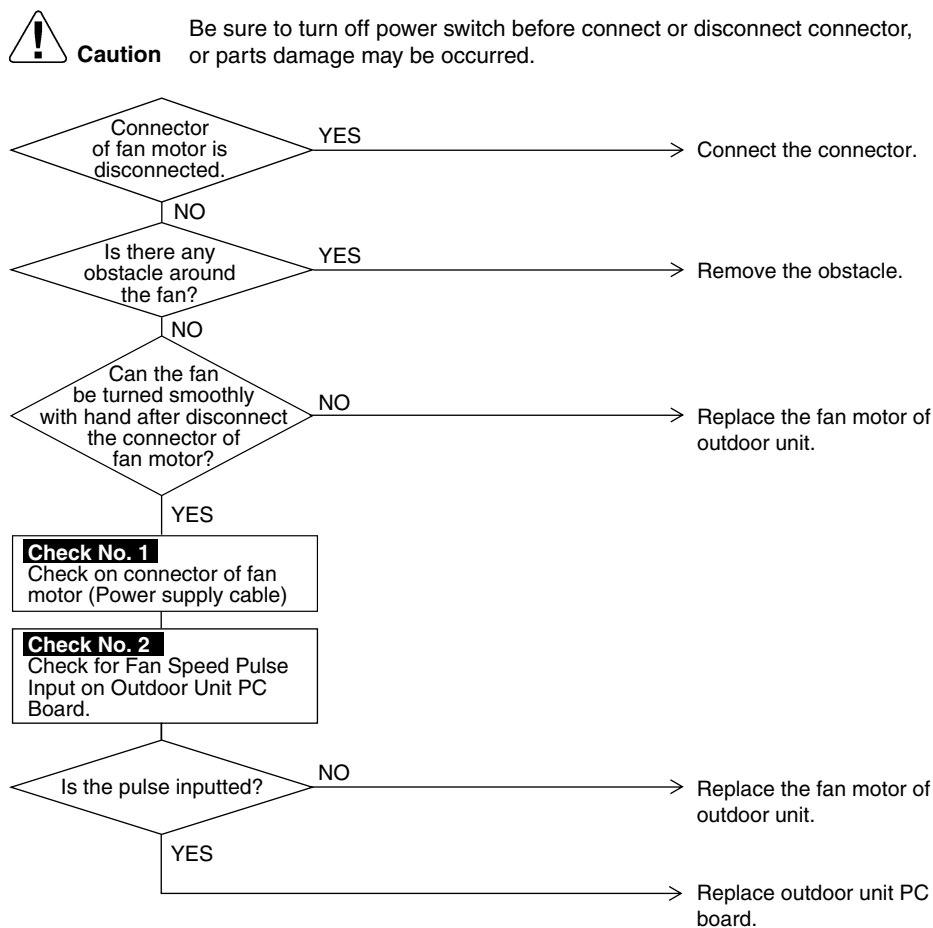

(V3077)



Check No. 1: Refer to P181.
Check No. 2: Refer to P182.

4.19 “E9” Outdoor Unit: Malfunction of Moving Part of Electronic Expansion Valve

Remote Controller Display

E9

Applicable Models

All outdoor unit models

Method of Malfunction Detection

Check disconnection of connector
Check continuity of expansion valve coil

Malfunction Decision Conditions

Error is generated under no common power supply when the power is on.

Supposed Causes

- Defect of moving part of electronic expansion valve
- Defect of outdoor unit PC board (A1P)

Troubleshooting



Caution

Be sure to turn off power switch before connect or disconnect connector, or parts damage may be occurred.

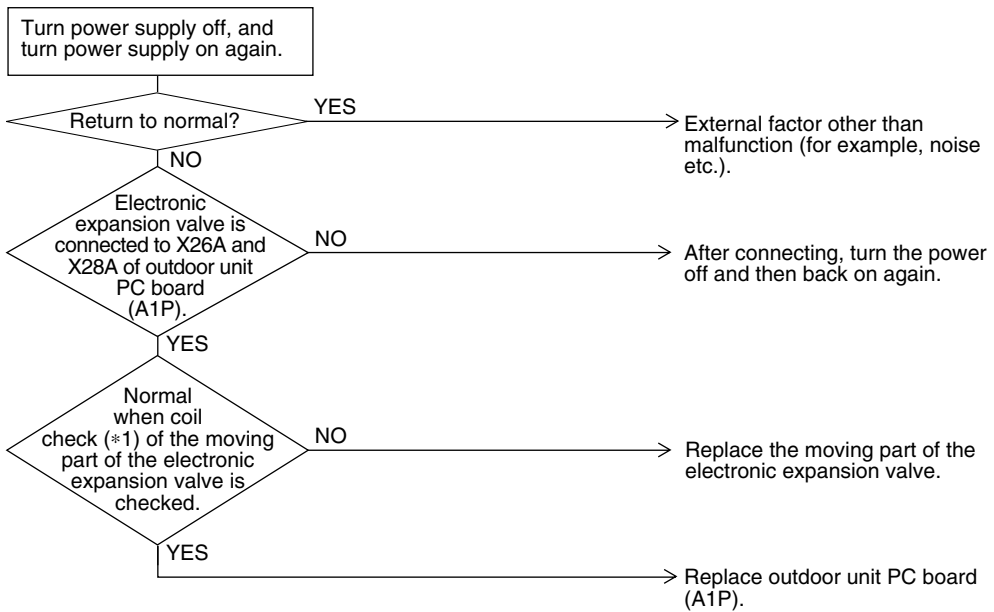

(V3067)

*1 Coil check method for the moving part of the electronic expansion valve
 Disconnect the electronic expansion valve from the PC board and check the continuity between the connector pins.

(Normal)

Pin No.	1. White	2. Yellow	3. Orange	4. Blue	5. Red	6. Brown
1. White		x	⊙ Approx. 300Ω	x	○ Approx. 150Ω	x
2. Yellow			x	⊙ Approx. 300Ω	x	○ Approx. 150Ω
3. Orange				x	○ Approx. 150Ω	x
4. Blue					x	○ Approx. 150Ω
5. Red						x
6. Brown						

⊙ : Continuity Approx. 300Ω

○ : Continuity Approx. 150Ω

x : No continuity

4.20 “F3” Outdoor Unit: Abnormal Discharge Pipe Temperature

Remote Controller Display	F3
Applicable Models	All outdoor unit models
Method of Malfunction Detection	Abnormality is detected according to the temperature detected by the discharge pipe temperature sensor.
Malfunction Decision Conditions	<ul style="list-style-type: none"> ■ When the discharge pipe temperature rises to an abnormally high level ■ When the discharge pipe temperature rises suddenly
Supposed Causes	<ul style="list-style-type: none"> ■ Faulty discharge pipe temperature ■ Faulty connection of discharge pipe thermistor ■ Faulty outdoor unit PC board

Troubleshooting



Caution

Be sure to turn off power switch before connect or disconnect connector, or parts damage may be occurred.

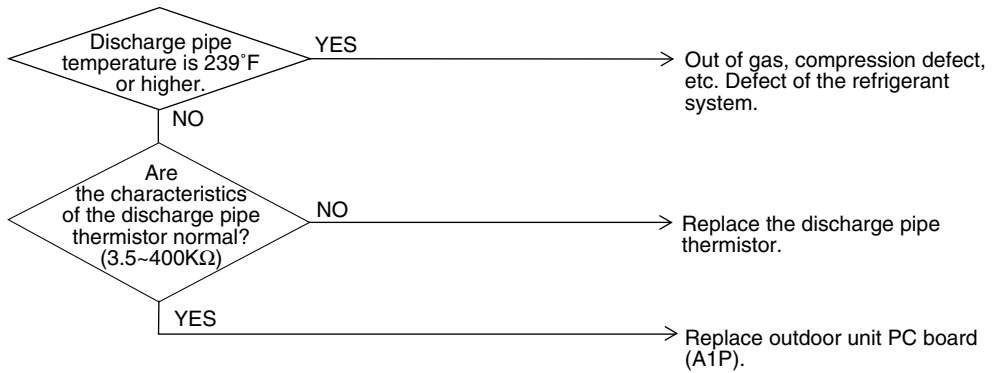

(V3182)



* Refer to “Thermistor Resistance / Temperature Characteristics” table on P190.

4.21 “H9” Outdoor Unit: Malfunction of Thermistor (R1T) for Outdoor Air

Remote Controller Display	H9
Applicable Models	All outdoor unit models
Method of Malfunction Detection	The abnormal detection is based on current detected by current sensor.
Malfunction Decision Conditions	When the outside air temperature sensor has short circuit or open circuit.
Supposed Causes	<ul style="list-style-type: none"> ■ Defect of thermistor (R1T) for outdoor air ■ Defect of outdoor unit PC board (A1P)

Troubleshooting



Caution

Be sure to turn off power switch before connect or disconnect connector, or parts damage may be occurred.

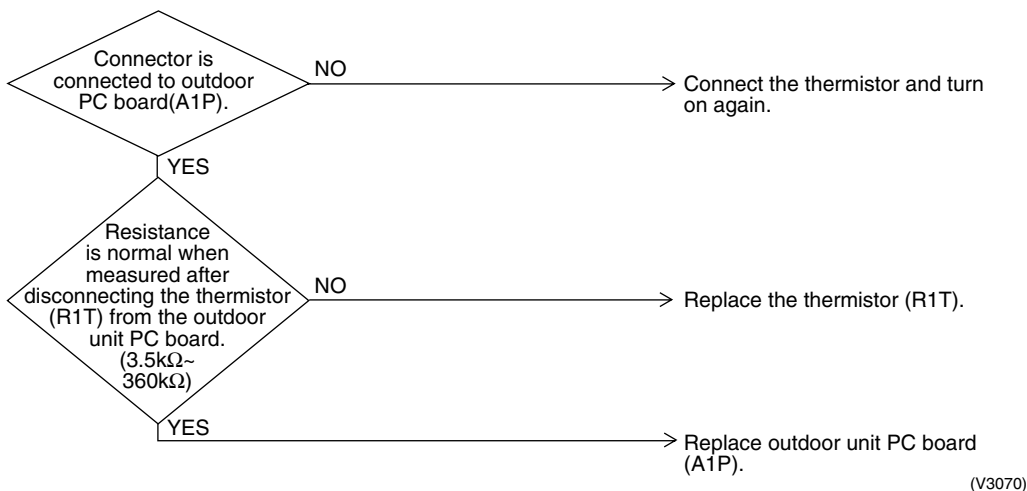

The alarm indicator is displayed when the fan only is being used also.



* Refer to “Thermistor Resistance / Temperature Characteristics” table on P190.

4.22 “J3” Outdoor Unit: Malfunction of Discharge Pipe Thermistor (R3T)

Remote Controller Display

J3

Applicable Models

All outdoor unit models

Method of Malfunction Detection

Malfunction is detected from the temperature detected by discharge pipe temperature thermistor.

Malfunction Decision Conditions

When a short circuit or an open circuit in the discharge pipe temperature thermistor is detected.

Supposed Causes

- Defect of thermistor (R3T) for outdoor unit discharge pipe
- Defect of outdoor unit PC board (A1P)

Troubleshooting



Caution

Be sure to turn off power switch before connect or disconnect connector, or parts damage may be occurred.

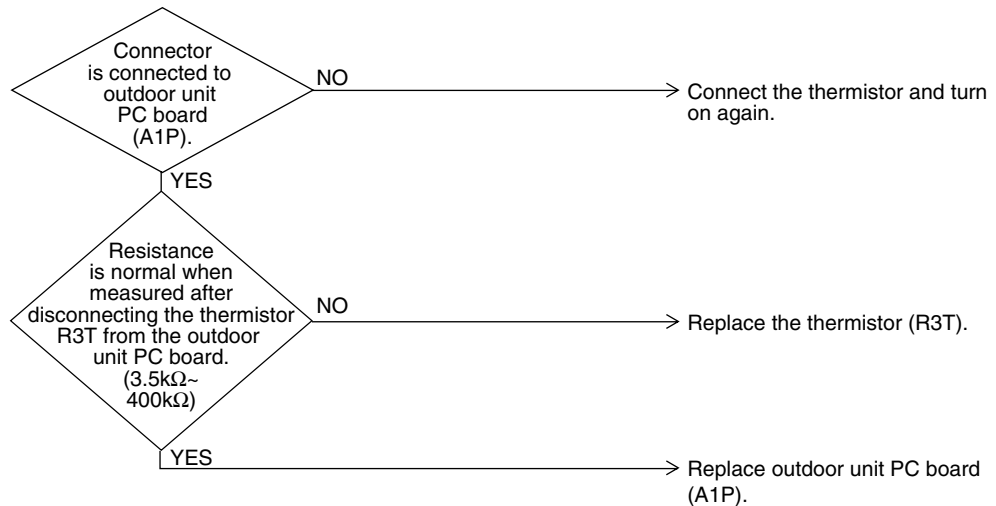

(V3072)



* Refer to “Thermistor Resistance / Temperature Characteristics” table on P190.

4.23 “J5” Outdoor Unit: Malfunction of Thermistor (R2T) for Suction Pipe

Remote Controller Display	J5
Applicable Models	All outdoor unit models
Method of Malfunction Detection	Malfunction is detected from the temperature detected by the suction pipe temperature thermistor.
Malfunction Decision Conditions	When a short circuit or an open circuit in the suction pipe temperature thermistor is detected.
Supposed Causes	<ul style="list-style-type: none"> ■ Defect of thermistor (R2T) for outdoor unit suction pipe ■ Defect of outdoor unit PC board (A1P)

Troubleshooting



Caution

Be sure to turn off power switch before connect or disconnect connector, or parts damage may be occurred.

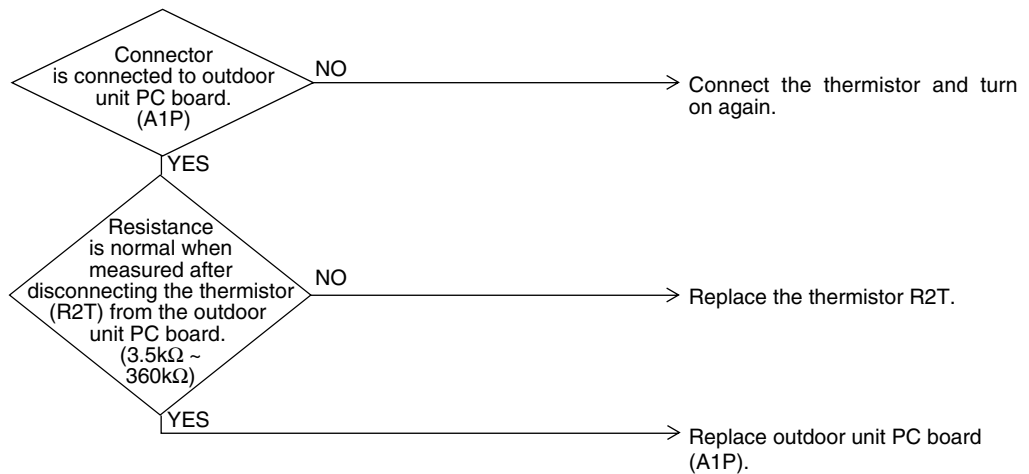

(V3073)



* Refer to “Thermistor Resistance / Temperature Characteristics” table on P190.

4.24 “J5” Outdoor Unit: Malfunction of Thermistor (R4T) for Outdoor Unit Heat Exchanger

Remote Controller Display

J5

Applicable Models

All outdoor unit models

Method of Malfunction Detection

Malfunction is detected from the temperature detected by the heat exchanger thermistor.

Malfunction Decision Conditions

When a short circuit or an open circuit in the heat exchange thermistor is detected.

Supposed Causes

- Defect of thermistor (R4T) for outdoor unit heat exchanger
- Defect of outdoor unit PC board (A1P)

Troubleshooting



Caution

Be sure to turn off power switch before connect or disconnect connector, or parts damage may be occurred.

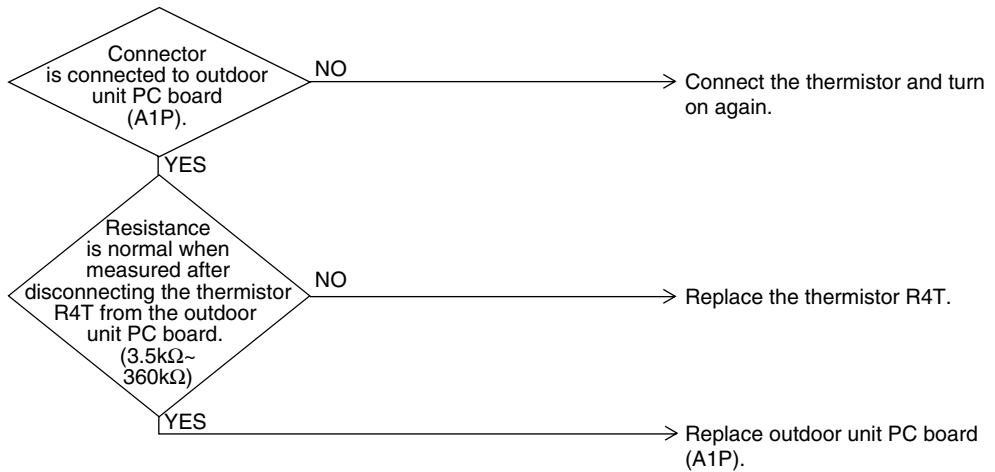

(V3074)



* Refer to “Thermistor Resistance / Temperature Characteristics” table on P190.

4.25 “J9” Outdoor Unit: Malfunction of Subcooling Heat Exchanger Gas Pipe Thermistor (R5T)

Remote Controller Display	J9
Applicable Models	All outdoor unit models
Method of Malfunction Detection	Malfunction is detected according to the temperature detected by subcooling heat exchanger gas pipe thermistor.
Malfunction Decision Conditions	When the subcooling heat exchanger gas pipe thermistor is short circuited or open.
Supposed Causes	<ul style="list-style-type: none"> ■ Faulty subcooling heat exchanger gas pipe thermistor (R5T) ■ Faulty outdoor unit PC board

Troubleshooting



Caution

Be sure to turn off power switch before connect or disconnect connector, or parts damage may be occurred.

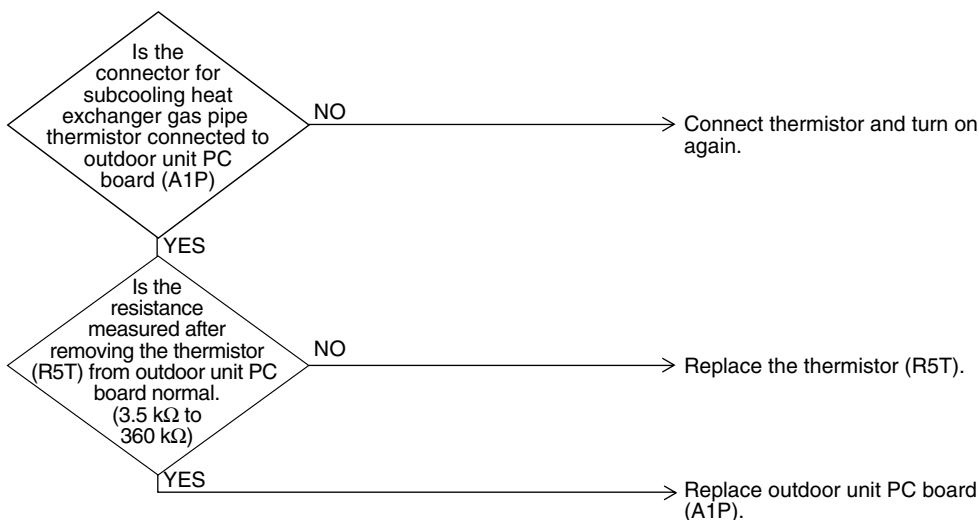

(V3075)



* Refer to “Thermistor Resistance / Temperature Characteristics” table on P190.

4.26 “JA” Outdoor Unit: Malfunction of High Pressure Sensor

Remote
Controller
Display

JA

Applicable
Models

All outdoor unit models

Method of
Malfunction
Detection

Malfunction is detected from the pressure detected by the high pressure sensor.

Malfunction
Decision
Conditions

When the high pressure sensor is short circuit or open circuit.

Supposed
Causes

- Defect of high pressure sensor
- Connection of low pressure sensor with wrong connection.
- Defect of outdoor unit PC board.

Troubleshooting



Caution

Be sure to turn off power switch before connect or disconnect connector, or parts damage may be occurred.

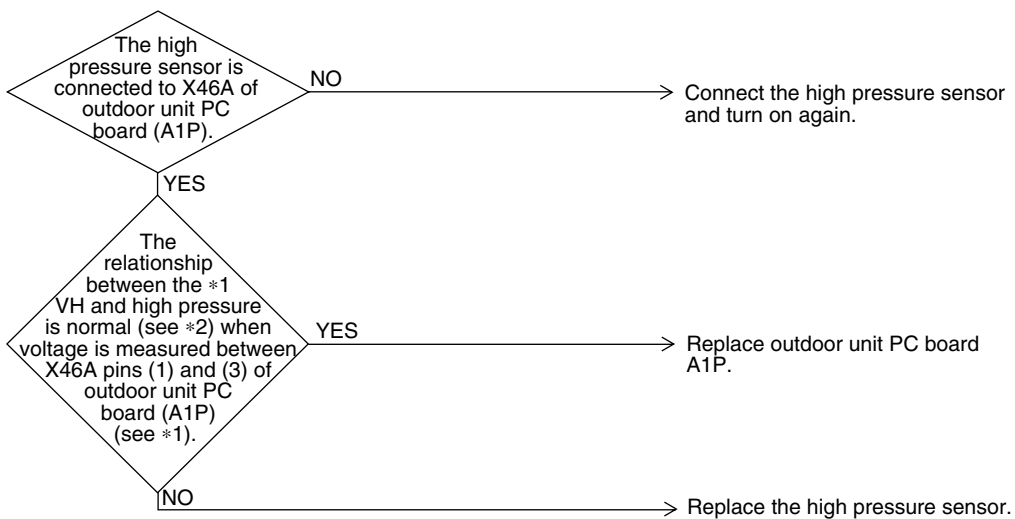

(V2806)

*1: Voltage measurement point

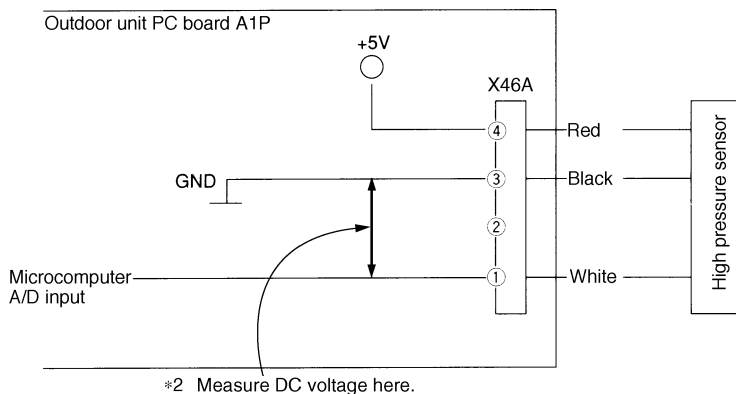

(V2807)



*2: Refer to "Pressure Sensor", pressure / voltage characteristics table on P192.

4.27 “JC” Outdoor Unit: Malfunction of Low Pressure Sensor

Remote Controller Display



Applicable Models

All outdoor unit models

Method of Malfunction Detection

Malfunction is detected from pressure detected by low pressure sensor.

Malfunction Decision Conditions

When the low pressure sensor is short circuit or open circuit.

Supposed Causes

- Defect of low pressure sensor
- Connection of high pressure sensor with wrong connection.
- Defect of outdoor unit PC board.

Troubleshooting



Caution

Be sure to turn off power switch before connect or disconnect connector, or parts damage may be occurred.

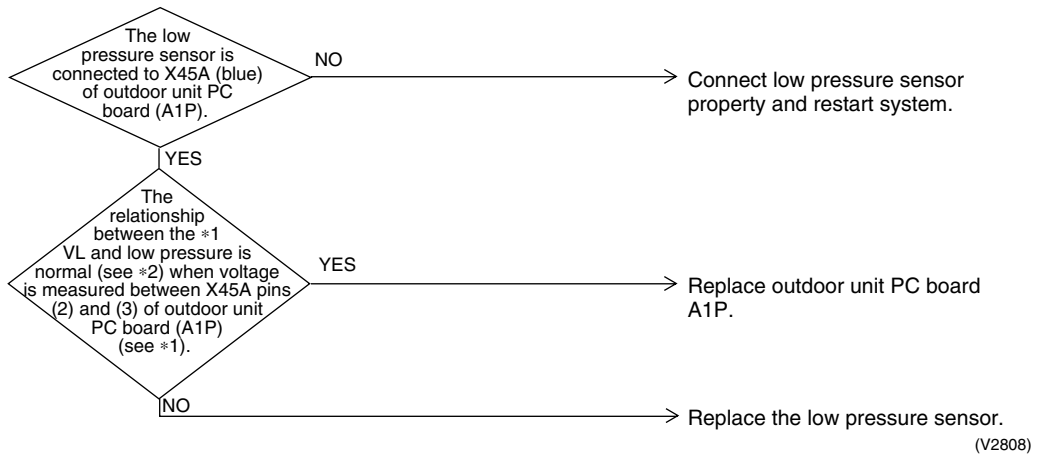

*1: Voltage measurement point

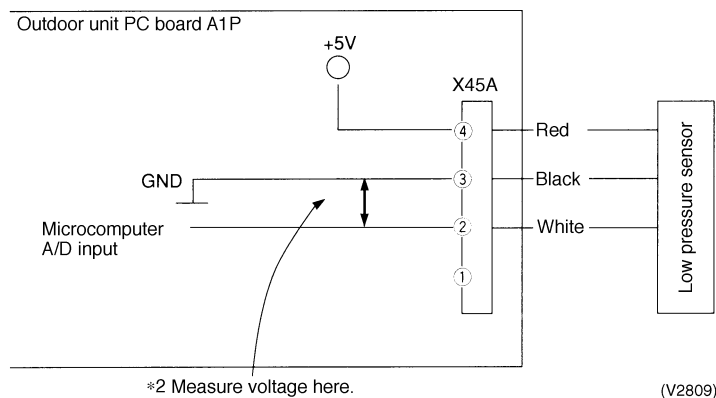

*2: Refer to “Pressure Sensor”, pressure/voltage characteristics table on P192.

4.28 “L4” Outdoor Unit: Malfunction of Inverter Radiating Fin Temperature Rise

Remote Controller Display

L4

Applicable Models

All outdoor unit models

Method of Malfunction Detection

Fin temperature is detected by the thermistor of the radiation fin.

Malfunction Decision Conditions

When the temperature of the inverter radiation fin increases above 210°F.

Supposed Causes

- Actuation of fin thermal (Actuates above 210°F)
- Defect of inverter PC board
- Defect of fin thermistor

Troubleshooting



Caution

Be sure to turn off power switch before connect or disconnect connector, or parts damage may be occurred.

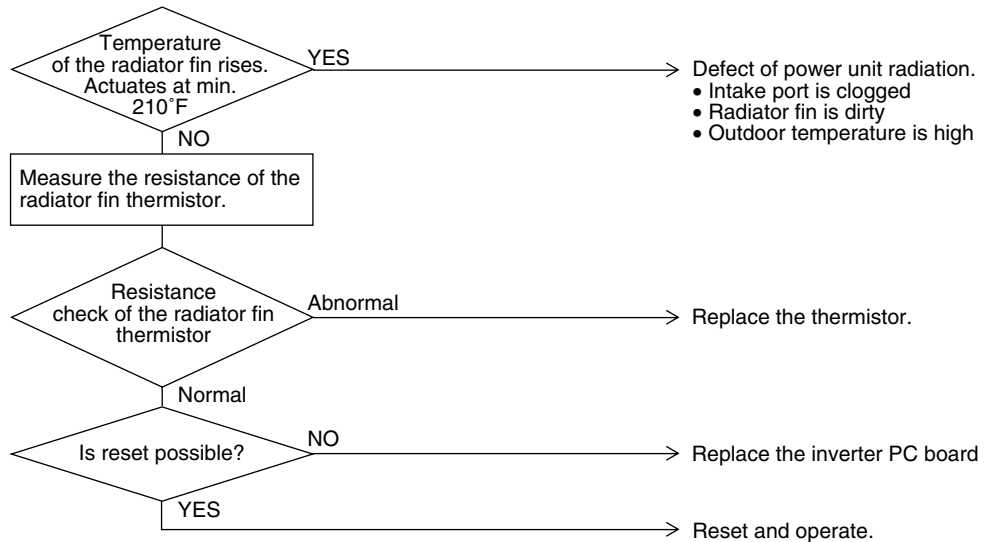

(V3183)



* Refer to “Thermistor Resistance / Temperature Characteristics” table on P190.

4.29 “L5” Outdoor Unit: Inverter Compressor Abnormal

Remote Controller Display

L5

Applicable Models

All outdoor unit models

Method of Malfunction Detection

Malfunction is detected from current flowing in the power transistor.

Malfunction Decision Conditions

When an excessive current flows in the power transistor. (Instantaneous overcurrent also causes activation.)

Supposed Causes

- Defect of compressor coil (disconnected, defective insulation)
- Compressor start-up malfunction (mechanical lock)
- Defect of inverter PC board

Troubleshooting



Caution

Be sure to turn off power switch before connect or disconnect connector, or parts damage may be occurred.

Compressor inspection

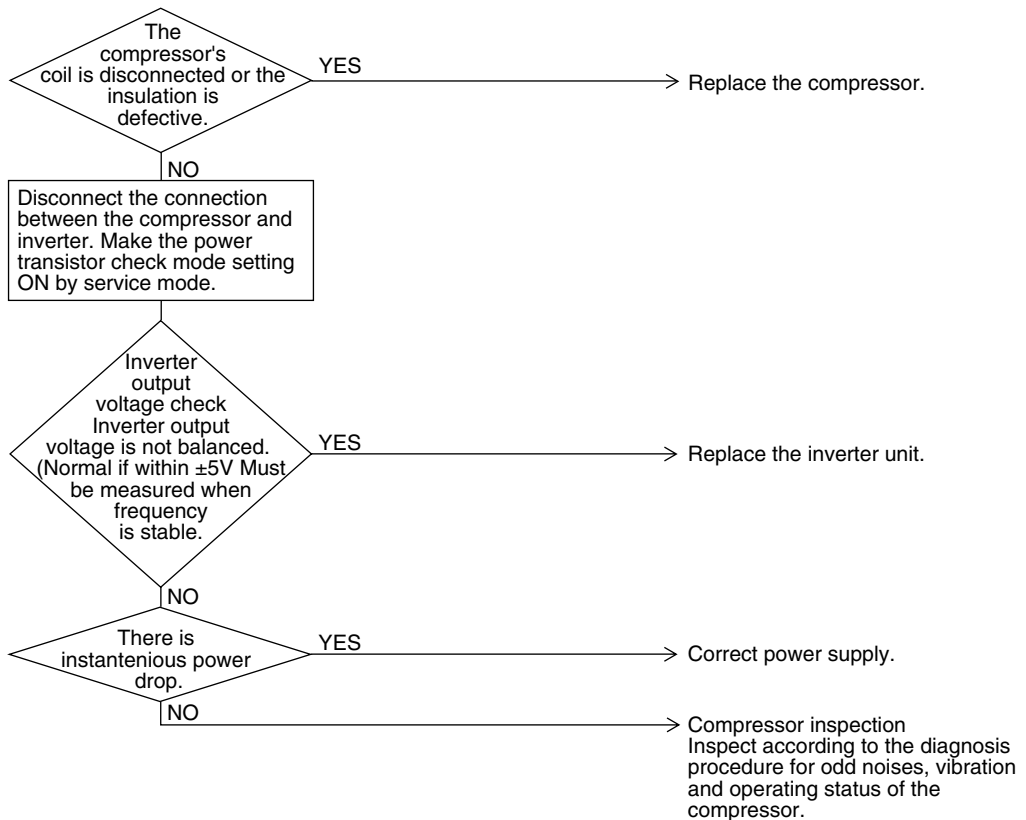

(V2812)

Higher voltage than actual is displayed when the inverter output voltage is checked by tester.

4.30 “L8” Outdoor Unit: Inverter Current Abnormal

Remote
Controller
Display

L8

Applicable
Models

All outdoor unit models

Method of
Malfunction
Detection

Malfunction is detected by current flowing in the power transistor.

Malfunction
Decision
Conditions

When overload in the compressor is detected.

Supposed
Causes

- Compressor overload
- Compressor coil disconnected
- Defect of inverter PC board

Troubleshooting



Caution Be sure to turn off power switch before connect or disconnect connector, or parts damage may be occurred.

Output current check

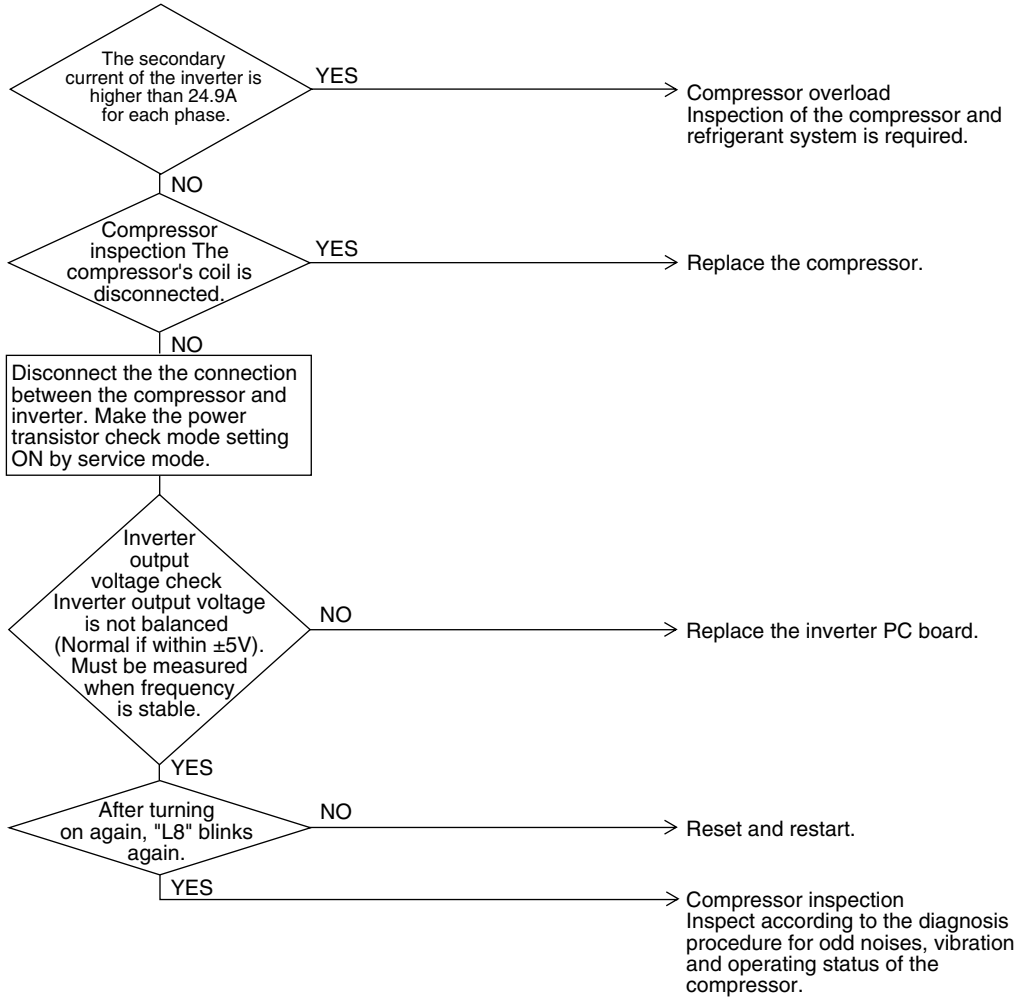

(V3184)

4.31 “L9” Outdoor Unit: Inverter Start up Error

Remote Controller Display

L9

Applicable Models

All outdoor unit models

Method of Malfunction Detection

Malfunction is detected from current flowing in the power transistor.

Malfunction Decision Conditions

When overload in the compressor is detected during startup.

Supposed Causes

- Defect of compressor
- Pressure differential start
- Defect of inverter PC board

Troubleshooting



Caution

Be sure to turn off power switch before connect or disconnect connector, or parts damage may be occurred.

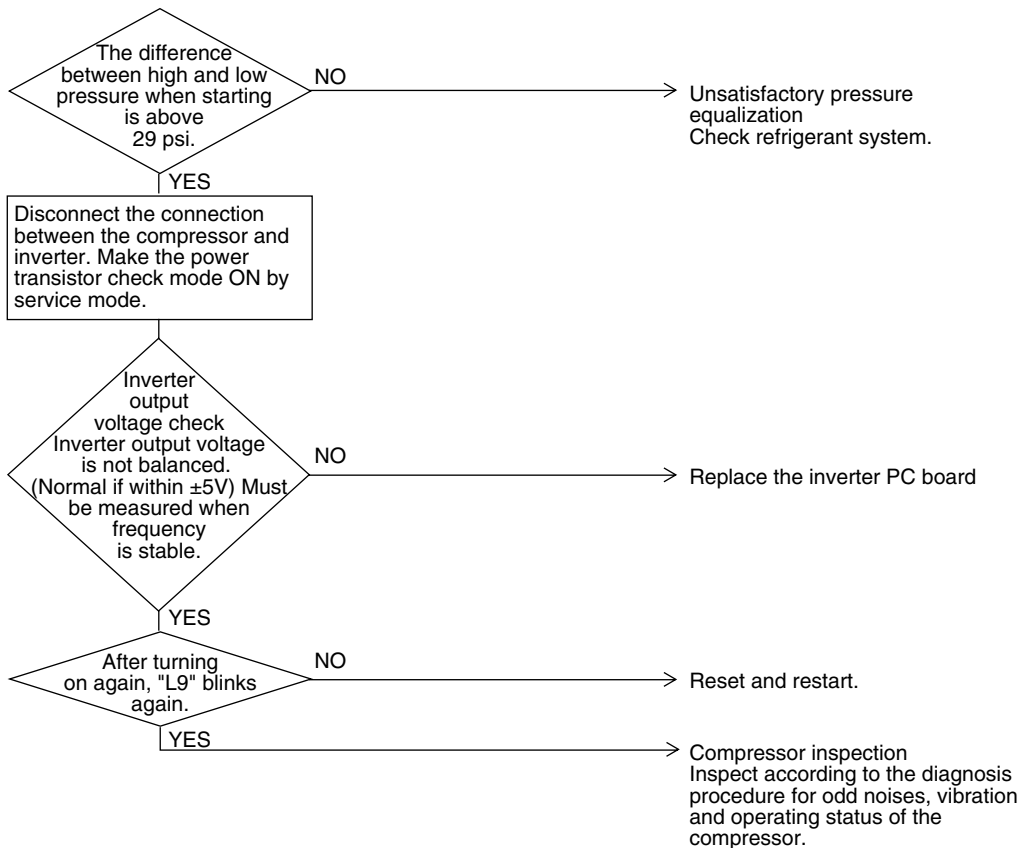

(V2814)

4.32 “LC” Outdoor Unit: Malfunction of Transmission between Inverter and Control PC Board

Remote Controller Display	LC
Applicable Models	All outdoor unit models
Method of Malfunction Detection	Check the communication state between inverter PC board and control PC board by micro-computer.
Malfunction Decision Conditions	When the correct communication is not conducted in certain period.
Supposed Causes	<ul style="list-style-type: none"> ■ Malfunction of connection between the inverter PC board and outdoor control PC board ■ Defect of outdoor control PC board (transmission section) ■ Defect of inverter PC board ■ Defect of noise filter ■ External factor (Noise etc.)

Troubleshooting



Caution Be sure to turn off power switch before connect or disconnect connector, or parts damage may be occurred.

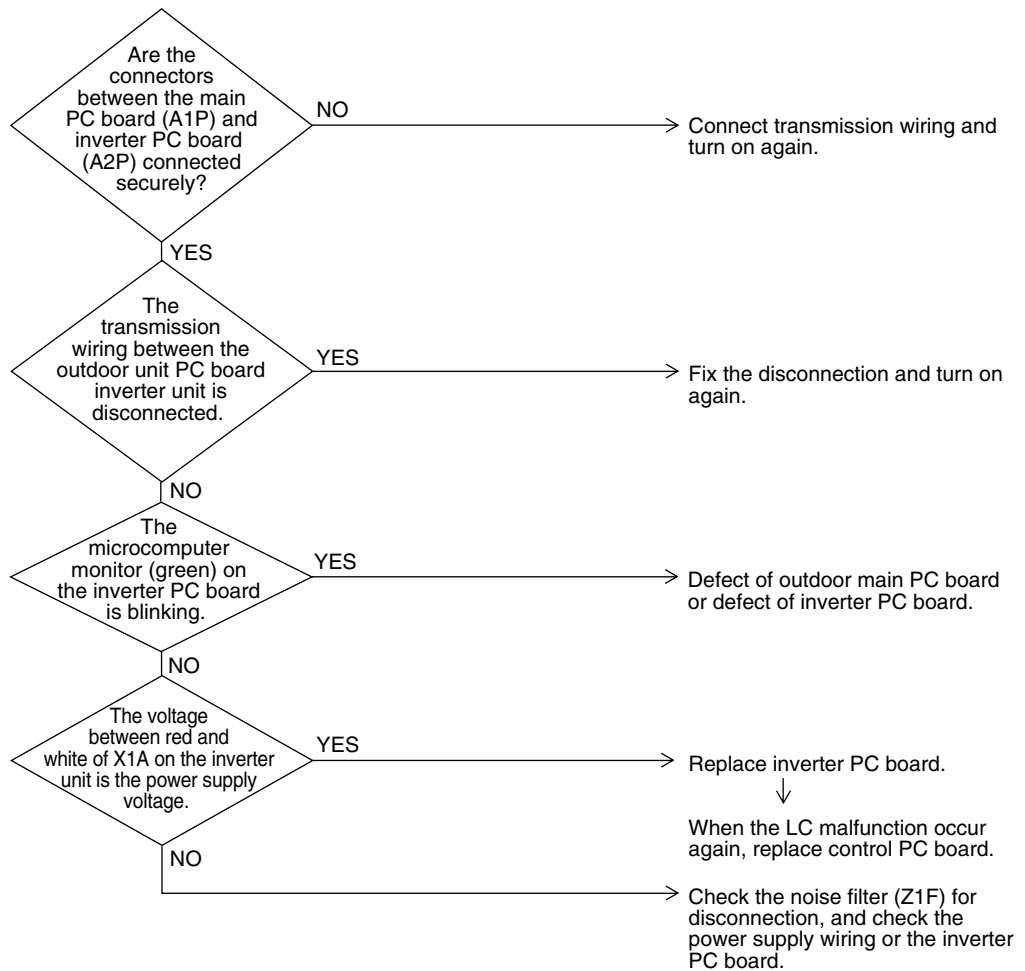

(V3185)

4.33 “P4” Outdoor Unit: Malfunction of Inverter Radiating Fin Temperature Rise Sensor

Remote Controller Display	<i>P4</i>
Applicable Models	All outdoor unit models
Method of Malfunction Detection	Resistance of radiation fin thermistor is detected when the compressor is not operating.
Malfunction Decision Conditions	<p>When the resistance value of thermistor becomes a value equivalent to open or short circuited status.</p> <ul style="list-style-type: none"> ■ Malfunction is not decided while the unit operation is continued. "P4" will be displayed by pressing the inspection button.
Supposed Causes	<ul style="list-style-type: none"> ■ Defect of radiator fin temperature sensor ■ Defect of inverter PC board

Troubleshooting



Caution

Be sure to turn off power switch before connect or disconnect connector, or parts damage may be occurred.

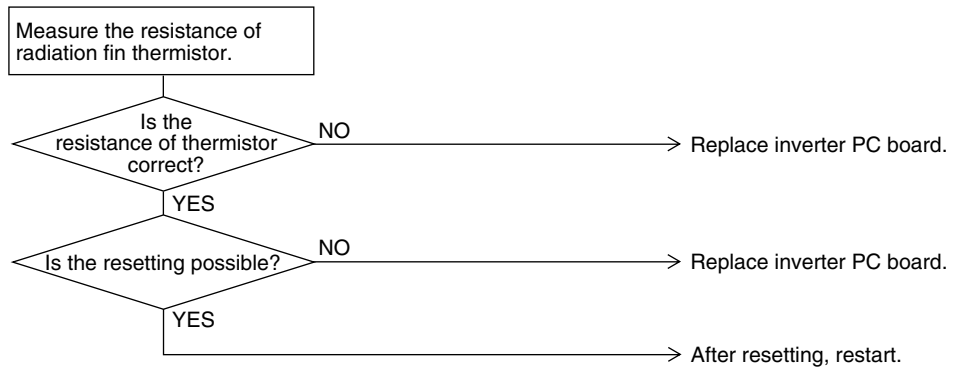

(V2818)



* Refer to “Thermistor Resistance / Temperature Characteristics” table on P190.

4.34 “PJ” Outdoor Unit: Faulty Combination of Inverter and Fan Driver

Remote Controller Display	PJ
Applicable Models	All outdoor unit models
Method of Malfunction Detection	Check the communication state between inverter PC board and control PC board by micro-computer.
Malfunction Decision Conditions	When the communication data about inverter PC board type is incorrect.
Supposed Causes	<ul style="list-style-type: none"> ■ Mismatching of inverter PC board ■ Faulty field setting

Troubleshooting



Caution

Be sure to turn off power switch before connect or disconnect connector, or parts damage may be occurred.

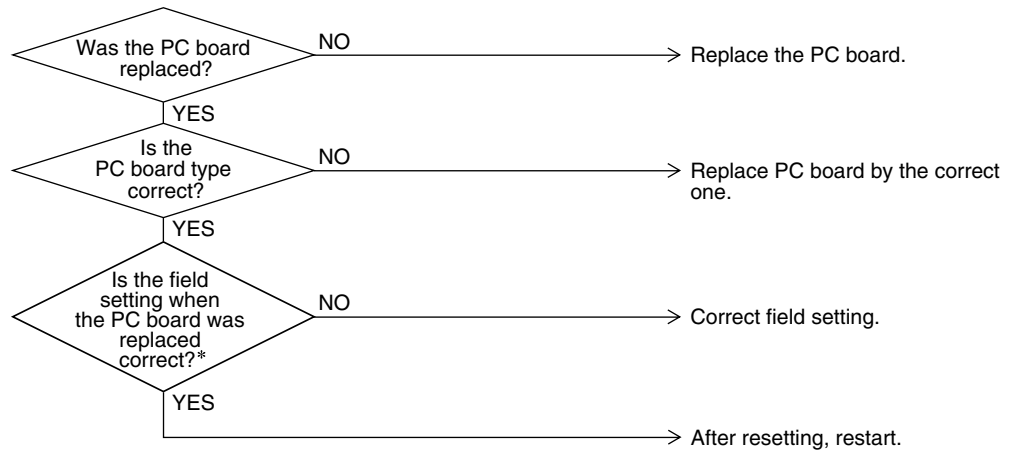

(V3151)



* Refer to “Field Setting from Outdoor Unit” on P70.

4.35 “UO” Outdoor Unit: Low Pressure Drop Due to Refrigerant Shortage or Electronic Expansion Valve Failure

Remote Controller Display

UO

Applicable Models

All outdoor unit models

Method of Malfunction Detection

Short of gas malfunction is detected by discharge pipe temperature thermistor.

Malfunction Decision Conditions

Microcomputer judge and detect if the system is short of refrigerant.
 ★Malfunction is not decided while the unit operation is continued.

Supposed Causes

- Out of gas or refrigerant system clogging (incorrect piping)
- Defect of thermistor R2T or R4T
- Defect of pressure sensor
- Defect of outdoor unit PC board (A1P)

Troubleshooting



Caution

Be sure to turn off power switch before connect or disconnect connector, or parts damage may be occurred.

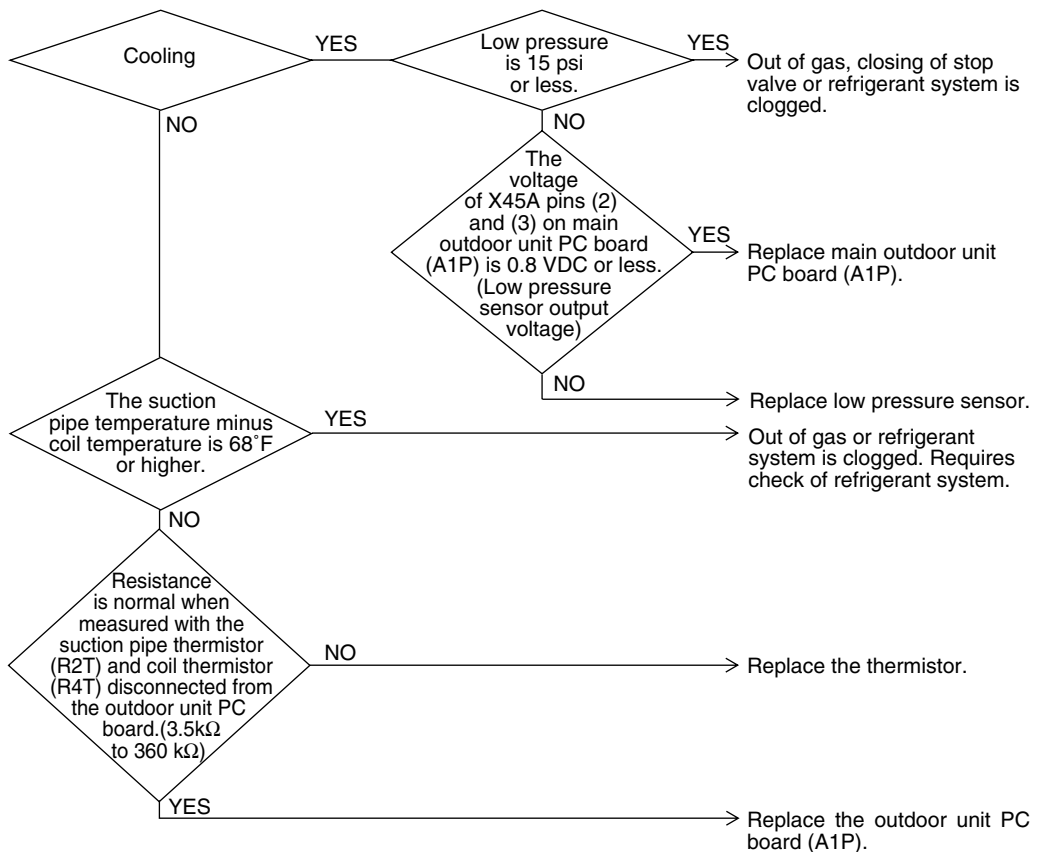

(V2819)

4.36 “U2” Outdoor Unit: Power Supply Insufficient or Instantaneous Failure

Remote Controller Display	U2
Applicable Models	All outdoor unit models
Method of Malfunction Detection	Detection of voltage of main circuit capacitor built in the inverter and power supply voltage.
Malfunction Decision Conditions	When the capacitor above only has a voltage of 190 V or less.
Supposed Causes	<ul style="list-style-type: none"> ■ Power supply insufficient ■ Instantaneous failure ■ Defect of inverter PC board ■ Defect of outdoor control PC board ■ Main circuit wiring defect

Troubleshooting



Caution

Be sure to turn off power switch before connect or disconnect connector, or parts damage may be occurred.

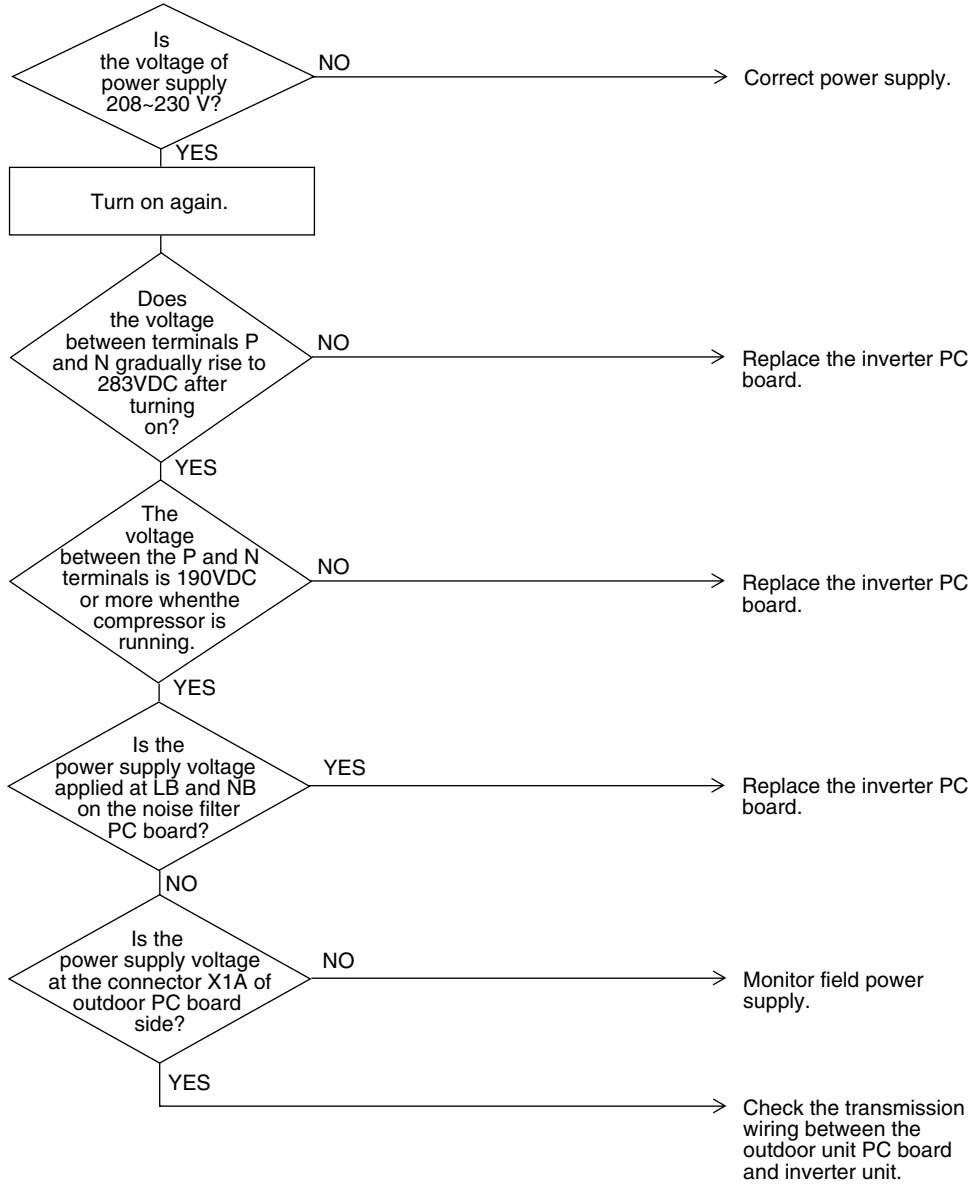

(V3186)

4.37 “U3” Outdoor Unit: Check Operation not Executed

Remote
Controller
Display

U3

Applicable
Models

All outdoor unit models

Method of
Malfunction
Detection

Check operation is executed or not

Malfunction
Decision
Conditions

Malfunction is decided when the unit starts operation without check operation.

Supposed
Causes

- Check operation is not executed.

Troubleshooting



Caution

Be sure to turn off power switch before connect or disconnect connector, or parts damage may be occurred.

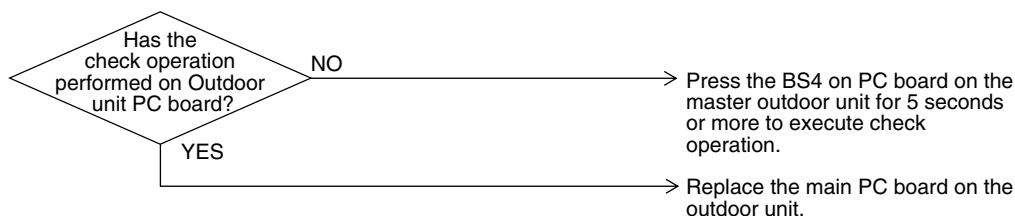

(V3052)

4.38 “U4” Malfunction of Transmission between Indoor Units and Outdoor Units

Remote Controller Display	U4
Applicable Models	All indoor unit models All outdoor unit models
Method of Malfunction Detection	Microcomputer checks if transmission between indoor and outdoor units is normal.
Malfunction Decision Conditions	When transmission is not carried out normally for a certain amount of time
Supposed Causes	<ul style="list-style-type: none"> ■ Indoor to outdoor, outdoor to outdoor transmission wiring F1, F2 disconnection, short circuit or wrong wiring ■ Outdoor unit power supply is OFF ■ System address doesn't match ■ Defect of outdoor unit PC board ■ Defect of indoor unit PC board

Troubleshooting



Caution Be sure to turn off power switch before connect or disconnect connector, or parts damage may be occurred.

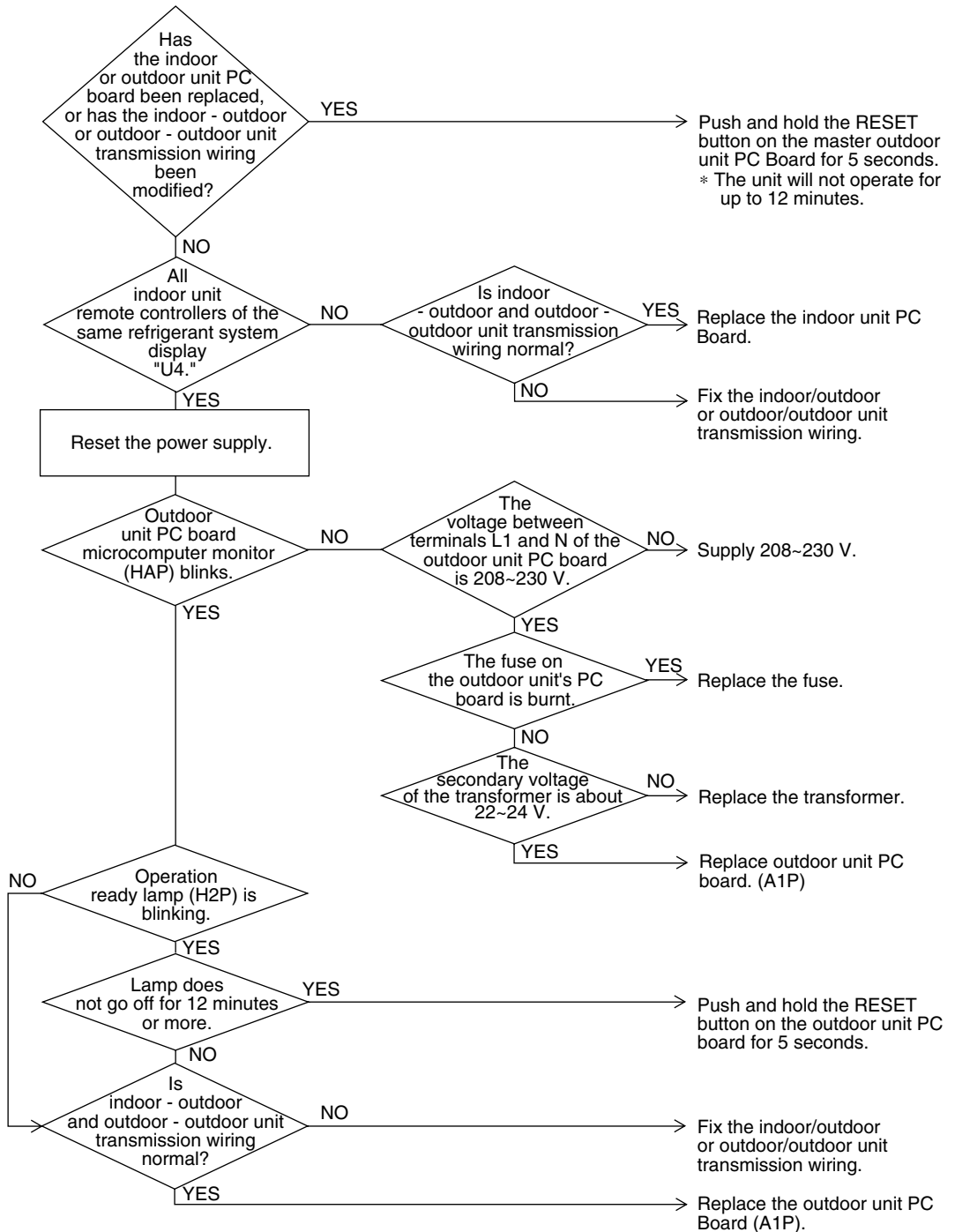

(V3187)

4.39 “U5” Indoor Unit: Malfunction of Transmission between Remote Controller and Indoor Unit

Remote Controller Display	U5
Applicable Models	All indoor unit models
Method of Malfunction Detection	In case of controlling with 2-remote controller, check the system using microcomputer is signal transmission between indoor unit and remote controller (main and sub) is normal.
Malfunction Decision Conditions	Normal transmission does not continue for specified period.
Supposed Causes	<ul style="list-style-type: none"> ■ Malfunction of indoor unit remote controller transmission ■ Connection of two main remote controllers (when using 2 remote controllers) ■ Defect of indoor unit PC board ■ Defect of remote controller PC board ■ Malfunction of transmission caused by noise

Troubleshooting

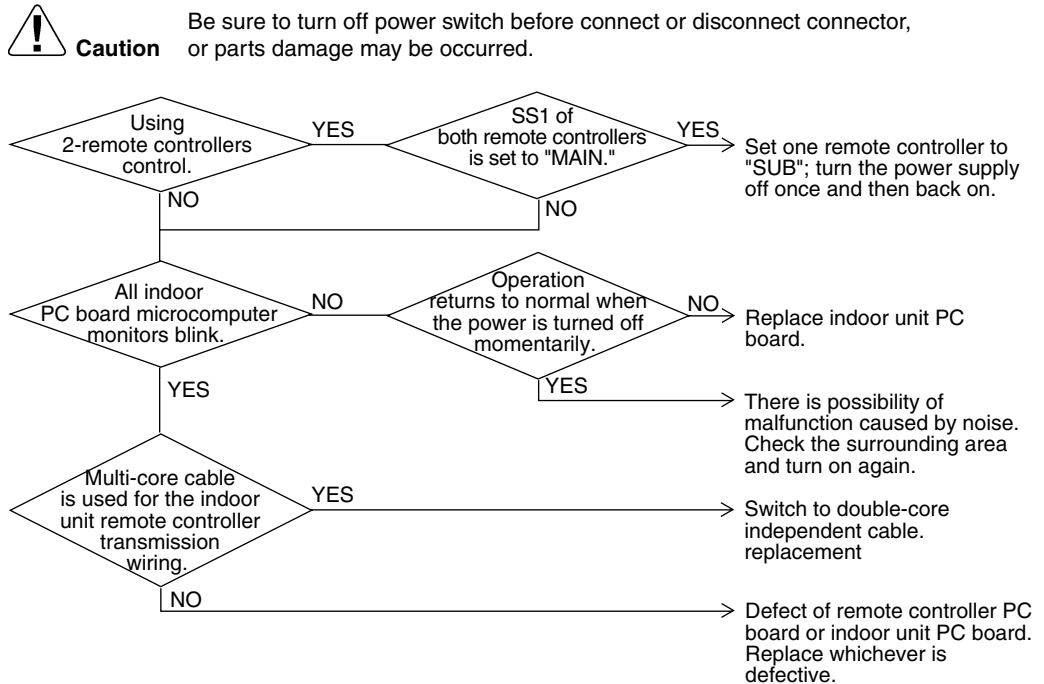

(V2823)

4.40 “UB” Indoor Unit: Malfunction of Transmission between Main and Sub Remote Controllers

Remote Controller Display

UB

Applicable Models

All indoor unit models

Method of Malfunction Detection

In case of controlling with 2-remote controller, check the system using microcomputer if signal transmission between indoor unit and remote controller (main and sub) is normal.

Malfunction Decision Conditions

Normal transmission does not continue for specified period.

Supposed Causes

- Malfunction of transmission between main and sub remote controller
- Connection between sub remote controllers
- Defect of remote controller PC board

Troubleshooting



Caution

Be sure to turn off power switch before connect or disconnect connector, or parts damage may be occurred.

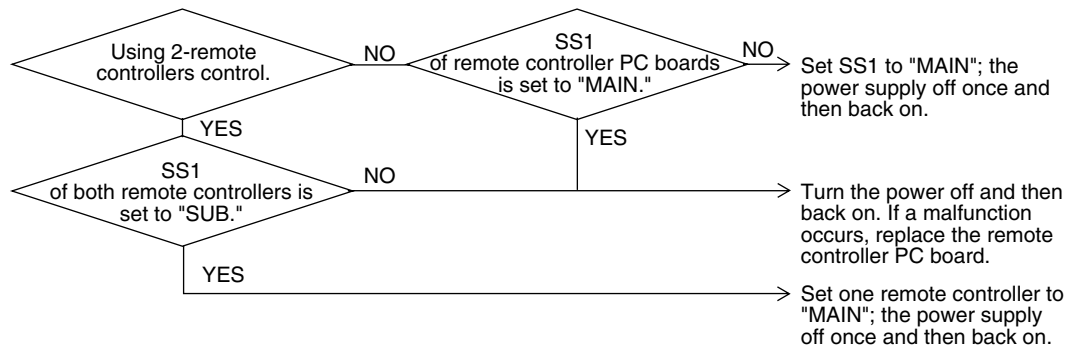

(V2825)

4.41 “U9” Indoor Unit: Malfunction of Transmission between Indoor Units and Outdoor Units in the Same System

Remote Controller Display	U9
Applicable Models	All indoor unit models
Method of Malfunction Detection	Detect the malfunction signal of any other indoor unit within the system concerned.
Malfunction Decision Conditions	When the malfunction decision is made on any other indoor unit within the system concerned.
Supposed Causes	<ul style="list-style-type: none"> ■ Malfunction of transmission within or outside of other system ■ Malfunction of electronic expansion valve in indoor unit of other system ■ Defect of PC board of indoor unit in other system ■ Improper connection of transmission wiring between indoor and outdoor unit

Troubleshooting



Caution

Be sure to turn off power switch before connect or disconnect connector, or parts damage may be occurred.

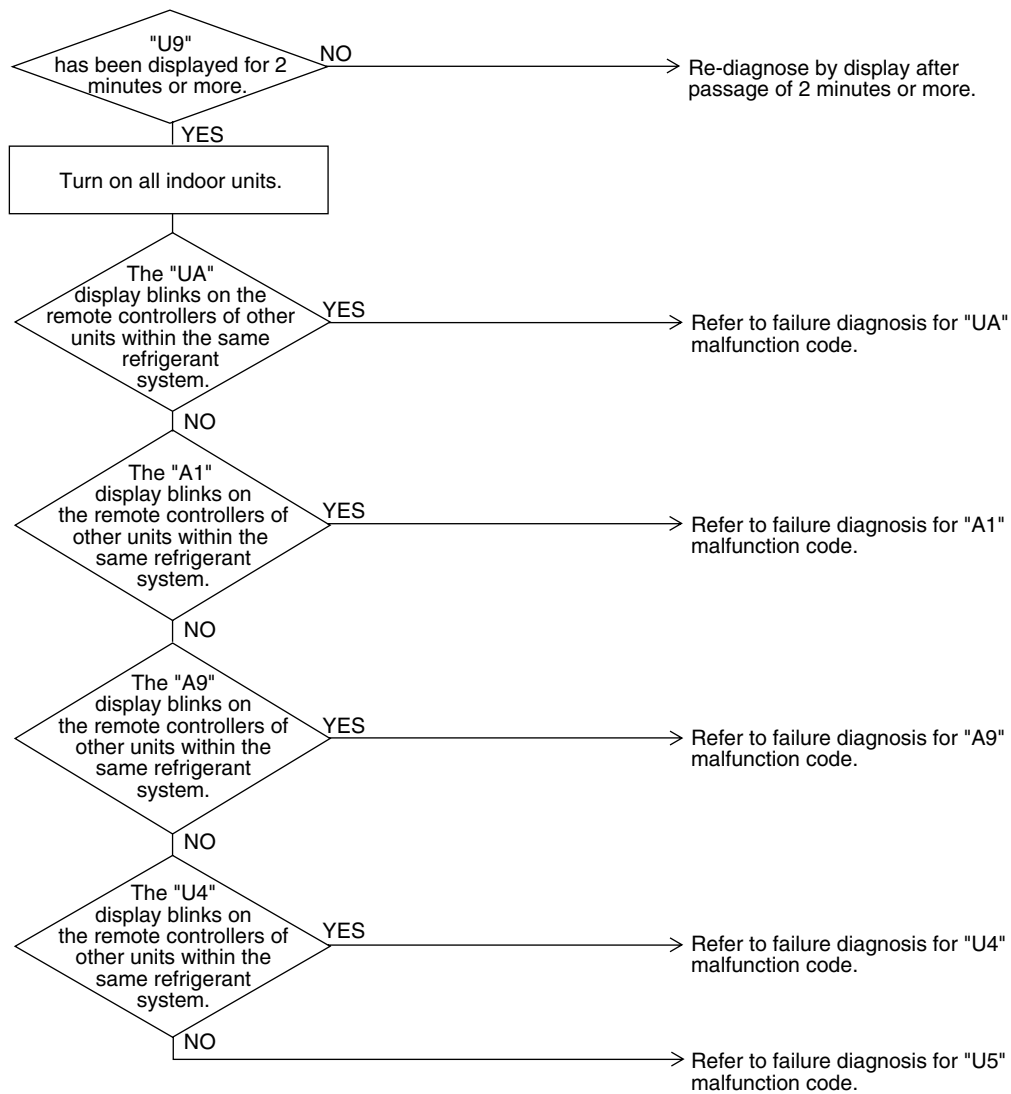

(V2826)

4.42 “UR” Improper Combination of Indoor Units and Outdoor Units, Indoor Units and Remote Controller

Remote Controller Display	<i>UR</i>
Applicable Models	All indoor unit models All outdoor unit models Remote controller
Method of Malfunction Detection	A difference occurs in data by the type of refrigerant between indoor and outdoor units. The number of indoor units is outside of the allowable range.
Malfunction Decision Conditions	The malfunction decision is made as soon as either of the abnormalities abovementioned is detected.
Supposed Causes	<ul style="list-style-type: none"> ■ Excess of connected indoor units ■ Defect of outdoor unit PC board (A1P) ■ Mismatching of the refrigerant type of indoor and outdoor unit. ■ Setting of outdoor P.C. board was not conducted after replacing to spare parts P.C. board.

Troubleshooting



Caution

Be sure to turn off power switch before connect or disconnect connector, or parts damage may be occurred.

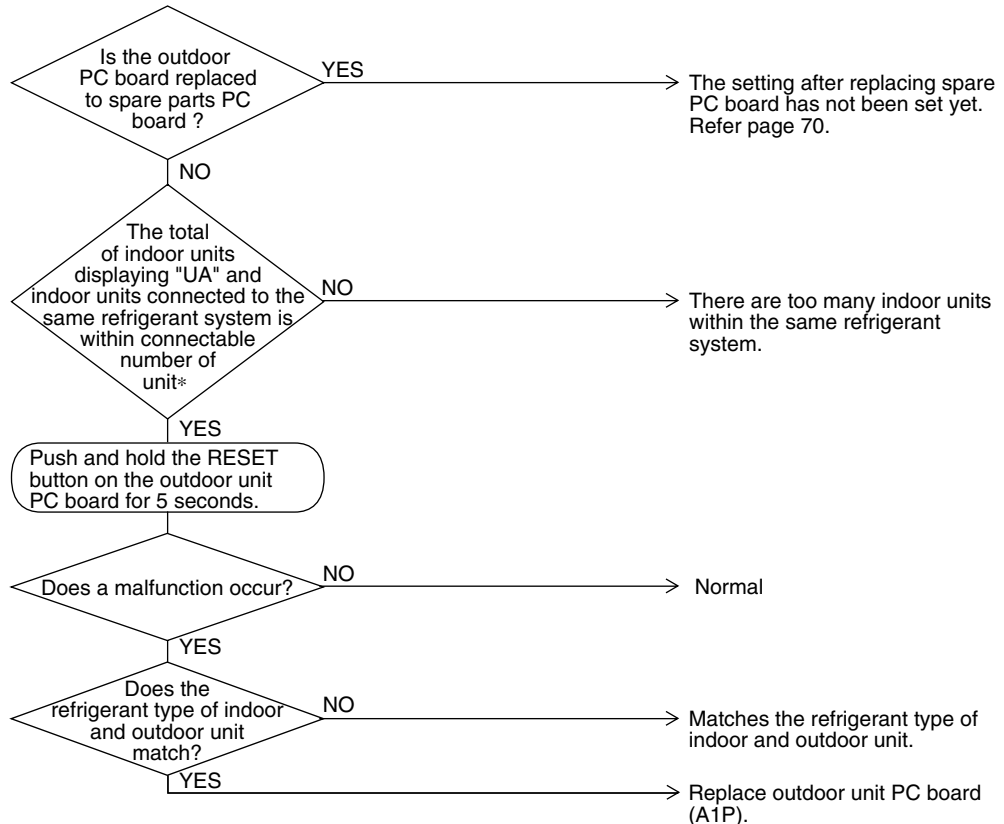

(V3169)

* The number of indoor units that can be connected to a single outdoor unit system depends on the type of outdoor unit.

4.43 “UC” Address Duplication of Central Remote Controller

Remote
Controller
Display

UC

Applicable
Models

All indoor unit models
Central remote controller

Method of
Malfunction
Detection

The principal indoor unit detects the same address as that of its own on any other indoor unit.

Malfunction
Decision
Conditions

The malfunction decision is made as soon as the abnormality abovementioned is detected.

Supposed
Causes

- Address duplication of centralized remote controller
- Defect of indoor unit PC board

Troubleshooting



Caution

Be sure to turn off power switch before connect or disconnect connector, or parts damage may be occurred.

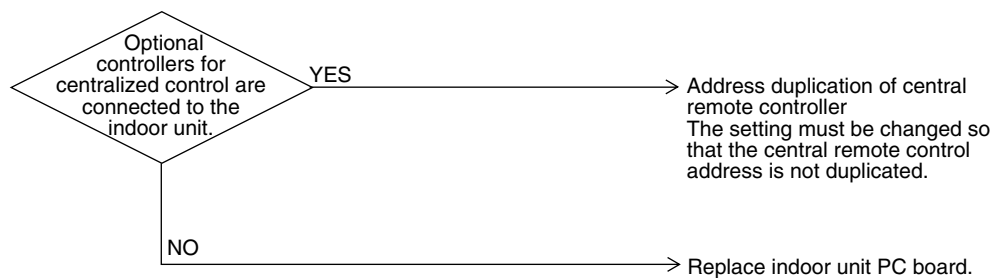

(V2828)

4.44 “UE” Malfunction of Transmission between Central Remote Controller and Indoor Unit

Remote Controller Display	UE
Applicable Models	All indoor unit models Central remote controller
Method of Malfunction Detection	Microcomputer checks if transmission between indoor unit and central remote controller is normal.
Malfunction Decision Conditions	When transmission is not carried out normally for a certain amount of time
Supposed Causes	<ul style="list-style-type: none"> ■ Malfunction of transmission between optional controllers for centralized control and indoor unit ■ Connector for setting master controller is disconnected. ■ Failure of PC board for central remote controller ■ Defect of indoor unit PC board

Troubleshooting



Caution Be sure to turn off power switch before connect or disconnect connector, or parts damage may be occurred.

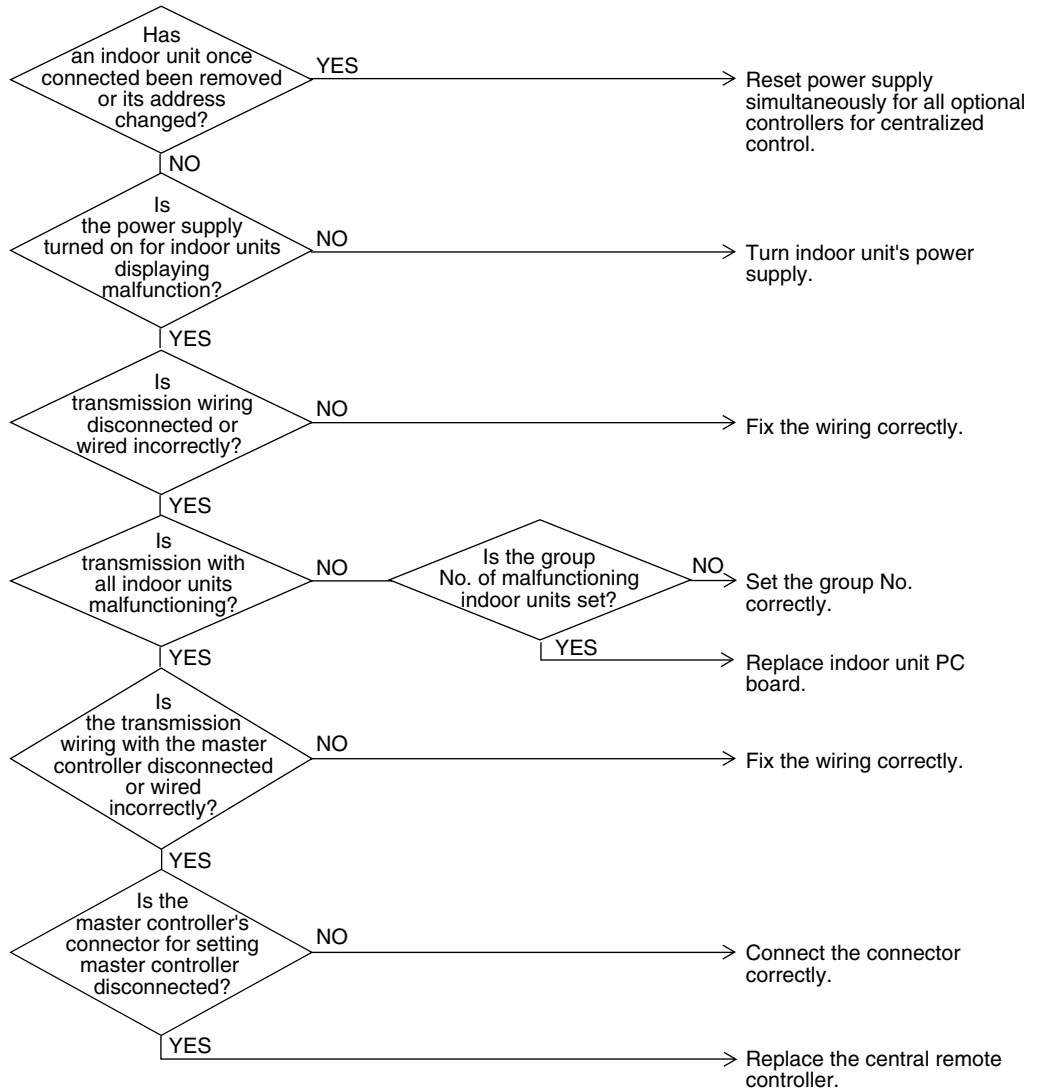

(V2829)

4.45 “UF” System not Set yet

Remote
Controller
Display

UF

Applicable
Models

All indoor unit models
All outdoor unit models

Method of
Malfunction
Detection

The number of indoor units in terms of data transmission becomes mismatched to that of indoor units with changes in temperature on operation for checks.

Malfunction
Decision
Conditions

The malfunction is determined as soon as the abnormality aforementioned is detected through checking the system for any erroneous connection of units on the check operation.

Supposed
Causes

- Improper connection of transmission wiring between indoor-outdoor units and outdoor-outdoor units.
- Failure to execute check operation
- Defect of indoor unit PC board
- Failure to open the stop valve

Troubleshooting



Caution

Be sure to turn off power switch before connect or disconnect connector, or parts damage may be occurred.

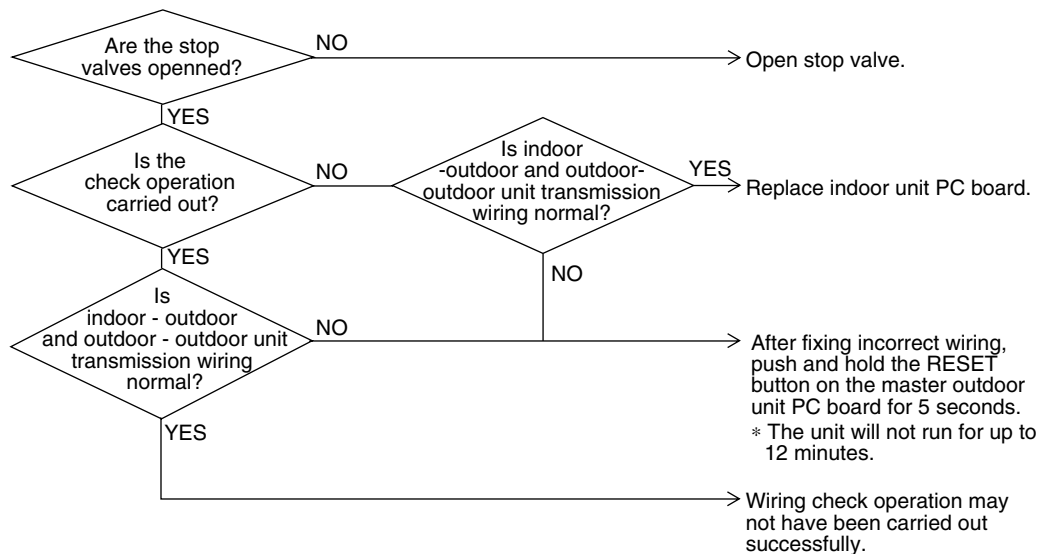

(V2830)



Note: Wiring check operation may not be successful if carried out after the outdoor unit has been off for more than 12 hours, or if it is not carried out after running all connected indoor units in the fan mode for at least an hour.

4.46 “UH” Malfunction of System, Refrigerant System Address Undefined

Remote Controller Display

UH

Applicable Models

All indoor unit models
All outdoor unit models

Method of Malfunction Detection

Detect an indoor unit with no address setting.

Malfunction Decision Conditions

The malfunction decision is made as soon as the abnormality abovementioned is detected.

Supposed Causes

- Improper connection of transmission wiring between indoor-outdoor units and outdoor-outdoor units.
- Defect of indoor unit PC board
- Defect of outdoor unit PC board (A1P)

Troubleshooting



Caution

Be sure to turn off power switch before connect or disconnect connector, or parts damage may be occurred.

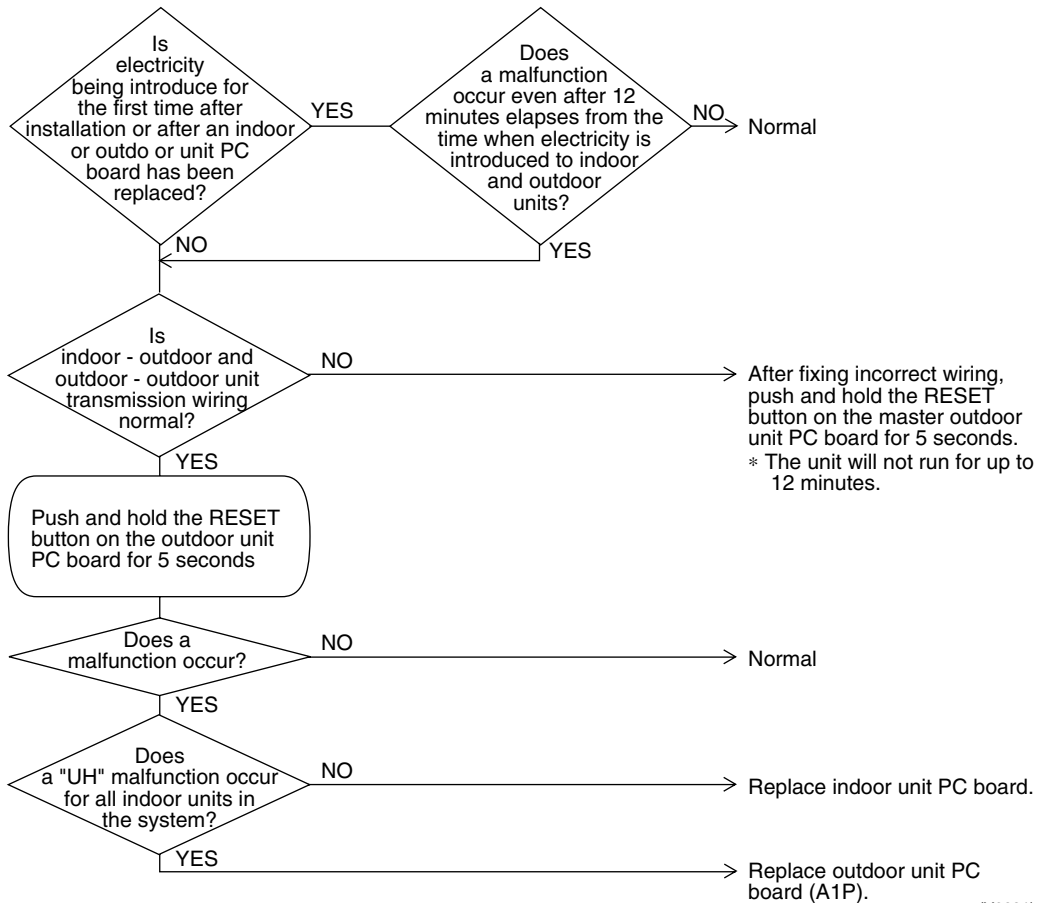

(V2831)

5. Troubleshooting by Indication on the Central Remote Controller

5.1 “UE” Malfunction of Transmission between Central Remote Controller and Indoor Unit

Remote Controller
Display

UE

Applicable
Models

All indoor unit models
Central Remote Controller

Method of
Malfunction
Detection

Microcomputer checks if transmission between indoor unit and central remote controller is normal.

Malfunction
Decision
Conditions

When transmission is not carried out normally for a certain amount of time

Supposed
Causes

- Malfunction of transmission between central remote controller and indoor unit
- Connector for setting master controller is disconnected.
- Failure of PC board for central remote controller
- Defect of indoor unit PC board

Troubleshooting



Caution

Be sure to turn off power switch before connect or disconnect connector, or parts damage may be occurred.

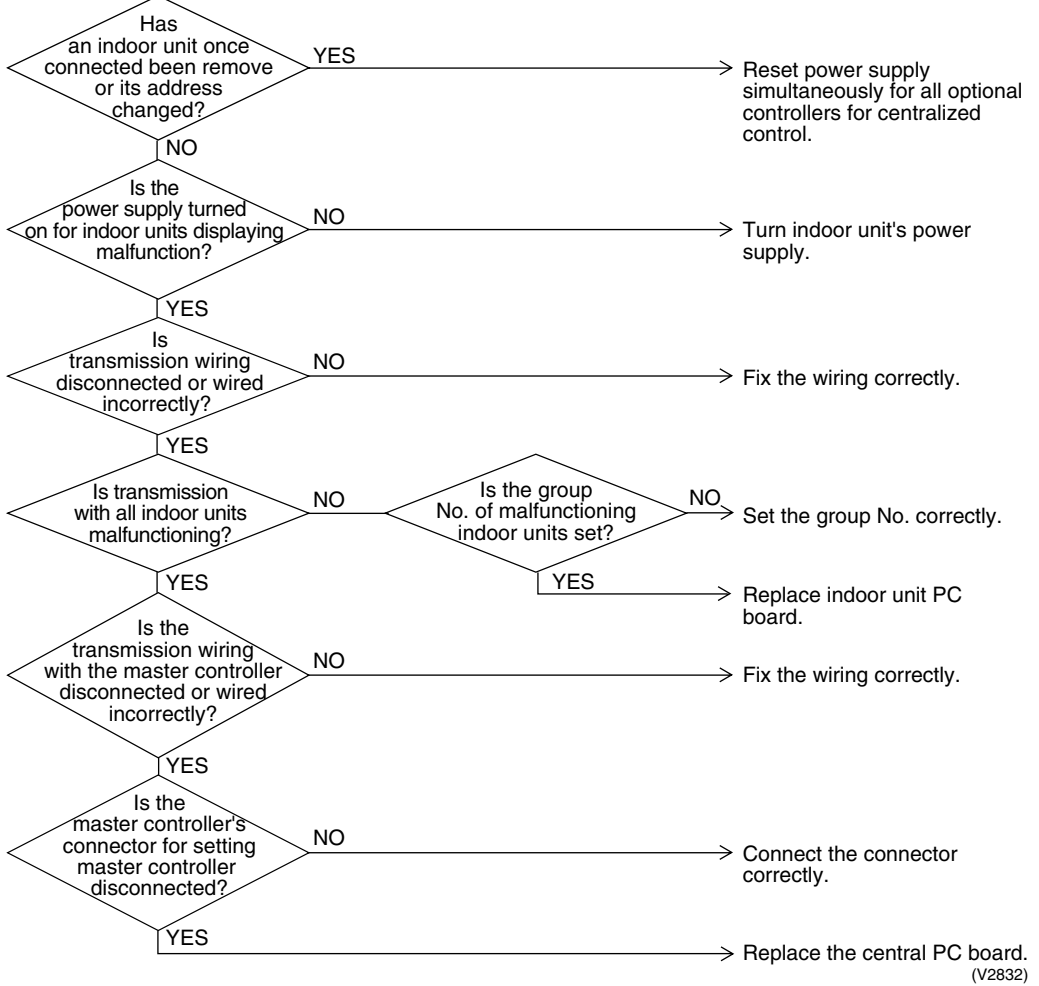

(V2832)

5.2 “M” PC Board Defect

Remote
Controller
Display

M

Applicable
Models

Central remote controller

Method of
Malfunction
Detection

Detect an abnormality in the DIII-NET polarity circuit.

Malfunction
Decision
Conditions

When + polarity and - polarity are detected at the same time.

Supposed
Causes

- Defect of central remote controller PC board

Troubleshooting

Replace the central remote controller.

5.3 “M8” Malfunction of Transmission between Optional Controllers for Centralized Control

Remote Controller Display

M8

Applicable Models

Central remote controller

Method of Malfunction Detection

Detect the malfunction according to DIII-NET transmission data. (The system will be automatically reset.)

Malfunction Decision Conditions

When no master controller is present at the time of the startup of slave controller.
When optional controllers for the centralized control which was connected once, shows no response.

Supposed Causes

- Malfunction of transmission between optional controllers for centralized control
- Defect of PC board of optional controllers for centralized control

Troubleshooting



Caution

Be sure to turn off power switch before connect or disconnect connector, or parts damage may be occurred.

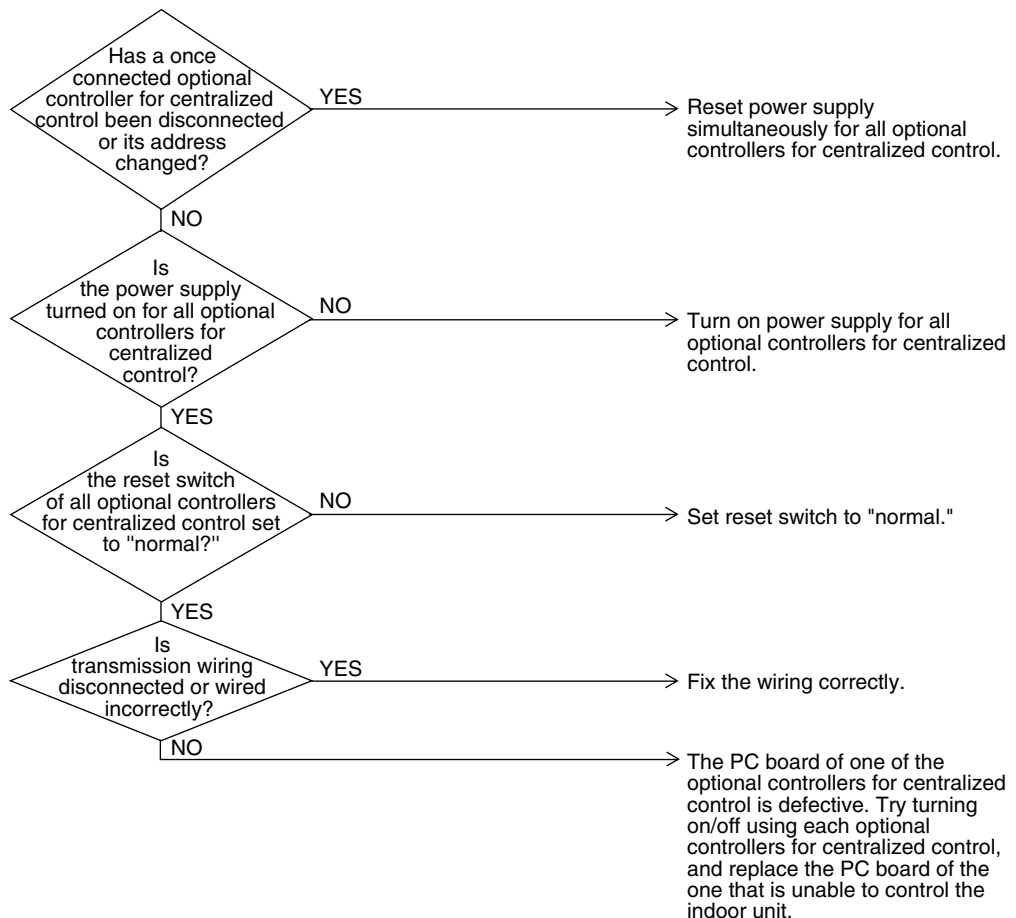

(V2833)

5.4 “MR” Improper Combination of Optional Controllers for Centralized Control

Remote Controller Display	MR
Applicable Models	Central remote controller
Method of Malfunction Detection	Detect the malfunction according to DIII-NET transmission data.
Malfunction Decision Conditions	When the schedule timer is set to individual use mode, other central component is present. When multiple master controller are present. When the remote control adapter is present.
Supposed Causes	<ul style="list-style-type: none"> ■ Improper combination of optional controllers for centralized control ■ More than one master controller is connected ■ Defect of PC board of optional controller for centralized control

Troubleshooting



Caution Be sure to turn off power switch before connect or disconnect connector, or parts damage may be occurred.

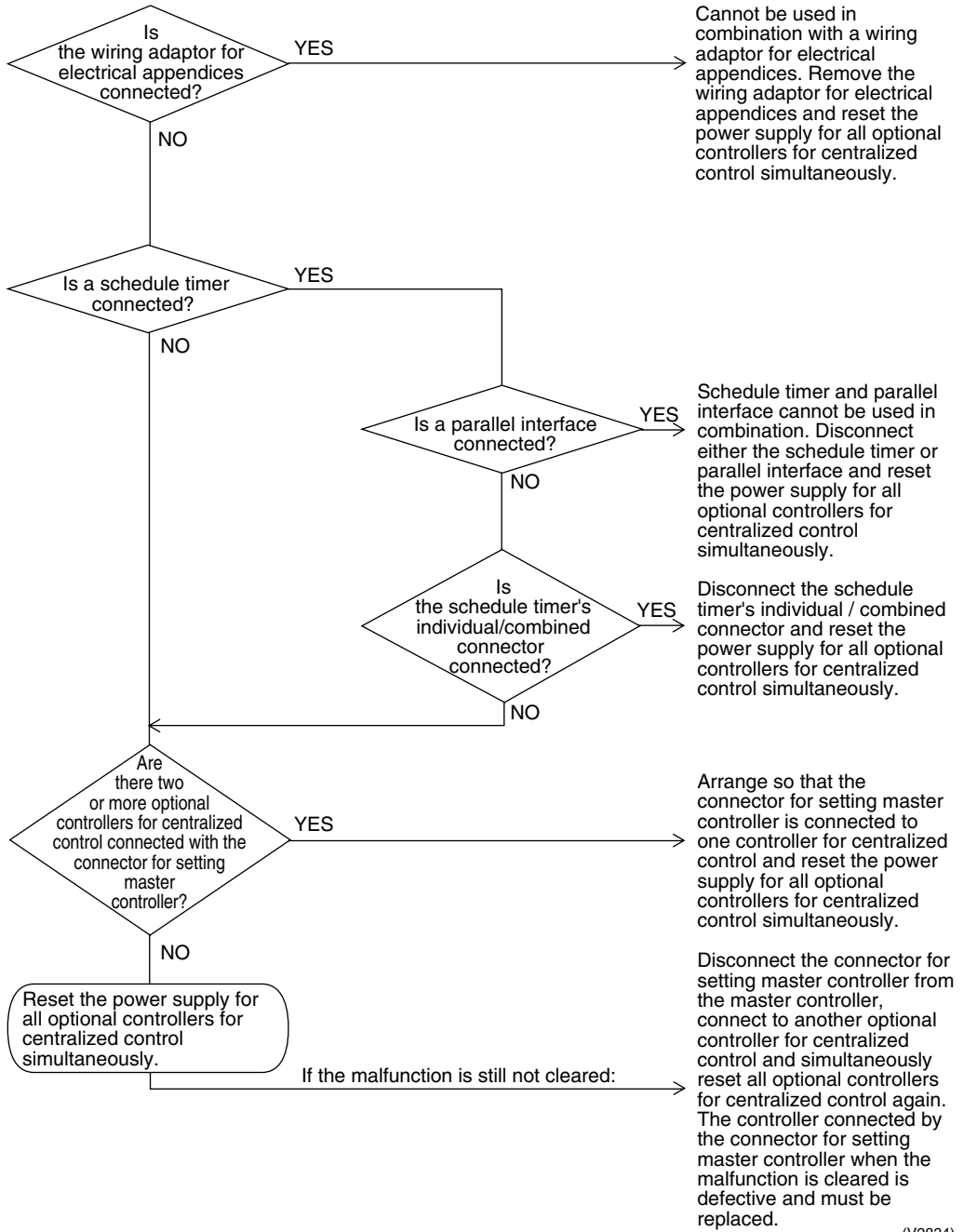

(V2834)

5.5 “MC” Address Duplication, Improper Setting

Remote
Controller
Display

MC

Applicable
Models

Central remote controller

Method of
Malfunction
Detection

Detect the malfunction according to DIII-NET transmission data.

Malfunction
Decision
Conditions

Two units are both set to master controller mode or slave controller mode.

Supposed
Causes

- Address duplication of central remote controller

Troubleshooting



Caution

Be sure to turn off power switch before connect or disconnect connector, or parts damage may be occurred.

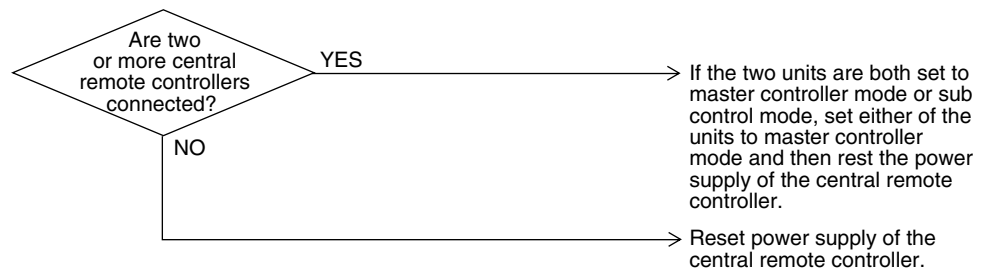

(V2835)

6. Troubleshooting by Indication on the Unified ON/OFF Controller

6.1 Operation Lamp Blinks

Remote Controller Display	Operation lamp blinks
Applicable Models	All models of indoor units Unified ON/OFF controller
Method of Malfunction Detection	Detect the malfunction according to DIII-NET transmission data.
Malfunction Decision Conditions	
Supposed Causes	<ul style="list-style-type: none">■ Malfunction of transmission between central remote controller and indoor unit■ Connector for setting master controller is disconnected■ Defect of unified ON/OFF controller■ Defect of indoor unit PC board■ Malfunction of air conditioner

Troubleshooting



Caution

Be sure to turn off power switch before connect or disconnect connector, or parts damage may be occurred.

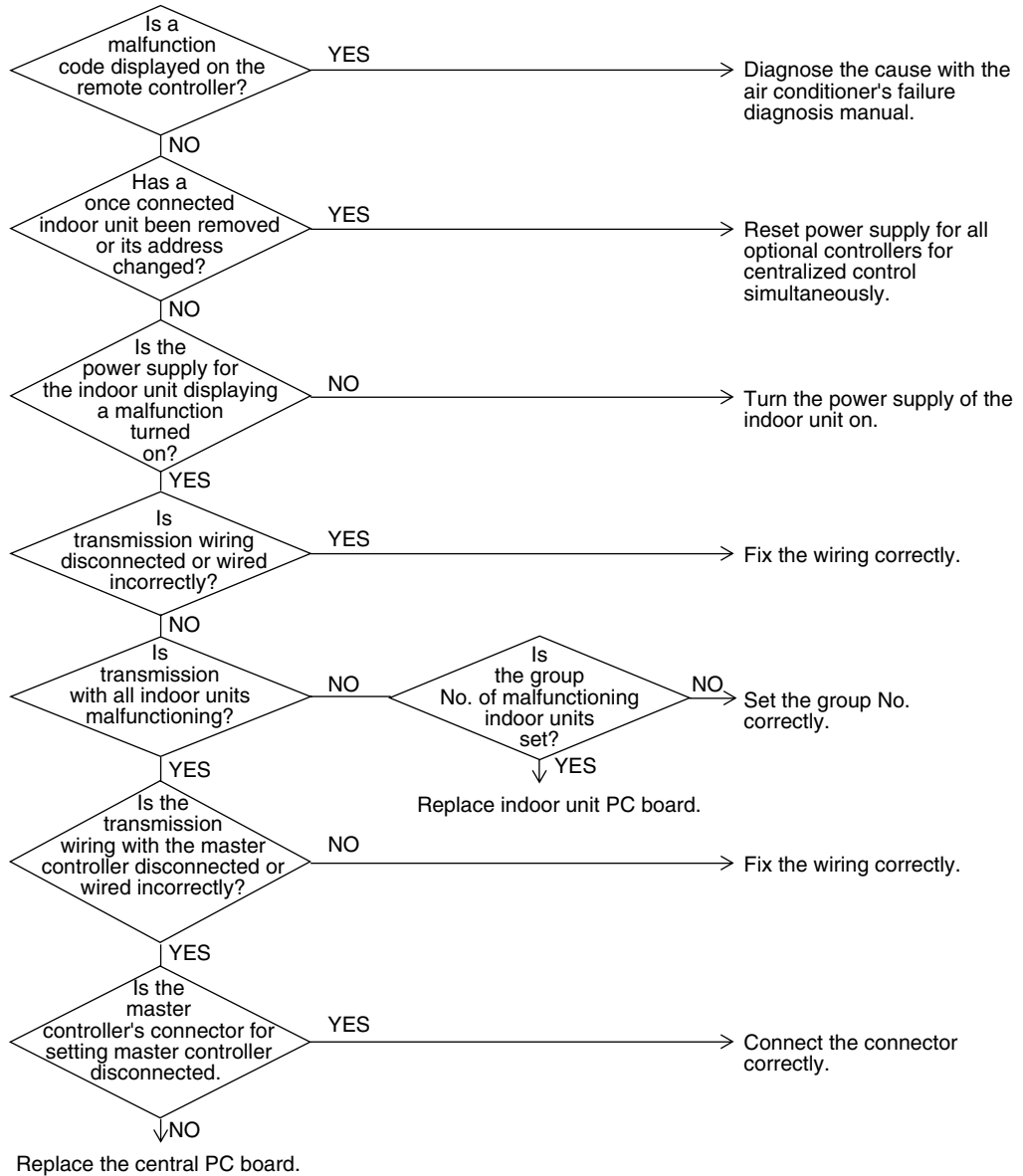

(V2841)

6.2 Display “Under Centralized Control” Blinks (Repeats Single Blink)

Remote Controller Display	 “under centralized control” (Repeats single blink)
Applicable Models	Unified ON/OFF controller Central remote controller Schedule timer
Method of Malfunction Detection	Detect the malfunction according to DIII-NET transmission data.
Malfunction Decision Conditions	When the centralized controller, which was connected once, shows no response. The control ranges are overlapped. When multiple master central controller are present.
Malfunction Decision Conditions	When the schedule timer is set to individual use mode, other central controller is present. When the wiring adaptor for electrical appendices is present.
Supposed Causes	<ul style="list-style-type: none"> ■ Address duplication of central remote controller ■ Improper combination of optional controllers for centralized control ■ Connection of more than one master controller ■ Malfunction of transmission between optional controllers for centralized control ■ Defect of PC board of optional controllers for centralized control

Troubleshooting



Caution

Be sure to turn off power switch before connect or disconnect connector, or parts damage may be occurred.

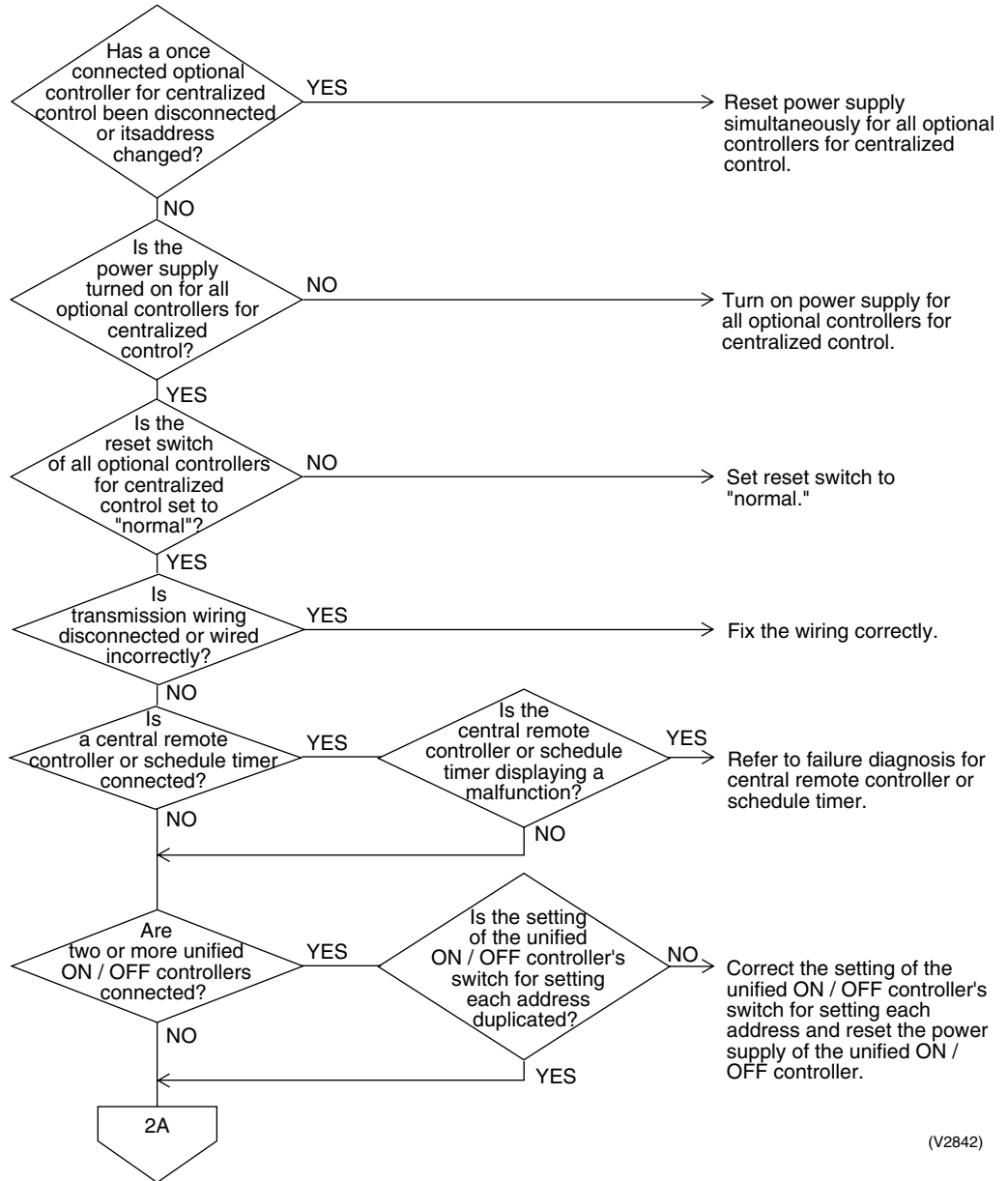

(V2842)

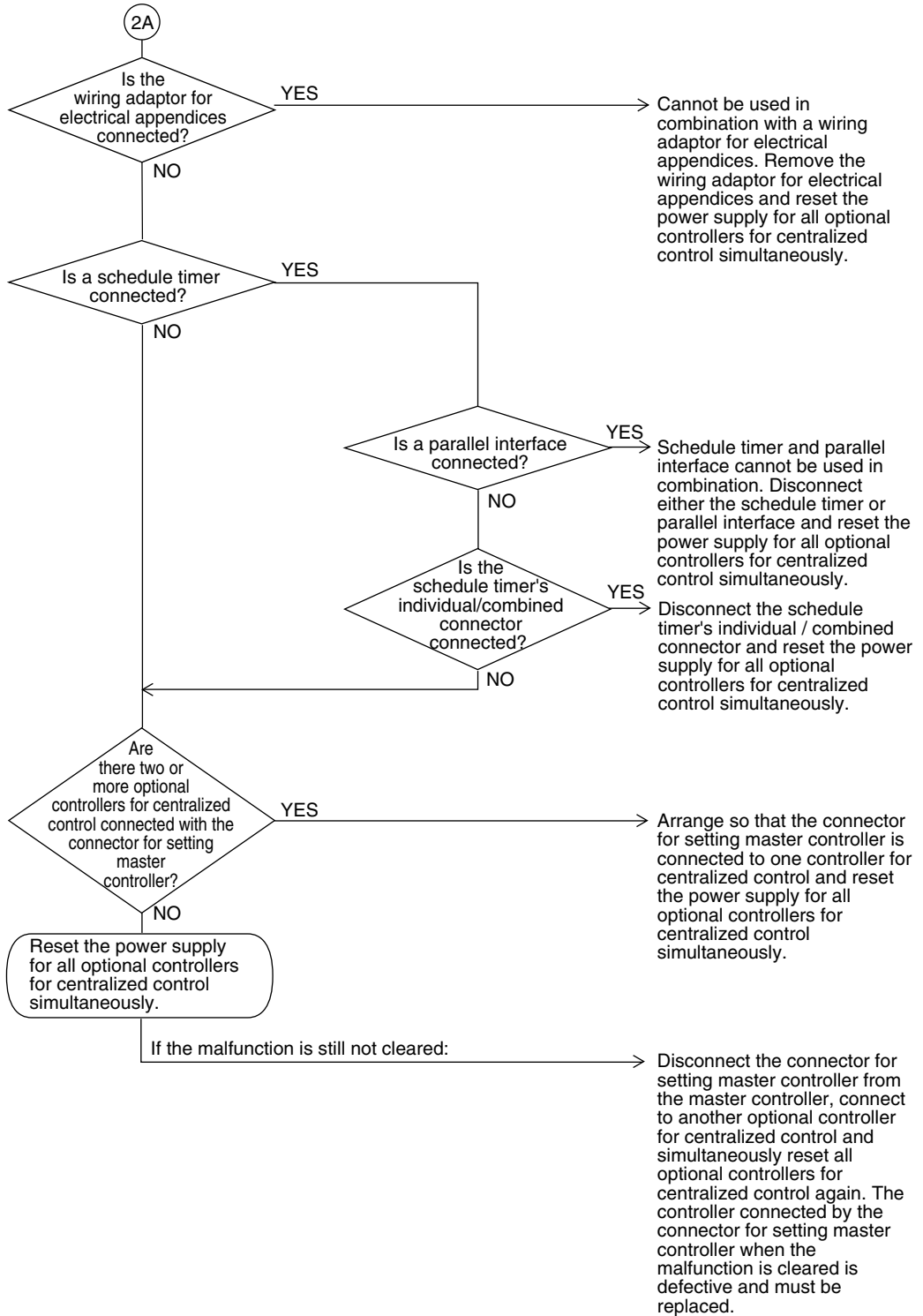

(V2843)

6.3 Display “Under Centralized Control” Blinks (Repeats Double Blink)

Remote Controller Display

 “under centralized control” (Repeats double blink)

Applicable Models

Unified ON/OFF controller

Method of Malfunction Detection

Detect the malfunction according to DIII-NET transmission data.

Malfunction Decision Conditions

When no central control addresses are set to indoor units.
When no indoor units are connected within the control range.

Supposed Causes

- Central control address (group No.) is not set for indoor unit.
- Improper control range setting switch
- Improper wiring of transmission wiring

Troubleshooting



Caution

Be sure to turn off power switch before connect or disconnect connector, or parts damage may be occurred.

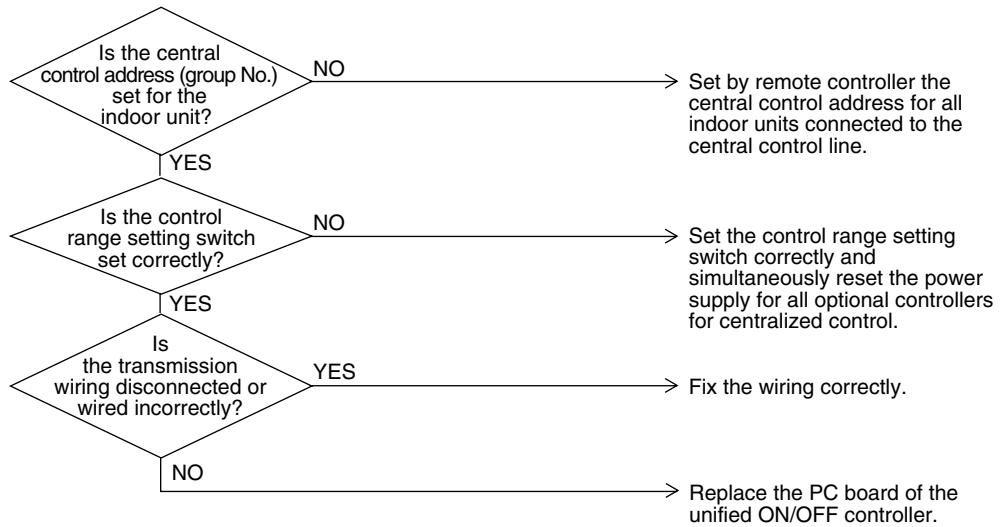

(V2844)

7. Troubleshooting (OP: Schedule Timer)

7.1 “UE” Malfunction of Transmission between Central Remote Controller and Indoor Unit

Remote Controller Display	<i>UE</i>
Applicable Models	Schedule timer All models of indoor units
Method of Malfunction Detection	Microcomputer checks if transmission between indoor unit and central remote controller is normal.
Malfunction Decision Conditions	When transmission is not carried out normally for a certain amount of time
Supposed Causes	<ul style="list-style-type: none"> ■ Malfunction of transmission between central remote controller and indoor unit ■ Disconnection of connector for setting master controller (or individual/combined switching connector) ■ Defect of schedule timer PC board ■ Defect of indoor unit PC board

Troubleshooting

 **Caution** Be sure to turn off power switch before connect or disconnect connector, or parts damage may be occurred.

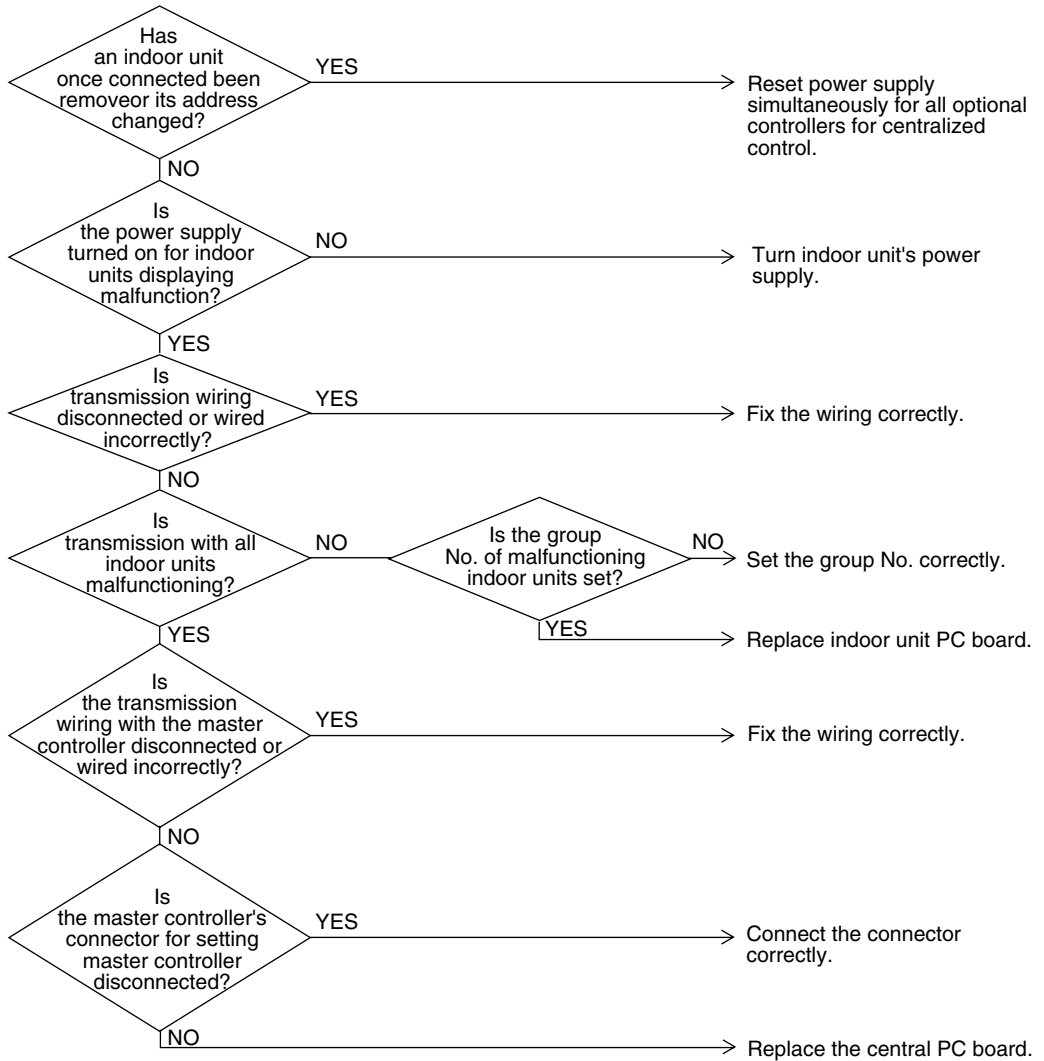

(V2836)

7.2 “M” PC Board Defect

Remote
Controller
Display

M

Applicable
Models

Schedule timer

Method of
Malfunction
Detection

Detect an abnormality in the DIII-NET polarity circuit.

Malfunction
Decision
Conditions

When + polarity and - polarity are detected at the same time.

Supposed
Causes

- Defect of schedule timer PC board

Troubleshooting



Caution

Be sure to turn off power switch before connect or disconnect connector, or parts damage may be occurred.

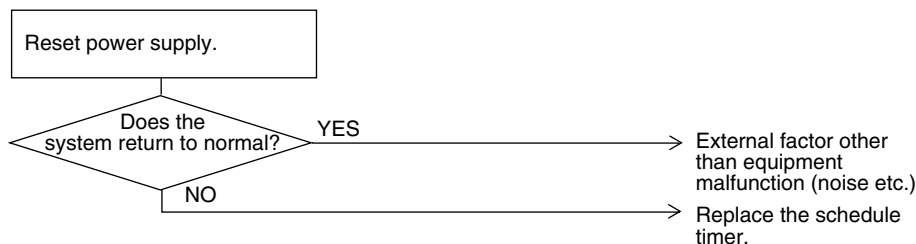

(V2837)

7.3 “M8” Malfunction of Transmission between Optional Controllers for Centralized Control

Remote Controller Display

M8

Applicable Models

All models of indoor units, schedule timer

Method of Malfunction Detection

Detect the malfunction according to DIII-NET transmission data. (The system will be automatically reset.)

Malfunction Decision Conditions

When the optional controllers for centralized control, which was connected once, shows no response.

Supposed Causes

- Malfunction of transmission between optional controllers for centralized control
- Defect of PC board of optional controllers for centralized control

Troubleshooting



Caution

Be sure to turn off power switch before connect or disconnect connector, or parts damage may be occurred.

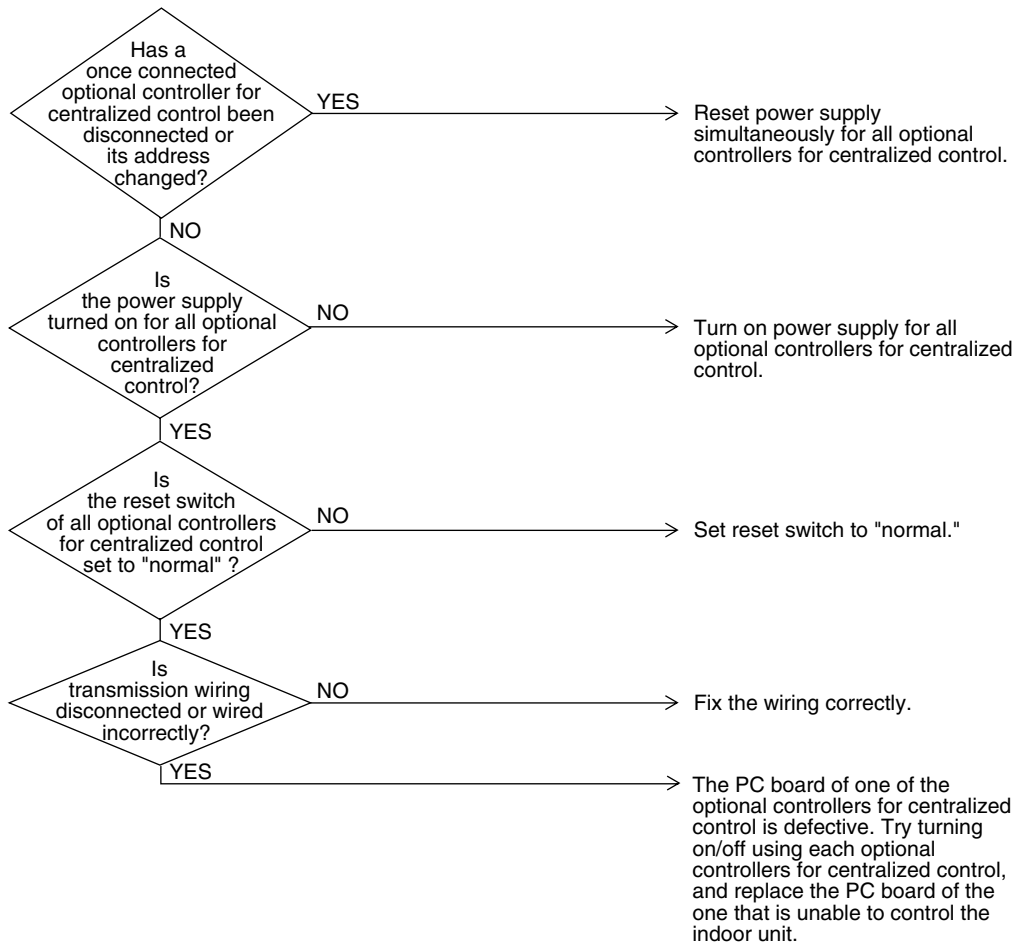

(V2838)

7.4 “*MR*” Improper Combination of Optional Controllers for Centralized Control

Remote Controller Display	<i>MR</i>
Applicable Models	All models of indoor units schedule timer
Method of Malfunction Detection	Detect the malfunction according to DIII-NET transmission data.
Malfunction Decision Conditions	When the schedule timer is set to individual use mode, other central component is present. When multiple master controllers are present.
Supposed Causes	<ul style="list-style-type: none"> ■ Improper combination of optional controllers for centralized control ■ More than one master controller is connected. ■ Defect of PC board of optional controller for centralized control

Troubleshooting



Caution

Be sure to turn off power switch before connect or disconnect connector, or parts damage may be occurred.

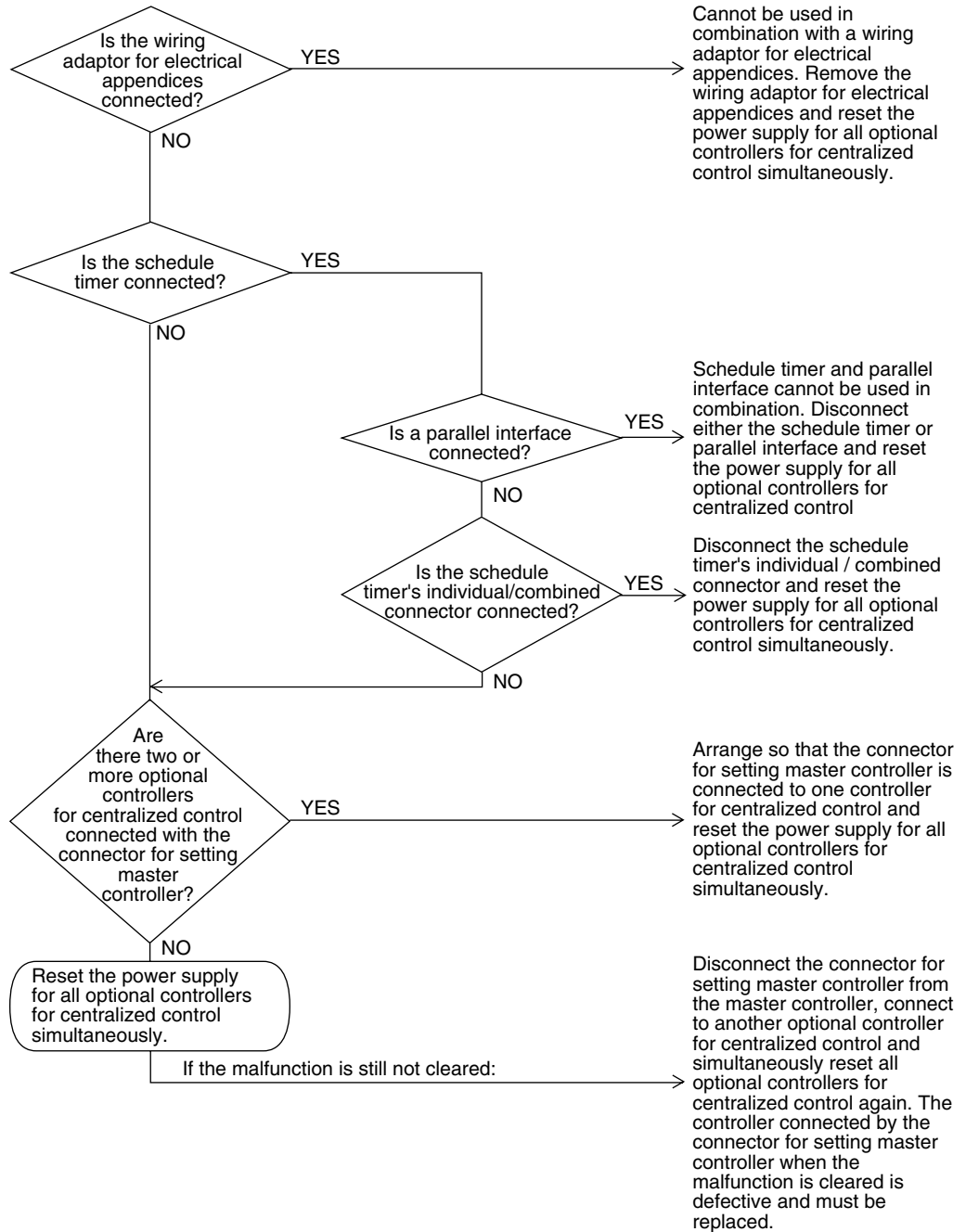

(V2839)

7.5 “MC” Address Duplication, Improper Setting

Remote
Controller
Display

MC

Applicable
Models

All models of indoor units,
schedule timer

Method of
Malfunction
Detection

Detect the malfunction according to DIII-NET transmission data.

Malfunction
Decision
Conditions

When two or more schedule timers are connected.

Supposed
Causes

- Address duplication of schedule timer

Troubleshooting



Caution

Be sure to turn off power switch before connect or disconnect connector, or parts damage may be occurred.

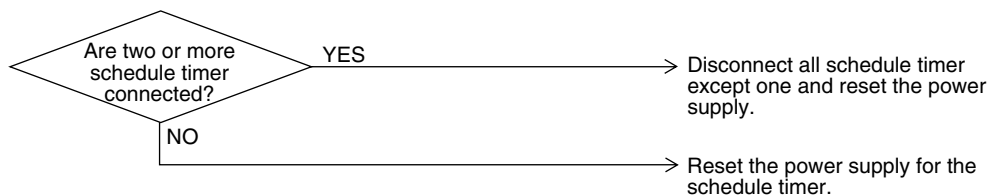

(V2840)

8. Check

Check No. 1

Check on connector of fan motor (Power supply cable)

(1) Turn off the power supply.

Measure the resistance between phases of U,V,W at the motor side connectors (three-core wire) to check that the values are balanced and there is no short circuiting, while connector or relay connector is disconnected.

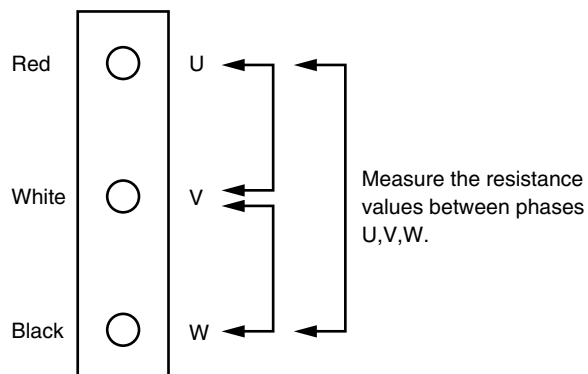

Check No. 2**Check for Fan Speed Pulse Input on Outdoor Unit PC Board**

- (1) Disconnect the connector X206A with the power supply OFF and Operation OFF.
- (2) Is the voltage between pins 4 and 3 of X206A about 15 VDC after turning the power supply on?
- (3) Is the voltage between pins 4 and 1 of X206A about 5 VDC?
- (4) Connect the connector X206A with the power supply OFF and Operation OFF.
- (5) When making one turn of the upper fan motor by hand after turning the power supply on, is a pulse (0 and 5 V) generated 4 times between pins 4 and 1 of X206A? (Measure at the contact terminal on the harness side with the connector connected.)
- (6) Disconnect the connector X207A with the power supply OFF and Operation OFF.
- (7) Is the voltage between pins 4 and 3 of X207A about 15 VDC after turning the power supply on?
- (8) Is the voltage between pins 4 and 1 of X207A about 5 VDC?
- (9) Connect the connector X207A with the power supply OFF and Operation OFF.
- (10) When making one turn of the lower fan motor by hand after turning the power supply on, is a pulse (0 and 5 V) generated 4 times between pins 4 and 1 of X207A?

(2) (7): NO → Faulty PC board → Replace the PC board.

(3) (8): NO → Faulty PC board → Replace the PC board.

(5)(10): NO → Faulty hall IC → Replace the DC fan motor.

(2) (3) (5) (7) (8) (10): YES → Replace the PC board.

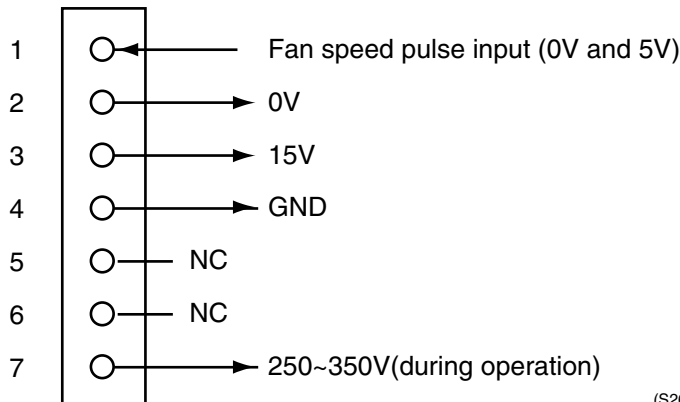

(S2679)

Part 8

Appendix

- 1. Piping Diagrams..... 184
 - 1.1 Outdoor Unit..... 184
 - 1.2 Indoor Unit 185
- 2. Wiring Diagrams for Reference..... 186
 - 2.1 Outdoor Unit..... 186
 - 2.2 Indoor Unit 187
- 3. Thermistor Resistance / Temperature Characteristics..... 190
- 4. Pressure Sensor 192

1. Piping Diagrams

1.1 Outdoor Unit

RXYMQ36MVJU

RXYMQ48MVJU

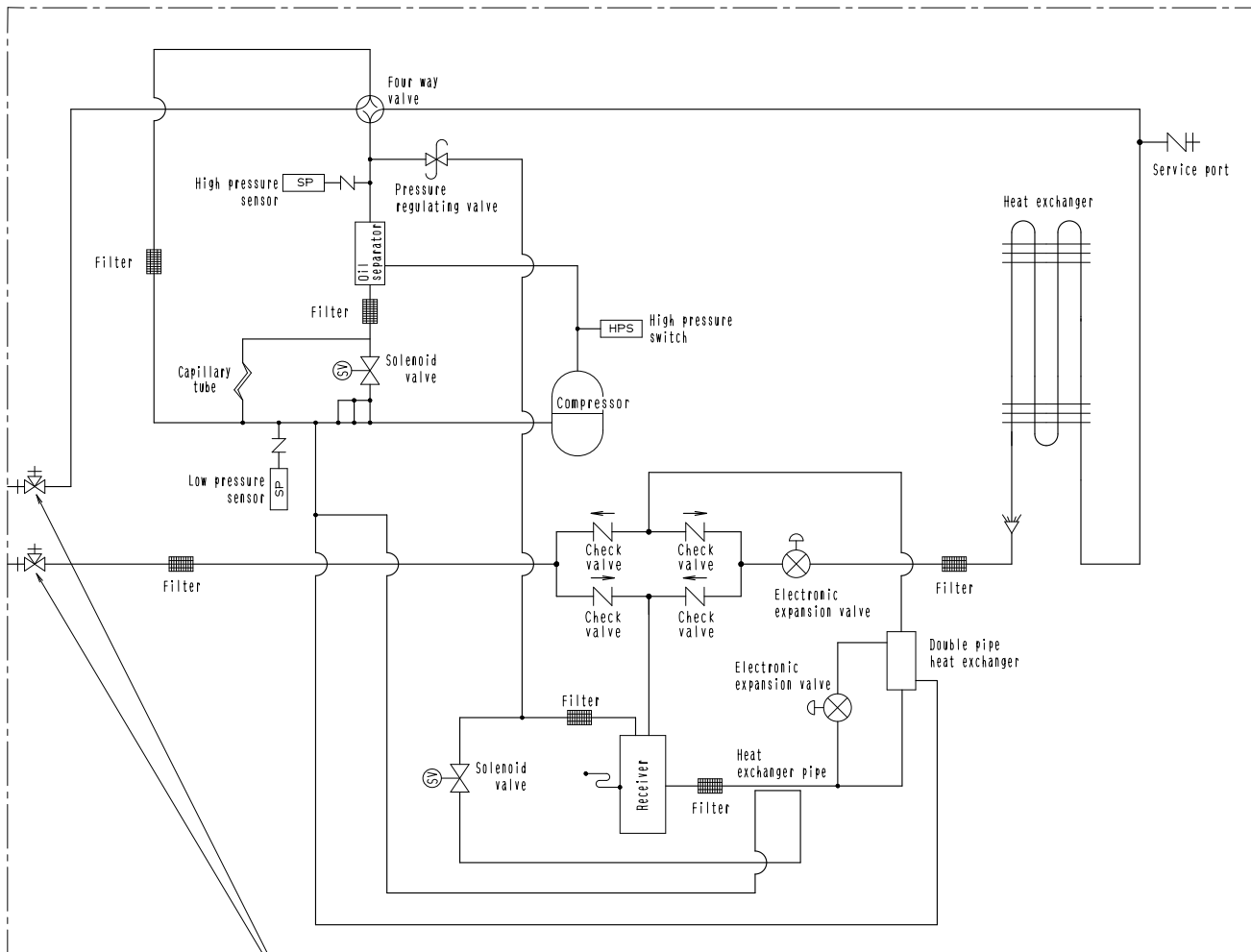

Stop valve (With service port on field piping side $\phi 5/16$ flare connection)

3D047385

1.2 Indoor Unit

- FXFQ 12M / 18M / 24M / 30M / 36MVJU
- FXSQ 12M / 18M / 24M / 30M / 36M / 48MVJU
- FXMQ 30M / 36M / 48MVJU
- FXHQ 12M / 24M / 36MVJU
- FXAQ 12M / 18M / 24MVJU
- FXLQ 12M / 18M / 24MVJU
- FXNQ 12M / 18M / 24MVJU

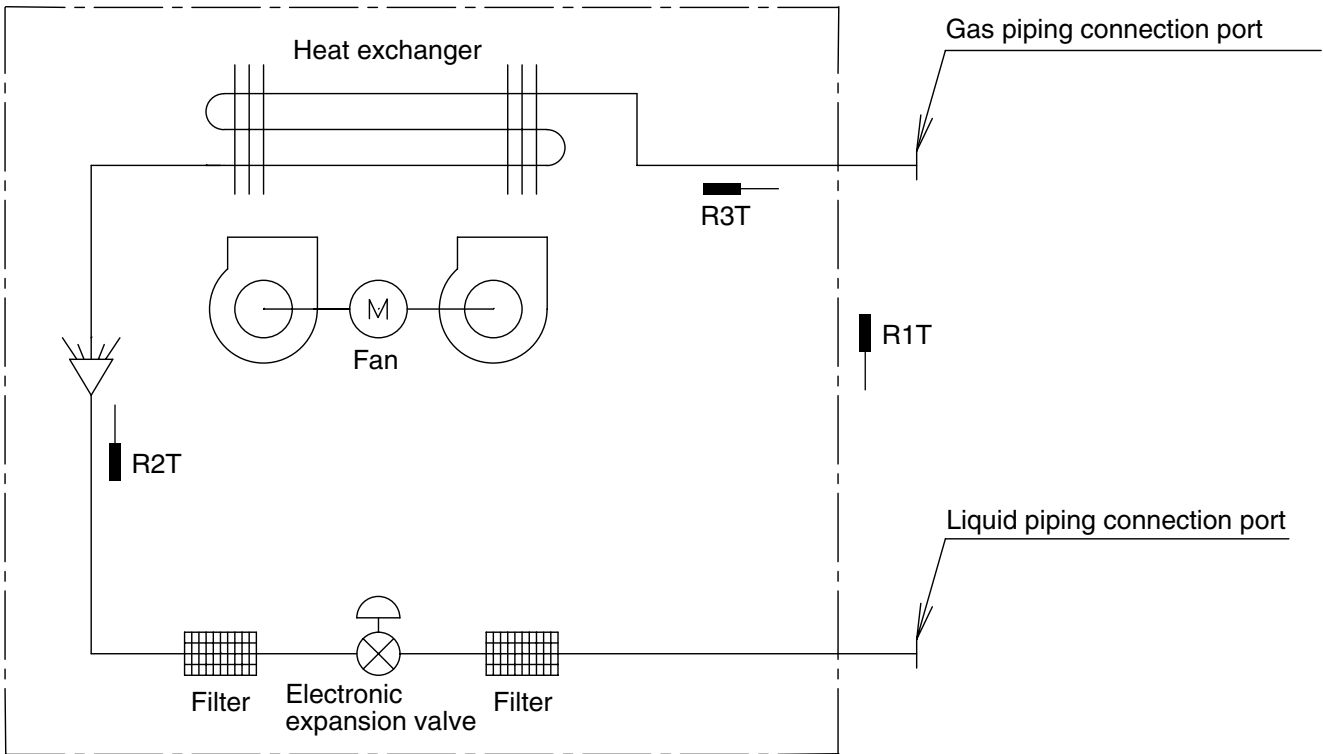

J:DU220-602J

- R1T : Thermistor for suction air temperature
- R2T : Thermistor for liquid line temperature
- R3T : Thermistor for gas line temperature

(in)

Capacity	GAS	Liquid
12/18M	φ1/2	φ1/4
24/30/36/48M	φ5/8	φ3/8

2.2 Indoor Unit

FXFQ12M / 18M / 24M / 30M / 36MVJU

INDOOR UNIT		RECEIVER/DISPLAY UNIT (ATTACHED TO WIRELESS REMOTE CONTROLLER)	
A1P	PRINTED CIRCUIT BOARD	A2P	PRINTED CIRCUIT BOARD
C1	CAPACITOR (M1F)	A3P	PRINTED CIRCUIT BOARD
F1U	FUSE (CDS5A/250V)	BS1	PUSH BUTTON (ON/OFF)
HAP	LIGHT EMITTING DIODE (SERVICE MONITOR-GREEN)	H1P	LIGHT EMITTING DIODE (ON-RED)
KPR	MAGNETIC RELAY (M1P)	H2P	LIGHT EMITTING DIODE (TIMER-GREEN)
M1F	MOTOR (INDOOR FAN)	H3P	LIGHT EMITTING DIODE (FILTER SIGN-RED)
M1P	MOTOR (DRAIN PUMP)	H4P	LIGHT EMITTING DIODE (DEFROST-ORANGE)
M1S	MOTOR (SWING FLAP)	SS1	SELECTOR SWITCH (MAIN/SUB)
Q1F	THERMO SWITCH (M1F EMBEDDED)	SS2	SELECTOR SWITCH (WIRELESS ADDRESS SET)
R1T	THERMISTOR (AIR)	X1A	CONNECTOR FOR OPTIONAL PARTS (ELECTRONIC EXPANSION VALVE)
R2T-R3T	THERMISTOR (COIL)	X23A	CONNECTOR (WIRELESS REMOTE CONTROLLER)
S1L	FLOAT SWITCH		
T1R	TRANSFORMER (208-230V/22V)		
V1TR	TRIAC		
X1M	TERMINAL STRIP (POWER)		
X2M	TERMINAL STRIP (CONTROL)		
Y1E	ELECTRONIC EXPANSION VALVE		
	WIRED REMOTE CONTROLLER		
R1T	THERMISTOR (AIR)		
SS1	SELECTOR SWITCH (MAIN/SUB)		

NOTES)

- : TERMINAL
: CONNECTOR
: FIELD WIRING
- IN CASE USING CENTRAL REMOTE CONTROLLER, CONNECT IT TO THE UNIT IN ACCORDANCE WITH THE ATTACHED INSTRUCTION MANUAL.
- X23A IS CONNECTED WHEN THE WIRELESS REMOTE CONTROLLER KIT IS BEING USED.
- WHEN CONNECTING THE INPUT WIRES FROM OUTSIDE, FORCED OFF OR ON/OFF CONTROL OPERATION CAN BE SELECTED BY REMOTE CONTROLLER. IN DETAILS, REFER TO THE INSTALLATION MANUAL ATTACHED THE UNIT.
- SYMBOLS SHOW AS FOLLOWS
 (BLK:BLACK BLU:BLUE ORG:ORANGE PNK:PINK
 RED:RED WHT:WHITE YLW:YELLOW)
- USE COPPER CONDUCTORS ONLY.

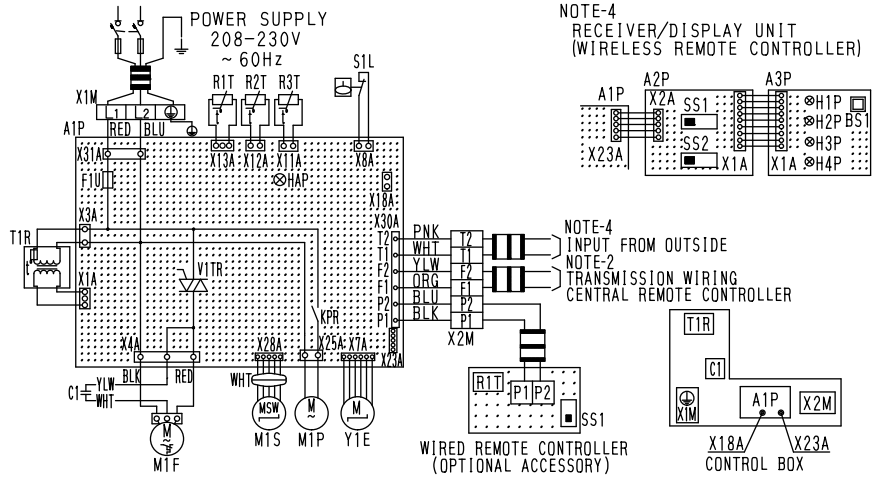

3D042620B

FXSQ12M / 18M / 24M / 30M / 36M / 48MVJU

INDOOR UNIT		WIRED REMOTE CONTROLLER	
A1P	PRINTED CIRCUIT BOARD	R1T	THERMISTOR (AIR)
A2P	TERMINAL BOARD	SS1	SELECTOR SWITCH (MAIN/SUB)
C1	CAPACITOR (M1F)	X18A	CONNECTOR (WIRING ADAPTOR FOR ELECTRONIC EXPANSION VALVE)
F1U	FUSE (CDS5A/250V)		
HAP	LIGHT EMITTING DIODE (SERVICE MONITOR-GREEN)		
K1R-K3R	MAGNETIC RELAY (M1F)		
KPR	MAGNETIC RELAY (M1P)		
M1F	MOTOR (INDOOR FAN)		
M1P	MOTOR (DRAIN PUMP)		
Q1M	THERMO SWITCH (M1F EMBEDDED)		
R1T	THERMISTOR (AIR)		
R2T-R3T	THERMISTOR (COIL)		
S1L	FLOAT SWITCH		
T1R	TRANSFORMER (208-230V/22V)		
X1M	TERMINAL BLOCK (POWER)		
X2M	TERMINAL BLOCK (CONTROL)		
Y1E	ELECTRONIC EXPANSION VALVE		

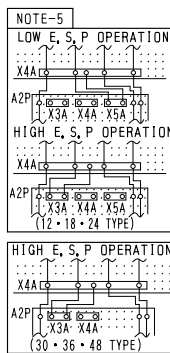

NOTES)

- : TERMINAL BLOCK, : CONNECTOR, : TERMINAL
- : FIELD WIRING
- IN CASE USING CENTRAL REMOTE CONTROLLER, CONNECT IT TO THE UNIT IN ACCORDANCE WITH THE ATTACHED INSTRUCTION MANUAL.
- WHEN CONNECTING THE INPUT WIRES FROM OUTSIDE, FORCED OFF OR ON/OFF CONTROL OPERATION CAN BE SELECTED BY REMOTE CONTROLLER. IN DETAILS, REFER TO THE INSTALLATION MANUAL ATTACHED THE UNIT.
- IN CASE HIGH OR LOW E.S.P. OPERATION, CHANGE OVER THE WIRING CONNECTION FROM X4A (OF A2P) TO X3A OR X5A.
- SYMBOLS SHOW AS FOLLOWS: (PNK:PINK WHT:WHITE YLW:YELLOW GRY:GRAY ORG:ORANGE BLU:BLUE BLK:BLACK RED:RED BRN:BROWN)
- USE COPPER CONDUCTORS ONLY.

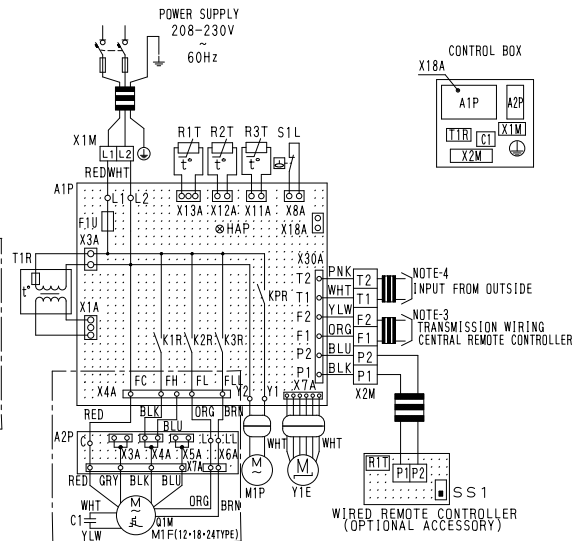

3D043177A

FXMQ30M / 36M / 48MVJU

INDOOR UNIT		R2T~R3T	THERMISTOR(COIL)
A1P	PRINTED CIRCUIT BOARD	S1L	FLOAT SWITCH
A2P	TERMINAL BOARD	T1R	TRANSFORMER(208~230V/22V)
C1	CAPACITOR(M1F)	X1M	TERMINAL BLOCK(POWER)
F1U	FUSE(5A/250V)	X2M	TERMINAL BLOCK(CONTROL)
F1U	FUSE(10A/250V)	Y1E	ELECTRONIC EXPANSION VALVE
HAP	LIGHT EMITTING DIODE (SERVICE MONITOR-GREEN)	SS1	SELECTOR SWITCH (MAIN/SUB)
K1R~K3R	MAGNETIC RELAY(M1F)	R1T	THERMISTOR(AIR)
M1F	MOTOR(INDOOR FAN)	X18A	CONNECTOR(WIRING ADAPTOR FOR ELECTRICAL APPENDICES)
Q1M	THERMO SWITCH (M1F EMBEDDED)		
R1T	THERMISTOR(AIR)		

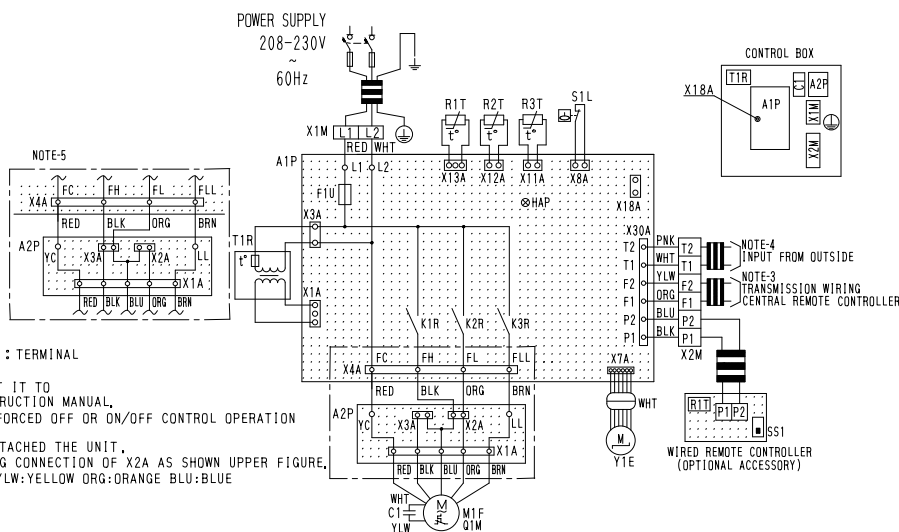

- NOTES)
1. [Symbol] : TERMINAL BLOCK, [Symbol] : CONNECTOR, [Symbol] : TERMINAL
 2. [Symbol] : FIELD WIRING
 3. IN CASE USING CENTRAL REMOTE CONTROLLER, CONNECT IT TO THE UNIT IN ACCORDANCE WITH THE ATTACHED INSTRUCTION MANUAL.
 4. WHEN CONNECTING THE INPUT WIRES FROM OUTSIDE, FORCED OFF OR ON/OFF CONTROL OPERATION CAN BE SELECTED BY REMOTE CONTROLLER. IN DETAILS, REFER TO THE INSTALLATION MANUAL ATTACHED THE UNIT.
 5. IN CASE HIGH E,S,P, OPERATION, CHANGE THE WIRING CONNECTION OF X2A AS SHOWN UPPER FIGURE.
 6. SYMBOLS SHOW AS FOLLOWS, (PNK:PINK WHT:WHITE YLW:YELLOW ORG:ORANGE BLU:BLUE BLK:BLACK RED:RED BRN:BROWN)
 7. USE COPPER CONDUCTORS ONLY.

3D043176A

FXAQ12M / 18M / 24MVJU

INDOOR UNIT			
A1P	PRINTED CIRCUIT BOARD		
F1U	FUSE(T 3, 15AH 250V)		
HAP	LIGHT EMITTING DIODE (SERVICE MONITOR GREEN)		
M1F	MOTOR(INDOOR FAN)		
M1S	MOTOR(SWING FLAP)		
R1T	THERMISTOR(AIR)		
R2T	THERMISTOR(COIL LIQUID PIPE)		
R3T	THERMISTOR(COIL GAS PIPE)		
X1M	TERMINAL BLOCK(CONTROL)		
X2M	TERMINAL BLOCK(POWER)		
Y1E	ELECTRONIC EXPANSION VALVE		
[Symbol]	POWER CIRCUIT		
RECEIVER/DISPLAY UNIT(ATTACHED TO WIRELESS REMOTE CONTROLLER)			
A2P	PRINTED CIRCUIT BOARD		
A3P	PRINTED CIRCUIT BOARD		
BS1	PUSH BUTTON(ON/OFF)		
H1P	LIGHT EMITTING DIODE(ON-RED)		
H2P	LIGHT EMITTING DIODE (TIMER-GREEN)		
H3P	LIGHT EMITTING DIODE (FILTER SIGN-RED)		
H4P	LIGHT EMITTING DIODE (DEFROST-ORANGE)		
SS1	SELECTOR SWITCH(MAIN/SUB)		
SS2	SELECTOR SWITCH (WIRELESS ADDRESS SET)		

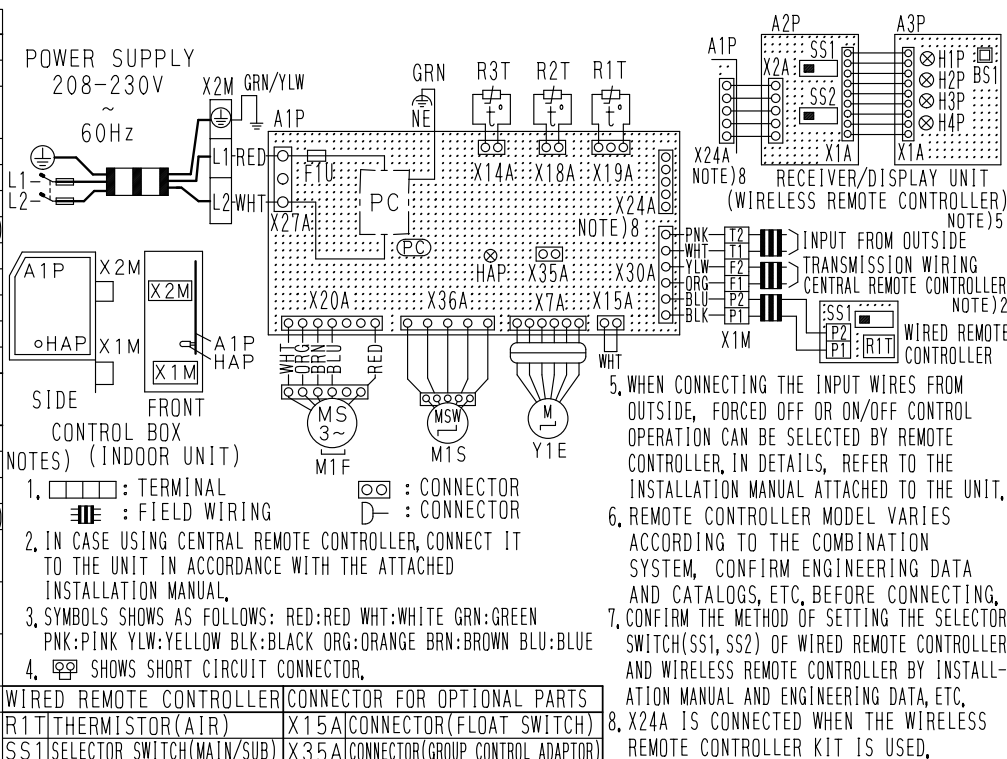

- NOTES) (INDOOR UNIT)
1. [Symbol] : TERMINAL [Symbol] : CONNECTOR [Symbol] : CONNECTOR
 2. IN CASE USING CENTRAL REMOTE CONTROLLER, CONNECT IT TO THE UNIT IN ACCORDANCE WITH THE ATTACHED INSTALLATION MANUAL.
 3. SYMBOLS SHOWS AS FOLLOWS: RED:RED WHT:WHITE GRN:GREEN PNK:PINK YLW:YELLOW BLK:BLACK ORG:ORANGE BRN:BROWN BLU:BLUE
 4. [Symbol] SHOWS SHORT CIRCUIT CONNECTOR.
 5. WHEN CONNECTING THE INPUT WIRES FROM OUTSIDE, FORCED OFF OR ON/OFF CONTROL OPERATION CAN BE SELECTED BY REMOTE CONTROLLER. IN DETAILS, REFER TO THE INSTALLATION MANUAL ATTACHED TO THE UNIT.
 6. REMOTE CONTROLLER MODEL VARIES ACCORDING TO THE COMBINATION SYSTEM, CONFIRM ENGINEERING DATA AND CATALOGS, ETC, BEFORE CONNECTING.
 7. CONFIRM THE METHOD OF SETTING THE SELECTOR SWITCH(SS1, SS2) OF WIRED REMOTE CONTROLLER AND WIRELESS REMOTE CONTROLLER BY INSTALLATION MANUAL AND ENGINEERING DATA, ETC.
 8. X24A IS CONNECTED WHEN THE WIRELESS REMOTE CONTROLLER KIT IS USED.

3D046039A

FXHQ12M / 24M / 36M

A1P	PRINTED CIRCUIT BOARD	H4P	LIGHT EMITTING DIODE (DEFROST-ORANGE)
C1	CAPACITOR (M1F)	SS1	SELECTOR SWITCH (MAIN/SUB)
F1U	FUSE (Φ5A, 250V)	SS2	SELECTOR SWITCH (WIRELESS ADDRESS SET)
HAP	LIGHT EMITTING DIODE (SERVICE MONITOR-GREEN)	X23A	CONNECTOR FOR OPTIONAL PARTS
KAR	MAGNETIC RELAY (M1S)	X18A	CONNECTOR (WIRING ADAPTOR FOR ELECTRICAL APPENDICES)
KPR	MAGNETIC RELAY		
M1F	MOTOR (INDOOR FAN)		
M1S	MOTOR (SWING FLAP)		
Q1M	THERMO SWITCH (M1F EMBEDDED)		
R1T	THERMISTOR (AIR)		
R2T	THERMISTOR (COIL LIQUID)		
R3T	THERMISTOR (COIL GAS)		
S1Q	LIMIT SWITCH (SWING FLAP)		
T1R	TRANSFORMER (208-230V/25V)		
V1TR	TRIAC		
X1M	TERMINAL BLOCK (POWER)		
X2M	TERMINAL BLOCK (CONTROL)		
Y1E	ELECTRONIC EXPANSION VALVE		

- NOTES)
1. : TERMINAL BLOCK : CONNECTOR
 2. : SHORT CIRCUIT CONNECTOR
 3. : FIELD WIRING
 3. IN CASE USING CENTRAL REMOTE CONTROLLER, CONNECT IT TO THE UNIT IN ACCORDANCE WITH THE ATTACHED INSTRUCTION MANUAL.
 4. X23A IS CONNECTED WHEN THE WIRELESS REMOTE CONTROLLER KIT IS BEING USED.
 5. WHEN CONNECTING THE INPUT WIRES FROM OUTSIDE, FORCED OFF OR ON/OFF CONTROL OPERATION CAN BE SELECTED BY REMOTE CONTROLLER. IN DETAILS, REFER TO THE INSTALLATION MANUAL ATTACHED TO THE UNIT.
 6. SYMBOLS SHOW AS FOLLOWS
(BLU:BLUE BLK:BLACK ORG:ORANGE PNK:PINK)
(RED:RED WHT:WHITE YLW:YELLOW)
 7. USE COPPER CONDUCTORS ONLY.

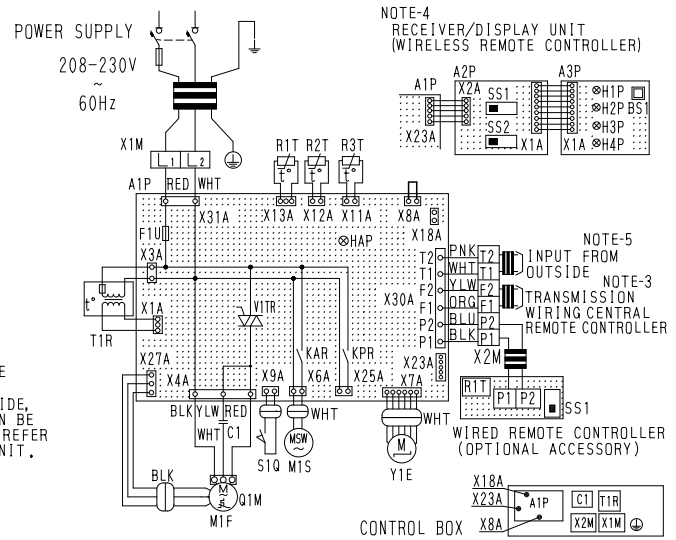

3D048116

**FXLQ12M / 18M / 24MVJU
FXNQ12M / 18M / 24MVJU**

A1P	PRINTED CIRCUIT BOARD	X2M	TERMINAL BLOCK (CONTROL)
C1R	CAPACITOR (M1F)	Y1E	ELECTRONIC EXPANSION VALVE
F1U	FUSE (Φ5A, 250V)		
HAP	LIGHT EMITTING DIODE (SERVICE MONITOR-GREEN)	R1T	THERMISTOR (AIR)
K1R-K3R	MAGNETIC RELAY (M1F)	SS1	SELECTOR SWITCH (MAIN/SUB)
M1F	MOTOR (INDOOR FAN)	X18A	CONNECTOR (WIRING ADAPTOR FOR ELECTRICAL APPENDICES)
Q1M	THERMO SWITCH (M1F EMBEDDED)		
R1T	THERMISTOR (AIR)		
R2T-R3T	THERMISTOR (COIL)		
T1R	TRANSFORMER (208-230V/25V)		
X1M	TERMINAL BLOCK (POWER)		

- NOTES)
1. : TERMINAL BLOCK, : CONNECTOR, : TERMINAL
 2. : FIELD WIRING
 3. IN CASE USING CENTRAL REMOTE CONTROLLER, CONNECT IT TO THE UNIT IN ACCORDANCE WITH THE ATTACHED INSTALLATION MANUAL.
 4. WHEN CONNECTING THE INPUT WIRES FROM OUTSIDE, FORCED OFF OR ON/OFF CONTROL OPERATION CAN BE SELECTED BY REMOTE CONTROLLER. IN DETAILS, REFER TO THE INSTALLATION MANUAL ATTACHED TO THE UNIT.
 5. SYMBOLS SHOW AS FOLLOWS (PNK:PINK WHT:WHITE YLW:YELLOW ORG:ORANGE BLU:BLUE BLK:BLACK RED:RED BRN:BROWN)
 6. USE COPPER CONDUCTORS ONLY.

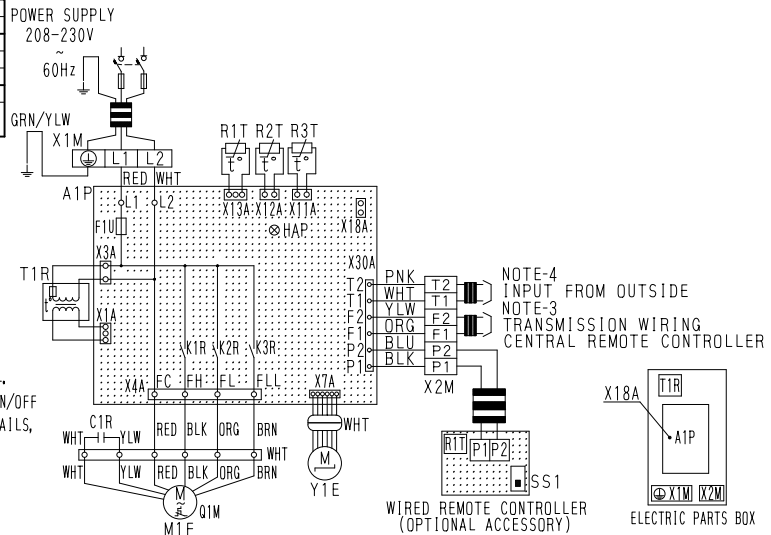

3D045644A

3. Thermistor Resistance / Temperature Characteristics

Indoor unit For air suction R1T
 For liquid pipe R2T
 For gas pipe R3T

Outdoor unit For outdoor air R1T
 For coil R2T
 For suction pipe R4T
 For Receiver gas pipe R5T

Outdoor unit for fin thermistor R1T

T°F	T°C	kΩ
14	-10	—
18	-8	—
21	-6	88.0
25	-4	79.1
28	-2	71.1
32	0	64.1
35	2	57.8
39	4	52.3
43	6	47.3
46	8	42.9
50	10	38.9
54	12	35.3
57	14	32.1
61	16	29.2
64	18	26.6
68	20	24.3
72	22	22.2
75	24	20.3
79	26	18.5
82	28	17.0
86	30	15.6
90	32	14.2
93	34	13.1
97	36	12.0
100	38	11.1
104	40	10.3
108	42	9.5
111	44	8.8
115	46	8.2
118	48	7.6
122	50	7.0
126	52	6.7
129	54	6.0
133	56	5.5
136	58	5.2
140	60	4.79
144	62	4.46
147	64	4.15
151	66	3.87
154	68	3.61
158	70	3.37
162	72	3.15
165	74	2.94
169	76	2.75
172	78	2.51
176	80	2.41
180	82	2.26
183	84	2.12
187	86	1.99
190	88	1.87
194	90	1.76
198	92	1.65
201	94	1.55
205	96	1.46
208	98	1.38

T°F	T°C	kΩ
-4.0	-20	197.81
-2.2	-19	186.53
-0.4	-18	175.97
1.4	-17	166.07
3.2	-16	156.80
5.0	-15	148.10
6.8	-14	139.94
8.6	-13	132.28
10.4	-12	125.09
12.2	-11	118.34
14.0	-10	111.99
15.8	-9	106.03
17.6	-8	100.41
19.4	-7	95.14
21.2	-6	90.17
23.0	-5	85.49
24.8	-4	81.08
26.6	-3	76.93
28.4	-2	73.01
30.2	-1	69.32
32.0	0	65.84
33.8	1	62.54
35.6	2	59.43
37.4	3	56.49
39.2	4	53.71
41.0	5	51.09
42.8	6	48.61
44.6	7	46.26
46.4	8	44.05
48.2	9	41.95
50.0	10	39.96
51.8	11	38.08
53.6	12	36.30
55.4	13	34.62
57.2	14	33.02
59.0	15	31.50
60.8	16	30.06
62.6	17	28.70
64.4	18	27.41
66.2	19	26.18
68.0	20	25.01
69.8	21	23.91
71.6	22	22.85
73.4	23	21.85
75.2	24	20.90
77.0	25	20.00
78.8	26	19.14
80.6	27	18.32
82.4	28	17.54
84.2	29	16.80
86.0	30	16.10

T°F	T°C	kΩ
86.0	30	16.10
87.8	31	15.43
89.6	32	14.79
91.4	33	14.18
93.2	34	13.59
95.0	35	13.04
96.8	36	12.51
98.6	37	12.01
100.4	38	11.52
102.2	39	11.06
104.0	40	10.63
105.8	41	10.21
107.6	42	9.81
109.4	43	9.42
111.2	44	9.06
113.0	45	8.71
114.8	46	8.37
116.6	47	8.05
118.4	48	7.75
120.2	49	7.46
122.0	50	7.18
123.8	51	6.91
125.6	52	6.65
127.4	53	6.41
129.2	54	6.65
131.0	55	6.41
132.8	56	6.18
134.6	57	5.95
136.4	58	5.74
138.2	59	5.54
140.0	60	4.96
141.8	61	4.79
143.6	62	4.62
145.4	63	4.46
147.2	64	4.30
149.0	65	4.16
150.8	66	4.01
152.6	67	3.88
154.4	68	3.75
156.2	69	3.62
158.0	70	3.50
159.8	71	3.38
161.6	72	3.27
163.4	73	3.16
165.2	74	3.06
167.0	75	2.96
168.8	76	2.86
170.6	77	2.77
172.4	78	2.68
174.2	79	2.60
176.0	80	2.51

**Outdoor Unit
Thermistors for
Discharge Pipe
(R3T)**

T°F	T°C	kΩ	T°F	T°C	kΩ	T°F	T°C	kΩ
32.0	0	640.44	122.0	50	72.32	212.0	100	13.35
33.8	1	609.31	123.8	51	69.64	213.8	101	12.95
35.6	2	579.96	125.6	52	67.06	215.6	102	12.57
37.4	3	552.00	127.4	53	64.60	217.4	103	12.20
39.2	4	525.63	129.2	54	62.24	219.2	104	11.84
41.0	5	500.66	131.0	55	59.97	221.0	105	11.49
42.8	6	477.01	132.8	56	57.80	222.8	106	11.15
44.6	7	454.60	134.6	57	55.72	224.6	107	10.83
46.4	8	433.37	136.4	58	53.72	226.4	108	10.52
48.2	9	413.24	138.2	59	51.98	228.2	109	10.21
50.0	10	394.16	140.0	60	49.96	230.0	110	9.92
51.8	11	376.05	141.8	61	48.19	231.8	111	9.64
53.6	12	358.88	143.6	62	46.49	233.6	112	9.36
55.4	13	342.58	145.4	63	44.86	235.4	113	9.10
57.2	14	327.10	147.2	64	43.30	237.2	114	8.84
59.0	15	312.41	149.0	65	41.79	239.0	115	8.59
60.8	16	298.45	150.8	66	40.35	240.8	116	8.35
62.6	17	285.18	152.6	67	38.96	242.6	117	8.12
64.4	18	272.58	154.4	68	37.63	244.4	118	7.89
66.2	19	260.60	156.2	69	36.34	246.2	119	7.68
68.0	20	249.00	158.0	70	35.11	248.0	120	7.47
69.8	21	238.36	159.8	71	33.92	249.8	121	7.26
71.6	22	228.05	161.6	72	32.78	251.6	122	7.06
73.4	23	218.24	163.4	73	31.69	253.4	123	6.87
75.2	24	208.90	165.2	74	30.63	255.2	124	6.69
77.0	25	200.00	167.0	75	29.61	257.0	125	6.51
78.8	26	191.53	168.8	76	28.64	258.8	126	6.33
80.6	27	183.46	170.6	77	27.69	260.6	127	6.16
82.4	28	175.77	172.4	78	26.79	262.4	128	6.00
84.2	29	168.44	174.2	79	25.91	264.2	129	5.84
86.0	30	161.45	176.0	80	25.07	266.0	130	5.69
86.0	31	154.79	177.8	81	24.26	267.8	131	5.54
87.8	32	148.43	179.6	82	23.48	269.6	132	5.39
89.6	33	142.37	181.4	83	22.73	271.4	133	5.25
91.4	34	136.59	183.2	84	22.01	273.2	134	5.12
93.2	35	131.06	185.0	85	21.31	275.0	135	4.98
95.0	36	125.79	186.8	86	20.63	276.8	136	4.86
96.8	37	120.76	188.6	87	19.98	278.6	137	4.73
98.6	38	115.95	190.4	88	19.36	280.4	138	4.61
100.4	39	111.35	192.2	89	18.75	282.2	139	4.49
102.2	40	106.96	194.0	90	18.17	284.0	140	4.38
104.0	41	102.76	195.8	91	17.61	285.8	141	4.27
105.8	42	98.75	197.6	92	17.07	287.6	142	4.16
107.6	43	94.92	199.4	93	16.54	289.4	143	4.06
109.4	44	91.25	201.2	94	16.04	291.2	144	3.96
111.2	45	87.74	203.0	95	15.55	293.0	145	3.86
113.0	46	84.38	204.8	96	15.08	294.8	146	3.76
114.8	47	81.16	206.6	97	14.62	296.6	147	3.67
116.6	48	78.09	208.4	98	14.18	298.4	148	3.58
118.4	49	75.14	210.2	99	13.76	300.2	149	3.49
120.2	50	72.32	212.0	100	13.35	302.0	150	3.41

4. Pressure Sensor

$P_H = 1.38V - 0.69$
 $P_L = 0.57V - 0.28$
 P_H : High pressure
 P_L : Low pressure
 V_L : Low pressure
 V : Voltage (V)

P_H : Detected Pressure [High Side]
 P_L : Detected Pressure [Low Side]
 V_H : Output Voltage [High Side] V_{DC}
 V_L : Output Voltage [Low Side] V_{DC}

Detected Pressure
 P_H, P_L
 (psi) MPa

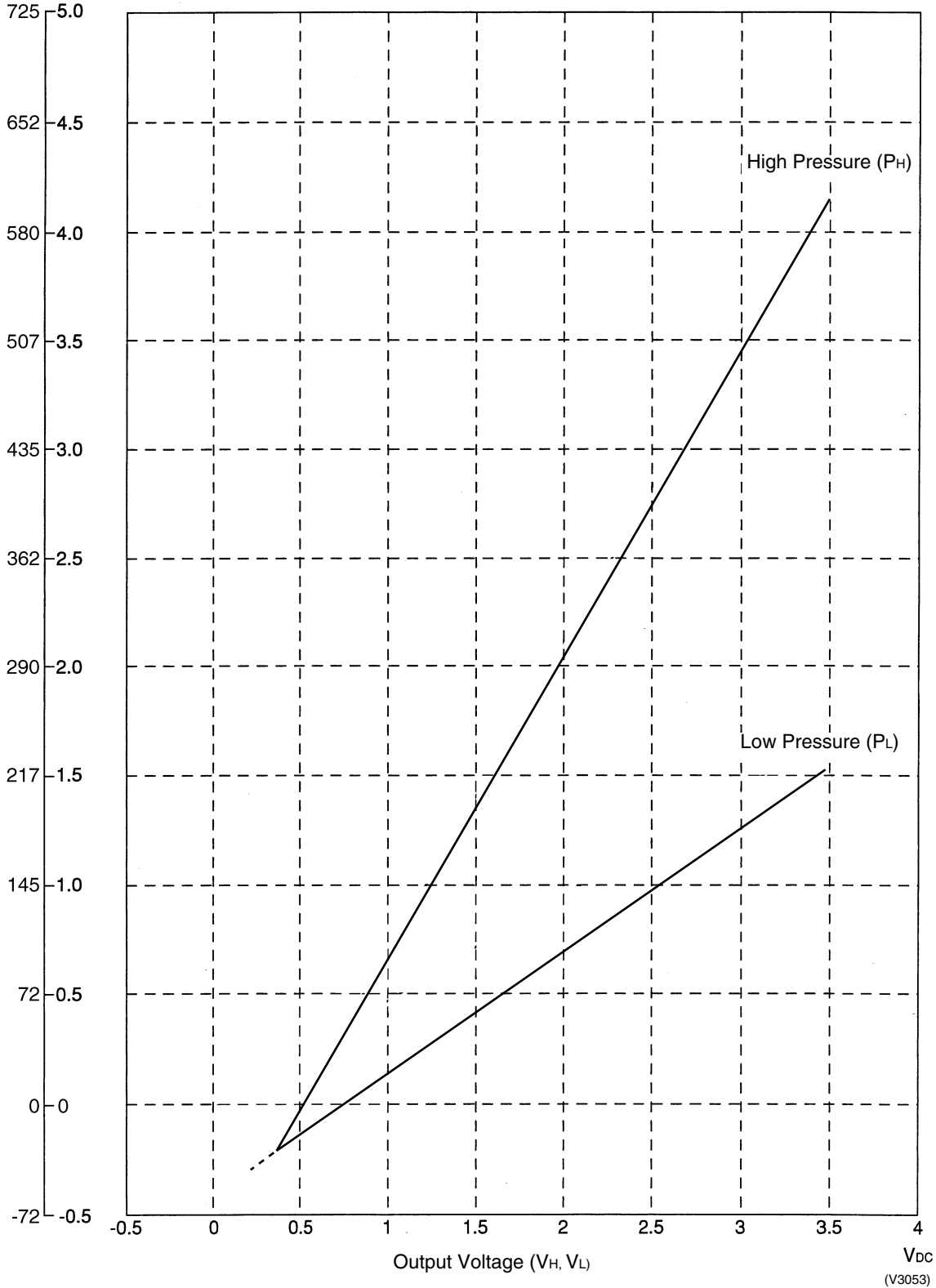

Part 9

Precautions for New Refrigerant (R410A)

1. Precautions for New Refrigerant (R410A)	194
1.1 Outline.....	194
1.2 Service Tools	196

1. Precautions for New Refrigerant (R410A)

1.1 Outline

1.1.1 About Refrigerant R410A

- Characteristics of new refrigerant, R410A
 1. Performance
Almost the same performance as R22 and R407C
 2. Pressure
Working pressure is approx. 1.4 times more than R22 and R407C.
 3. Refrigerant composition
Few problems in composition control, since it is a Quasi-azeotropic mixture refrigerant.

	HFC units (Units using new refrigerants)		HCFC units
Refrigerant name	R407C	R410A	R22
Composing substances	Non-azeotropic mixture of HFC32, HFC125 and HFC134a (*1)	Quasi-azeotropic mixture of HFC32 and JFC125 (*1)	Single-component refrigerant
Design pressure	3.2 MPa (gauge pressure) = 32.6 kgf/cm ² = 464 psi	4.0 MPa (gauge pressure) = 40.8 kgf/cm ² = 580 psi	2.75MPa (gauge pressure) = 28.0 kgf/cm ² = 399 psi
Refrigerant oil	Synthetic oil (Ether)		Mineral oil (Suniso)
Ozone destruction factor (ODP)	0	0	0.05
Combustibility	None	None	None
Toxicity	None	None	None

- ★1. Non-azeotropic mixture refrigerant: mixture of two or more refrigerants having different boiling points.
- ★2. Quasi-azeotropic mixture refrigerant: mixture of two or more refrigerants having similar boiling points.
- ★3. The design pressure is different at each product. Please refer to the installation manual for each product.

(Reference) 1 MPa ≙ 10.19716 kgf / cm²
1 MPa ≙ 145 psi

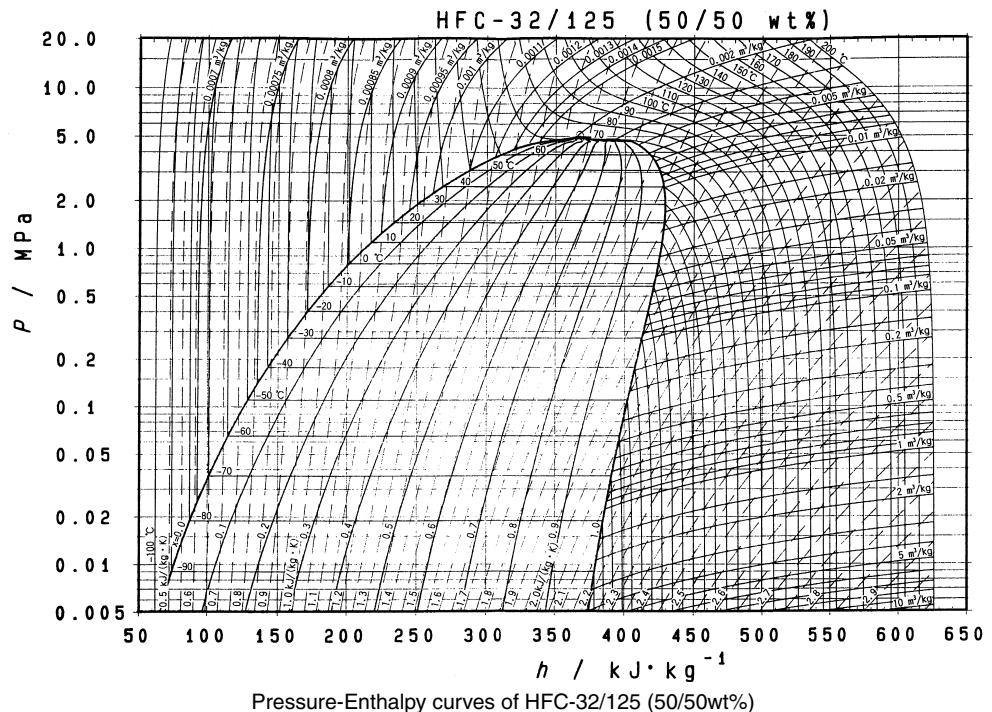

■ Thermodynamic characteristic of R410A

DAIREP ver2.0

Temperature (°C)	Steam pressure (kPa)		Density (kg/m ³)		Specific heat at constant pressure (kJ/kgK)		Specific enthalpy (kJ/kg)		Specific entropy (kJ/KgK)	
	Liquid	Vapor	Liquid	Vapor	Liquid	Vapor	Liquid	Vapor	Liquid	Vapor
-70	36.13	36.11	1410.7	1.582	1.372	0.695	100.8	390.6	0.649	2.074
-68	40.83	40.80	1404.7	1.774	1.374	0.700	103.6	391.8	0.663	2.066
-66	46.02	45.98	1398.6	1.984	1.375	0.705	106.3	393.0	0.676	2.058
-64	51.73	51.68	1392.5	2.213	1.377	0.710	109.1	394.1	0.689	2.051
-62	58.00	57.94	1386.4	2.463	1.378	0.715	111.9	395.3	0.702	2.044
-60	64.87	64.80	1380.2	2.734	1.379	0.720	114.6	396.4	0.715	2.037
-58	72.38	72.29	1374.0	3.030	1.380	0.726	117.4	397.6	0.728	2.030
-56	80.57	80.46	1367.8	3.350	1.382	0.732	120.1	398.7	0.741	2.023
-54	89.49	89.36	1361.6	3.696	1.384	0.737	122.9	399.8	0.754	2.017
-52	99.18	99.03	1355.3	4.071	1.386	0.744	125.7	400.9	0.766	2.010
-51.58	101.32	101.17	1354.0	4.153	1.386	0.745	126.3	401.1	0.769	2.009
-50	109.69	109.51	1349.0	4.474	1.388	0.750	128.5	402.0	0.779	2.004
-48	121.07	120.85	1342.7	4.909	1.391	0.756	131.2	403.1	0.791	1.998
-46	133.36	133.11	1336.3	5.377	1.394	0.763	134.0	404.1	0.803	1.992
-44	146.61	146.32	1330.0	5.880	1.397	0.770	136.8	405.2	0.816	1.987
-42	160.89	160.55	1323.5	6.419	1.401	0.777	139.6	406.2	0.828	1.981
-40	176.24	175.85	1317.0	6.996	1.405	0.785	142.4	407.3	0.840	1.976
-38	192.71	192.27	1310.5	7.614	1.409	0.792	145.3	408.3	0.852	1.970
-36	210.37	209.86	1304.0	8.275	1.414	0.800	148.1	409.3	0.864	1.965
-34	229.26	228.69	1297.3	8.980	1.419	0.809	150.9	410.2	0.875	1.960
-32	249.46	248.81	1290.6	9.732	1.424	0.817	153.8	411.2	0.887	1.955
-30	271.01	270.28	1283.9	10.53	1.430	0.826	156.6	412.1	0.899	1.950
-28	293.99	293.16	1277.1	11.39	1.436	0.835	159.5	413.1	0.911	1.946
-26	318.44	317.52	1270.2	12.29	1.442	0.844	162.4	414.0	0.922	1.941
-24	344.44	343.41	1263.3	13.26	1.448	0.854	165.3	414.9	0.934	1.936
-22	372.05	370.90	1256.3	14.28	1.455	0.864	168.2	415.7	0.945	1.932
-20	401.34	400.06	1249.2	15.37	1.461	0.875	171.1	416.6	0.957	1.927
-18	432.36	430.95	1242.0	16.52	1.468	0.886	174.1	417.4	0.968	1.923
-16	465.20	463.64	1234.8	17.74	1.476	0.897	177.0	418.2	0.980	1.919
-14	499.91	498.20	1227.5	19.04	1.483	0.909	180.0	419.0	0.991	1.914
-12	536.58	534.69	1220.0	20.41	1.491	0.921	182.9	419.8	1.003	1.910
-10	575.26	573.20	1212.5	21.86	1.499	0.933	185.9	420.5	1.014	1.906
-8	616.03	613.78	1204.9	23.39	1.507	0.947	189.0	421.2	1.025	1.902
-6	658.97	656.52	1197.2	25.01	1.516	0.960	192.0	421.9	1.036	1.898
-4	704.15	701.49	1189.4	26.72	1.524	0.975	195.0	422.6	1.048	1.894
-2	751.64	748.76	1181.4	28.53	1.533	0.990	198.1	423.2	1.059	1.890
0	801.52	798.41	1173.4	30.44	1.543	1.005	201.2	423.8	1.070	1.886
2	853.87	850.52	1165.3	32.46	1.552	1.022	204.3	424.4	1.081	1.882
4	908.77	905.16	1157.0	34.59	1.563	1.039	207.4	424.9	1.092	1.878
6	966.29	962.42	1148.6	36.83	1.573	1.057	210.5	425.5	1.103	1.874
8	1026.5	1022.4	1140.0	39.21	1.584	1.076	213.7	425.9	1.114	1.870
10	1089.5	1085.1	1131.3	41.71	1.596	1.096	216.8	426.4	1.125	1.866
12	1155.4	1150.7	1122.5	44.35	1.608	1.117	220.0	426.8	1.136	1.862
14	1224.3	1219.2	1113.5	47.14	1.621	1.139	223.2	427.2	1.147	1.859
16	1296.2	1290.8	1104.4	50.09	1.635	1.163	226.5	427.5	1.158	1.855
18	1371.2	1365.5	1095.1	53.20	1.650	1.188	229.7	427.8	1.169	1.851
20	1449.4	1443.4	1085.6	56.48	1.666	1.215	233.0	428.1	1.180	1.847
22	1530.9	1524.6	1075.9	59.96	1.683	1.243	236.4	428.3	1.191	1.843
24	1615.8	1609.2	1066.0	63.63	1.701	1.273	239.7	428.4	1.202	1.839
26	1704.2	1697.2	1055.9	67.51	1.721	1.306	243.1	428.6	1.214	1.834
28	1796.2	1788.9	1045.5	71.62	1.743	1.341	246.5	428.6	1.225	1.830
30	1891.9	1884.2	1034.9	75.97	1.767	1.379	249.9	428.6	1.236	1.826
32	1991.3	1983.2	1024.1	80.58	1.793	1.420	253.4	428.6	1.247	1.822
34	2094.5	2086.2	1012.9	85.48	1.822	1.465	256.9	428.4	1.258	1.817
36	2201.7	2193.1	1001.4	90.68	1.855	1.514	260.5	428.3	1.269	1.813
38	2313.0	2304.0	989.5	96.22	1.891	1.569	264.1	428.0	1.281	1.808
40	2428.4	2419.2	977.3	102.1	1.932	1.629	267.8	427.7	1.292	1.803
42	2548.1	2538.6	964.6	108.4	1.979	1.696	271.5	427.2	1.303	1.798
44	2672.2	2662.4	951.4	115.2	2.033	1.771	275.3	426.7	1.315	1.793
46	2800.7	2790.7	937.7	122.4	2.095	1.857	279.2	426.1	1.327	1.788
48	2933.7	2923.6	923.3	130.2	2.168	1.955	283.2	425.4	1.339	1.782
50	3071.5	3061.2	908.2	138.6	2.256	2.069	287.3	424.5	1.351	1.776
52	3214.0	3203.6	892.2	147.7	2.362	2.203	291.5	423.5	1.363	1.770
54	3361.4	3351.0	875.1	157.6	2.493	2.363	295.8	422.4	1.376	1.764
56	3513.8	3503.5	856.8	168.4	2.661	2.557	300.3	421.0	1.389	1.757
58	3671.3	3661.2	836.9	180.4	2.883	2.799	305.0	419.4	1.403	1.749
60	3834.1	3824.2	814.9	193.7	3.191	3.106	310.0	417.6	1.417	1.741
62	4002.1	3992.7	790.1	208.6	3.650	3.511	315.3	415.5	1.433	1.732
64	4175.7	4166.8	761.0	225.6	4.415	4.064	321.2	413.0	1.450	1.722

1.2 Service Tools

R410A is used under higher working pressure, compared to previous refrigerants (R22,R407C). Furthermore, the refrigerating machine oil has been changed from Suniso oil to Ether oil, and if oil mixing is occurred, sludge results in the refrigerants and causes other problems. Therefore, gauge manifolds and charge hoses that are used with a previous refrigerant (R22,R407C) can not be used for products that use new refrigerants.

Be sure to use dedicated tools and devices.

■ Tool compatibility

Tool	Compatibility			Reasons for change
	HFC		HCFC	
	R410A	R407C	R22	
Gauge manifold Charge hose	×			<ul style="list-style-type: none"> Do not use the same tools for R22 and R410A. Thread specification differs for R410A and R407C.
Charging cylinder	×		○	<ul style="list-style-type: none"> Weighting instrument used for HFCs.
Gas detector	○		×	<ul style="list-style-type: none"> The same tool can be used for HFCs.
Vacuum pump (pump with reverse flow preventive function)		○		<ul style="list-style-type: none"> To use existing pump for HFCs, vacuum pump adaptor must be installed.
Weighting instrument		○		
Charge mouthpiece		×		<ul style="list-style-type: none"> Seal material is different between R22 and HFCs. Thread specification is different between R410A and others.
Flaring tool (Clutch type)		○		<ul style="list-style-type: none"> For R410A, flare gauge is necessary.
Torque wrench		○		<ul style="list-style-type: none"> Torque-up for 1/2 and 5/8
Pipe cutter		○		
Pipe expander		○		
Pipe bender		○		
Pipe assembling oil		×		<ul style="list-style-type: none"> Due to refrigerating machine oil change. (No Suniso oil can be used.)
Refrigerant recovery device	Check your recovery device.			
Refrigerant piping	See the chart below.			<ul style="list-style-type: none"> Only φ19.1 is changed to 1/2H material while the previous material is "O".

As for the charge mouthpiece and packing, 1/2UNF20 is necessary for mouthpiece size of charge hose.

■ Copper tube material and thickness

Pipe size	R407C		R410A	
	Material	Thickness [mm]	Material	Thickness [mm]
φ6.4	O	0.8	O	0.8
φ9.5	O	0.8	O	0.8
φ12.7	O	0.8	O	0.8
φ15.9	O	1.0	O	1.0
φ19.1	O	1.0	1/2H	1.0
φ22.2	1/2H	1.0	1/2H	1.0
φ25.4	1/2H	1.0	1/2H	1.0
φ28.6	1/2H	1.0	1/2H	1.0
φ31.8	1/2H	1.2	1/2H	1.1
φ38.1	1/2H	1.4	1/2H	1.4
φ44.5	1/2H	1.6	1/2H	1.6

* O: Soft (Annealed)

H: Hard (Drawn)

1. Flaring tool

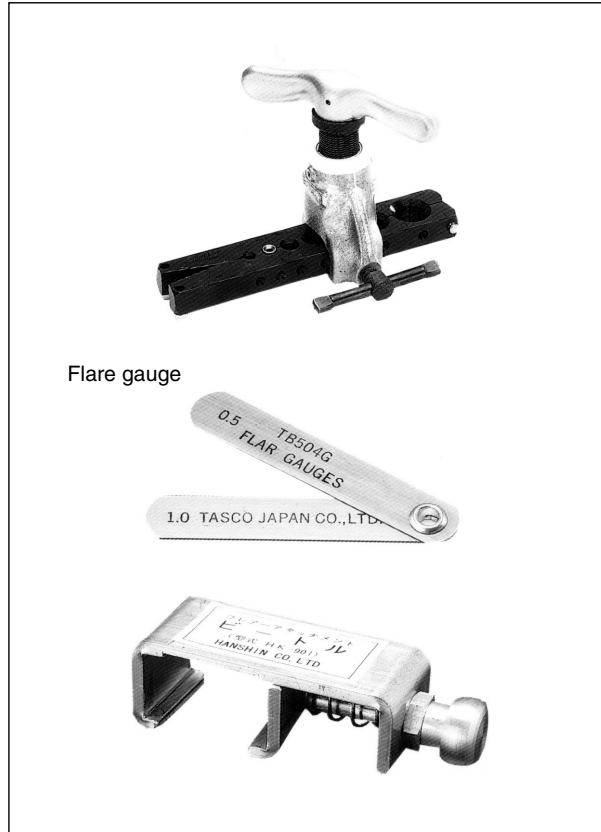

- Specifications
- Dimension A

Unit:mm

Nominal size	Tube O.D. Do	A ⁺⁰ _{-0.4}	
		Class-2 (R410A)	Class-1 (Conventional)
1/4	6.35	9.1	9.0
3/8	9.52	13.2	13.0
1/2	12.70	16.6	16.2
5/8	15.88	19.7	19.4
3/4	19.05	24.0	23.3

- Differences
- Change of dimension A

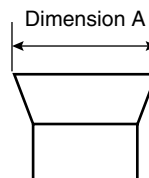

For class-1: R407C
For class-2: R410A

Conventional flaring tools can be used when the work process is changed.
(change of work process)

Previously, a pipe extension margin of 0 to 0.5mm was provided for flaring. For R410A air conditioners, perform pipe flaring with a pipe extension margin of 1.0 to 1.5mm.
(For clutch type only)

Conventional tool with pipe extension margin adjustment can be used.

2. Torque wrench



■ Specifications

- Dimension B

Unit:mm

Nominal size	Class-1	Class-2	Previous
1/2	24	26	24
5/8	27	29	27

No change in tightening torque

No change in pipes of other sizes

■ Differences

- Change of dimension B
Only 1/2", 5/8" are extended

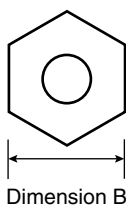

For class-1: R407C
For class-2: R410A

3. Vacuum pump with check valve

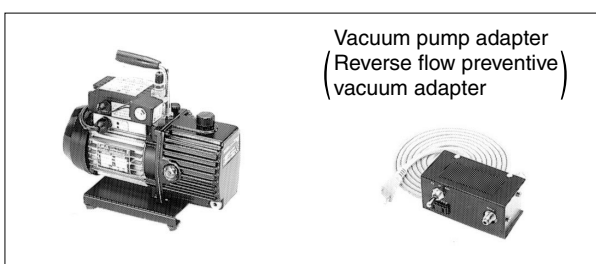

Vacuum pump adapter
(Reverse flow preventive)
vacuum adapter

■ Specifications

- Discharge speed
 - 50 l/min (50Hz)
 - 60 l/min (60Hz)
- Suction port UNF7/16-20(1/4 Flare)
UNF1/2-20(5/16 Flare) with adapter
- Maximum degree of vacuum
-14.5 psi (5 torr - 755 mmHg)

■ Differences

- Equipped with function to prevent reverse oil flow
- Previous vacuum pump can be used by installing adapter.

4. Leak tester



■ Specifications

- Hydrogen detecting type, etc.
- Applicable refrigerants
R410A, R407C, R404A, R507A, R134a, etc.

■ Differences

- Previous testers detected chlorine. Since HFCs do not contain chlorine, new tester detects hydrogen.

5. Refrigerant oil



■ Specifications

- Contains synthetic oil, therefore it can be used for piping work of every refrigerant cycle.
- Offers high rust resistance and stability over long period of time.

■ Differences

- Can be used for R410A and R22 units.

6. Gauge manifold for R410A

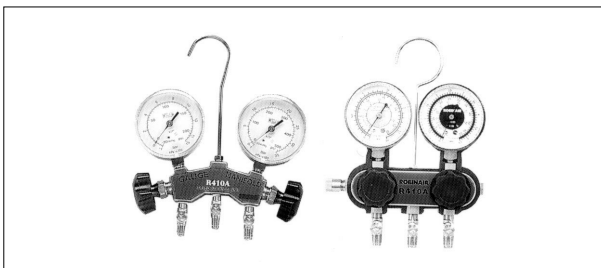

■ Specifications

- High pressure gauge
15 to 770 psi (-76 cmHg to 53 kg/cm²)
- Low pressure gauge
15 to 550 psi (-76 cmHg to 38 kg/cm²)

- 1/4" → 5/16" (2min → 2.5min)
 - No oil is used in pressure test of gauges.
→ For prevention of contamination
 - Temperature scale indicates the relationship between pressure and temperature in gas saturated state.
- Differences
- Change in pressure
 - Change in service port diameter

7. Charge hose for R410A

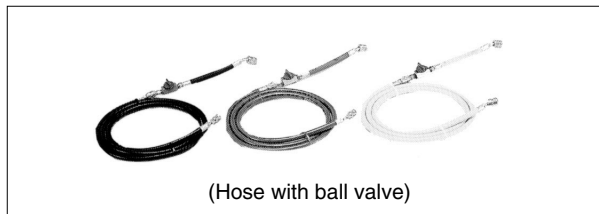

- Specifications
- Working pressure 737 psi (51.8 kg/cm²)
 - Rupture pressure 3685 psi (259 kg/cm²)
 - Available with and without hand-operate valve that prevents refrigerant from outflow.
- Differences
- Pressure proof hose
 - Change in service port diameter
 - Use of nylon coated material for HFC resistance

8. Charging cylinder

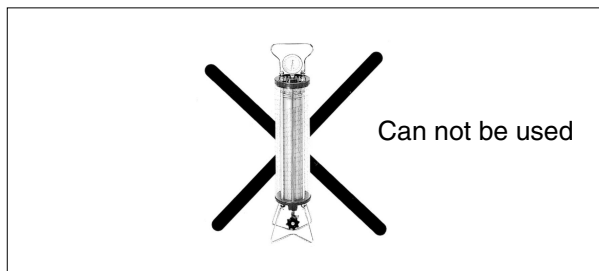

- Specifications
- Use weigher for refrigerant charge listed below to charge directly from refrigerant cylinder.
- Differences
- The cylinder can not be used for mixed refrigerant since mixing ratio is changed during charging.

When R410A is charged in liquid state using charging cylinder, foaming phenomenon is generated inside charging cylinder.

9. Weigher for refrigerant charge



■ Specifications

- High accuracy
TA101A (for 10-kg cylinder) = ± 2 g
TA101B (for 20-kg cylinder) = ± 5 g
- Equipped with pressure-resistant sight glass to check liquid refrigerant charging.
- A manifold with separate ports for HFCs and previous refrigerants is equipped as standard accessories.

■ Differences

- Measurement is based on weight to prevent change of mixing ratio during charging.

10. Charge mouthpiece



■ Specifications

- For R410A, 1/4" → 5/16" (2min → 2.5min)
- Material is changed from CR to H-NBR.

■ Differences

- Change of thread specification on hose connection side (For the R410A use)
- Change of sealer material for the HFCs use.

Index

A

A0	102
A1	103
A3	104
A6	106
A7	107
A9	109
abnormal discharge pipe temperature	127
about refrigerant R410A	194
actuation of high pressure switch	119
actuation of low pressure switch	120
address duplication of central remote controller	156
address duplication, improper setting	167, 180
AF	111
AJ	112
applicable range of field setting	63
auto restart after power failure reset	64

C

C4	113
C5	114
C9	115
CA	116
centralized control group no. setting	66
check No. 1	181
check No. 2	182
check operation	55, 85
check operation not executed	148
check work prior to turn power supply on	54
CJ	117
compressor motor lock	122
compressor PI control	30
contents of control modes	68
cool/heat mode switching	76
cooling operation fan control	32

D

defrosting operation	36
demand operation	45, 78
discharge pipe protection control	43
display "under centralized control" blinks (repeats double blink)	173
display "under centralized control" blinks (repeats single blink)	170
drain level above limit	111
drain pump control	46

E

E1	118
E3	119
E4	120

E5	122
E7	123
E9	125
electrical and functional parts	
indoor units	19
outdoor units	18
electronic expansion valve PI control	31
error of external protection device	102
external appearance	3

F

F3	127
fan motor (M1F) lock, overload	106
fan speed changeover when thermostat is off	64
faulty combination of inverter and fan driver	144
field setting	59
field setting from outdoor unit	70
filter sign setting	64
freeze prevention	51
functional parts layout	26

H

H9	128
heating operation prohibition	45
high pressure protection control	41

I

improper combination of indoor units and outdoor units, indoor units and remote controller	155
improper combination of optional controllers for centralized control	165, 178
inverter compressor abnormal	137
inverter current abnormal	138
inverter protection control	44
inverter start up error	140

J

J3	129
J5	130
J6	131
J9	132
JA	133
JC	135

L

L4	136
L5	137
L8	138
L9	140
LC	141
louver control for preventing ceiling dirt	48

low noise operation.....	78
low pressure drop due to refrigerant shortage or electronic expansion valve failure	145
low pressure protection control.....	42

M

M1.....	163, 176
M8.....	164, 177
MA	165, 178
malfunction code indication by outdoor unit PCB	100
malfunction of capacity determination device	112
malfunction of discharge pipe thermistor (R3T)....	129
malfunction of drain level control system (S1L)....	104
malfunction of high pressure sensor.....	133
malfunction of inverter radiating fin temperature rise	136
malfunction of inverter radiating fin temperature rise sensor	143
malfunction of low pressure sensor	135
malfunction of moving part of electronic expansion valve	125
malfunction of moving part of electronic expansion valve (20E)	109
malfunction of outdoor unit fan motor	123
malfunction of subcooling heat exchanger gas pipe thermistor (R5T)	132
malfunction of swing flap motor (MA)	107
malfunction of system, refrigerant system address undefined.....	160
malfunction of thermistor (R1T) for outdoor air.....	128
malfunction of thermistor (R1T) for suction air	115
malfunction of thermistor (R2T) for heat exchanger.....	113
malfunction of thermistor (R2T) for suction pipe...	130
malfunction of thermistor (R3T) for gas pipes	114
malfunction of thermistor (R4T) for outdoor unit heat exchanger.....	131
malfunction of thermistor for discharge air	116
malfunction of thermostat sensor in remote controller	117
malfunction of transmission between central remote controller and indoor unit.....	157, 161, 174
malfunction of transmission between indoor and outdoor units in the same system.....	153
malfunction of transmission between indoor units and outdoor units.....	149
malfunction of transmission between inverter and control pc board.....	141
malfunction of transmission between main and sub remote controllers	152
malfunction of transmission between optional controllers for centralized control	164, 177
malfunction of transmission between remote controller and indoor unit.....	151
MC	167, 180

N

normal operation.....	29
-----------------------	----

O

oil return operation.....	34
operation lamp blinks.....	168
operation mode.....	28
operation when power is turned on.....	57

P

P4	143
PC board defect.....	103, 118, 163, 176
PC board layout (outdoor unit).....	58
piping diagrams	184
PJ.....	144
power supply insufficient or instantaneous failure	146
precautions for new refrigerant (R410A).....	194
pressure equalization prior to startup	40
pressure sensor.....	192
protection control	41
pump-down residual operation	37

R

refrigerant circuit.....	24
refrigerant recovery mode.....	84
restart standby.....	38

S

service tools.....	196
setting by dip switches.....	70
setting by pushbutton switches.....	70
setting contents and code no. – VRV unit.....	62
specifications indoor units.....	7
outdoor units	6
startup control.....	33
stopping operation	39
swing flaps	52
system not set yet.....	159

T

test operation procedure and outline	54
thermistor resistance / temperature characteristics	190
thermostat sensor in remote controller	49

U

U0	145
U2	146
U3	148
U4	149
U5	151
U8	152
U9	153
UA.....	155

UC 156
UE..... 157, 161, 174
UF..... 159
UH 160

V

vacuuming mode 84

W

wiring diagrams 186

Drawings & Flow Charts

A		F	
abnormal discharge pipe temperature	127	fan motor (M1F) lock, overload	106
actuation of high pressure switch	119	faulty combination of inverter and fan driver	144
actuation of low pressure switch	120	field setting from outdoor unit	
address duplication of central remote controller ...	156	mode changing procedure	71
address duplication, improper setting	167, 180	flaring tool	197
		forced fan on	96
B		freeze prevention	51
BRC4C type	67	functional parts layout	26
BRC7C type	67		
BRC7E type	67	G	
C		gauge manifold for R410A	199
centralized control group no. setting			
BRC1C Type	66	H	
group no. setting example	67	high pressure protection control	41
charge hose for R410A	200	how to enter the service mode	95
charge mouthpiece	201		
charging cylinder	200	I	
check No. 1	181	improper combination of indoor units and outdoor	
check No. 2	182	units, indoor units and remote controller	155
check operation	55	improper combination of optional controllers for	
check operation not executed	148	centralized control	165, 178
check work prior to turn power supply on	54	individual setting	96
compressor motor lock	122	inverter compressor abnormal	137
contents of control modes		inverter current abnormal	138
how to select operation mode	69	inverter protection control	44
cooling operation fan control	32	inverter start up error	140
D		L	
discharge pipe protection control	43	leak tester	199
display "under centralized control" blinks		louver control for preventing ceiling dirt	48
(repeats double blink)	173	low pressure drop due to refrigerant shortage or	
display "under centralized control" blinks		electronic expansion valve failure	145
(repeats single blink)	170	low pressure protection control	42
display of sensor and address data	96		
drain level above limit	111	M	
drain pump control		malfunction hysteresis display	96
when the float switch is tripped and "AF" is		malfunction of capacity determination device	112
displayed on the remote controller	47	malfunction of discharge pipe thermistor (R3T)	129
when the float switch is tripped during		malfunction of drain level control system (S1L)	104
cooling off by thermostat	46	malfunction of high pressure sensor	133
when the float switch is tripped during		malfunction of inverter radiating fin	
heating operation	47	temperature rise	136
when the float switch is tripped while the		malfunction of inverter radiating fin	
cooling thermostat is on	46	temperature rise sensor	143
		malfunction of low pressure sensor	135
		malfunction of moving part of electronic	
E		expansion valve	125
error of external protection device	102	malfunction of moving part of electronic	
		expansion valve (20E)	109
		malfunction of outdoor unit fan motor	123

malfunction of subcooling heat exchanger gas pipe thermistor (R5T)	132	setting of demand operation image of operation in the case of A.....	81
malfunction of swing flap motor (MA)	107	image of operation in the case of A and B	81
malfunction of system, refrigerant system address undefined.....	160	image of operation in the case of B.....	81
malfunction of thermistor (R1T) for outdoor air.....	128	setting of low noise operation image of operation in the case of A.....	79
malfunction of thermistor (R1T) for suction air	115	image of operation in the case of A and B	79
malfunction of thermistor (R2T) for heat exchanger.....	113	image of operation in the case of B.....	79
malfunction of thermistor (R2T) for suction pipe...	130	simplified remote controller.....	61
malfunction of thermistor (R3T) for gas pipes	114	system not set yet.....	159
malfunction of thermistor (R4T) for outdoor unit heat exchanger.....	131	T the inspection / test button.....	90
malfunction of thermistor for discharge air	116	thermostat sensor in remote controller cooling	49
malfunction of thermostat sensor in remote controller	117	heating	50
malfunction of transmission between central remote controller and indoor unit.....	157, 161, 174	torque wrench.....	198
malfunction of transmission between indoor and outdoor units in the same system.....	153	turn power on.....	54
malfunction of transmission between indoor units and outdoor units	149	U unit no. transfer.....	96
malfunction of transmission between inverter and control pc board.....	141	W weigher for refrigerant charge.....	201
malfunction of transmission between main and sub remote controllers	152	wired remote controller	59
malfunction of transmission between optional controllers for centralized control	164, 177	wireless remote controller - indoor unit.....	60
malfunction of transmission between remote controller and indoor unit.....	151	wiring diagrams for reference indoor unit	187
O operation lamp blinks.....	168	outdoor unit	186
operation mode.....	28		
operation of the remote controller's inspection / test operation button.....	94		
P PC board defect.....	103, 118, 163, 176		
PC board layout (outdoor unit)	58		
pipng diagrams indoor unit	185		
outdoor unit	184		
power supply insufficient or instantaneous failure	146		
pressure sensor	192		
R refrigerant circuit.....	24		
refrigerant oil.....	199		
S self-diagnosis by wired remote controller	91		
set cool / heat separately for each outdoor system by indoor unit remote controller.....	76		
set cool / heat separately for each outdoor unit system by cool / heat switching remote controller	77		
setting of air flow direction adjustment range	65		

Warning



- Ask a qualified installer or contractor to install this product. Do not try to install the product yourself. Improper installation can result in water or refrigerant leakage, electrical shock, fire or explosion.
- Use only those parts and accessories supplied or specified by Daikin. Ask a qualified installer or contractor to install those parts and accessories. Use of unauthorized parts and accessories or improper installation of parts and accessories can result in water or refrigerant leakage, electrical shock, fire or explosion.
- Read the User's Manual carefully before using this product. The User's Manual provides important safety instructions and warnings. Be sure to follow these instructions and warnings.

For any inquiries, contact your local distributor.



© 2004 Daikin Industries, Limited.

Daikin®, Daikin AC™, Absolute Comfort™, VRV® and REFNET™ are trademarks pending or registered trademarks of Daikin Industries, Limited. All rights reserved. LonWorks® and LON® are registered trademarks of Echelon Corporation. BACnet® is a Data Communication Protocol for Building Automation and Control Networks, developed under the auspices of the American Society of Heating, Refrigerating and Air-Conditioning Engineers (ASHRAE).



The air conditioners manufactured by Daikin Industries have received **ISO 9001** certification for quality assurance.

Certificate Number. JMI-0107
JQA-0495
JQA-1452



All Daikin Industries locations and subsidiaries in Japan have received environmental management system standard **ISO 14001** certification.

Daikin Industries, Ltd. Domestic Group
Certificate Number. EC99J2044

About ISO 14001

ISO 14001 is the standard defined by the International Organization for Standardization (ISO) relating to environmental management systems. Our group has been acknowledged by an internationally accredited compliance organisation as having an appropriate programme of environmental protection procedures and activities to meet the requirements of ISO 14001.

Dealer

DAIKIN U.S. CORPORATION

1645 Wallace Drive, Suite 110
Carrollton, TX75006

info@daikinac.com
www.daikinac.com

©All rights reserved

●The specifications, designs, and information in this brochure are subject to change without notice.