

INSTALLER'S GUIDE

*DD-IN-2
18-CB15D3-1

Library	Service Literature
Product Section	Unitary
Product	Furnace — Gas
Model	*DD
Literature Type	Installer's Guide
Sequence	2
Date	August 1993
File No.	PL-UN-FURN-*DD-IN-2 8/93
Supercedes	New

**ALL phases of this installation must comply with
NATIONAL, STATE AND LOCAL CODES**

Model:

- *DD040C924B *DD100C948B
- *DD060C936B *DD100C960B
- *DD080C936B *DD120C960B
- *DD080C945B *DD140C960B
- *DD100C945B

* - First Letter May Be "A" or "T"

Downflow / Horizontal Gas-Fired Furnaces "Fan Assisted Combustion System"

IMPORTANT—This Document is customer property and is to remain with this unit. Please return to service information pack upon completion of work.

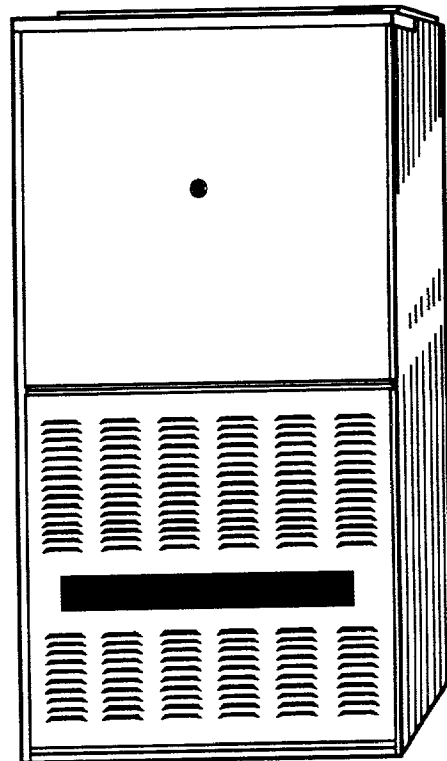
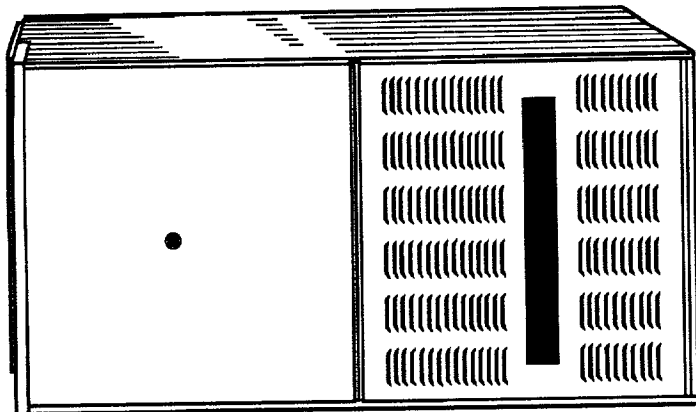

Since the manufacturer has a policy of continuous product improvement, it reserves the right to change specifications and design without notice.

INSTALLER'S GUIDE

CONTENTS	PAGE
INSTALLATION	
General Installation Instructions	2
Location & Clearances	2
Horizontal Installation	2
Air for Combustion and Ventilation	4
Duct Connections	5
Return Air — Filters	6
Venting	7
Venting Into a Masonry Chimney	7
Information and Vent Tables	8
Electrical Connections	17
Gas Piping	17
START-UP AND ADJUSTMENT	
Preliminary Inspections	18
Combustion and Input Check	18
High Altitude Derate	19
Sequence of Operation	19
Lighting Instructions	19
Control and Safety Switch Adjustment	20
OPERATING INFORMATION	
FIELD WIRING DIAGRAMS	
OUTLINE DRAWING	

GENERAL

The manufacturer assumes no responsibility for equipment installed in violation of any code or regulation.

It is recommended that Manual J of the Air Conditioning Contractors Association (ACCA) or A.R.I. 230 be followed in estimating heating requirements. When estimating heating requirements for installation at Altitudes above 2000 ft., remember the gas input must be reduced (See HIGH ALTITUDE DERATE).

Material in this shipment has been inspected at the factory and released to the transportation agency without known damage. Inspect exterior of carton for evidence of rough handling in shipment. Unpack carefully after moving equipment to approximate location. If damage to contents is found, report the damage immediately to the delivering agency.

Codes and local utility requirements governing the installation of gas fired equipment, wiring, plumbing, and flue connections must be adhered to. In the absence of local codes, the installation must conform with the National Fuel Gas Code ANSI Z223.1 "latest edition". The latest code may be obtained from the American Gas Association Laboratories, 8501 E. Pleasant Valley Rd., Cleveland, Ohio 44131.

These furnaces have been classified as Fan Assisted CATEGORY I furnaces as required by ANSI Z21.47 "latest edition" and therefore do not require any special provisions for venting other than what is indicated in these instructions.

NOTE: To prevent shortening its service life, the furnace should not be used as a "Construction Heater" during the finishing phases of construction. The low return air temperatures can lead to the formation of condensate even though this is a non-condensing model. Condensate in the presence of chlorides and fluorides from paint, varnish stains, adhesives, cleaning compounds, and cement create a corrosive condition which may cause rapid deterioration of the heat exchanger.

LOCATION AND CLEARANCES

The location of the furnace is normally selected by the architect, the builder, or the installer. However, before the furnace is moved into place, be sure to consider the following requirements:

1. Is the location selected as near the chimney or vent and as centralized for heat distribution as practical?
2. Do all clearances between the furnace and enclosure equal or exceed the minimums shown in the Clearance Table on Pg. 3.
3. Is there sufficient space for servicing the furnace and other equipment? A minimum of 24 inches front clearance to the furnace must be provided. Any access door or panel must permit removal of the largest component.
4. Are there at least 6 inches of clearance between the furnace combustion air openings in the front panel and any closed panel or door provided?
5. Are the ventilation and combustion air openings large enough and will they remain unobstructed? If outside air is used, are the openings set above the highest snow accumulation level? (See the Air for Combustion and Ventilation section)
6. Allow sufficient height in supply plenum below the furnace to provide for cooling coil installation, if the cooling coil is not installed at the time of this furnace installation.

The furnace must be installed in a location where all electrical components are protected from water.

If the furnace is installed in a **residential garage**, it must be installed so that the burners, and the ignition source are located not less than 18 inches above the floor and the furnace must be located or protected to avoid physical damage from vehicles.

CAUTION: Do not install the furnace in a corrosive or contaminated atmosphere.

WARNING: Do not install the furnace directly on carpeting, tile or other combustible material other than wood flooring. For downflow application, sub-base (BAYBASE205) must be used between the furnace and combustible flooring.

When the furnace is installed vertically with a cased coil, a sub-base is not required. Three brackets (with screws) are included for installation to stabilize and secure the furnace to the cased coil in the horizontal position.

The coil is reversed so that the bottom of the cased coil matches the bottom of the furnace for proper airflow. The brackets

CASED COIL
HORIZONTAL
CONNECTION
BRACKET

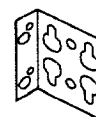

MINIMUM CLEARANCE FROM COMBUSTIBLE MATERIALS FOR DOWNFLOW / HORIZONTAL FURNACE

UNIT LOCATION	SURFACE	VENT TYPE	040, 060	080, 100, 120, 140
DOWNFLOW - CLOSET	SIDES	Single Wall (R)	3'	0'
		Single Wall (L)	0'	0'
		Type B1 (Double wall)	0'	0'
	BACK		0'	0'
	TOP		1"	1"
HORIZONTAL - CLOSET	FRONT	Single Wall	6'	6'
		Type B1 (Double wall)	6'	6'
	VENT	Single Wall	6'	6'
		Type B1 (Double wall)	1"	1"
	SIDES		1"	1"
BACK		3'	3'	
HORIZ. - ALCOVE / ATTIC	TOP	Single Wall (L)	*3"	2'
		Type B1 (Double wall)	2"	2"
	FRONT	Single Wall	6'	6'
		Type B1 (Double wall)	6'	6'
	VENT	Single Wall	6'	6'
Type B1 (Double wall)	1"	1"		
HORIZ. - ALCOVE / ATTIC	SIDES		0'	0'
			0'	0'
	TOP	Single Wall (L)	*3"	1"
		Type B1 (Double wall)	1"	1"
	FRONT		18"	18"
VENT	Single Wall	6'	6'	
Type B1 (Double wall)	1"	1"		

*Note: When the furnace is in the horizontal position, and the distance to the combustibile floor is governed by the type of the vent used, a 14-1/2" wide cabinet model installed on the right side (from the upright position), single wall vent may not be used if the floor is combustibile.

mount using the rear screws on the coil case and use the screws provided to secure the bracket to the furnace. The remaining bracket is centered horizontally between the coil case front and the furnace bottom channel. Use four screws provided to secure the bracket.

Required floor opening: (DOWNFLOW)

FIGURE 1

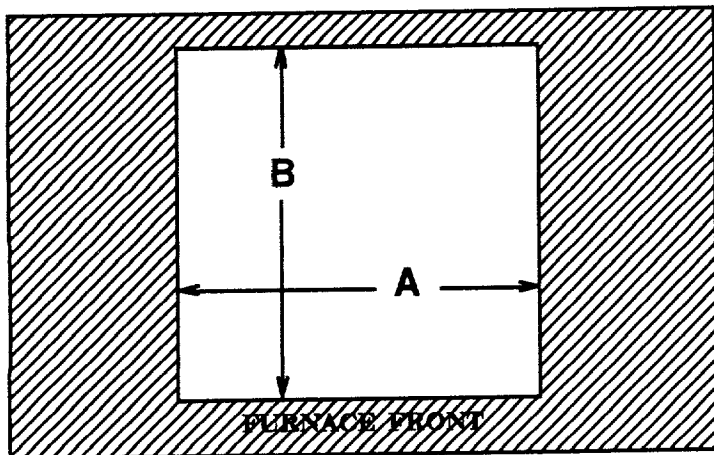

TABLE 1

CABINET WIDTH	RETURN DUCT WIDTH	FLOOR OPENING		PLENUM OPENING	
		"A"	"B"	"A"	"B"
14-1/2"	13-1/4"	13-5/8"	20-1/8"	12-5/8"	19-3/8"
17-1/2"	16-1/4"	16-5/8"	20-1/8"	15-5/8"	19-3/8"
21"	19-3/4"	20-1/8"	20-1/8"	19-1/8"	19-3/8"
24-1/2"	23-1/4"	23-5/8"	20-1/8"	22-5/8"	19-3/8"

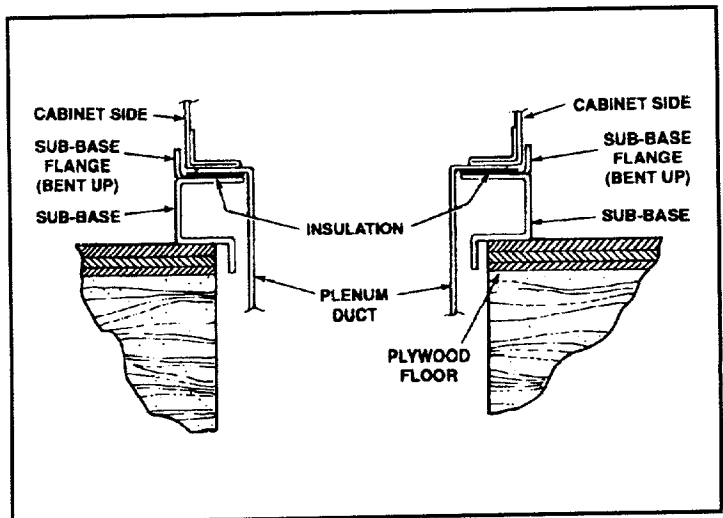

FIGURE 2

HORIZONTAL INSTALLATION

This furnace may be installed in an attic or crawl space in the horizontal position by placing the furnace on the left or right side (as viewed from the front in the upright position). The horizontal furnace installation in an attic should be on a service platform large enough to allow for proper clearances on all sides and service access to the front of the furnace, (See Clearance Table). Line contact is only permissible between lines formed by intersections of the top and two sides of the furnace casing and building joists, studs, or framing.

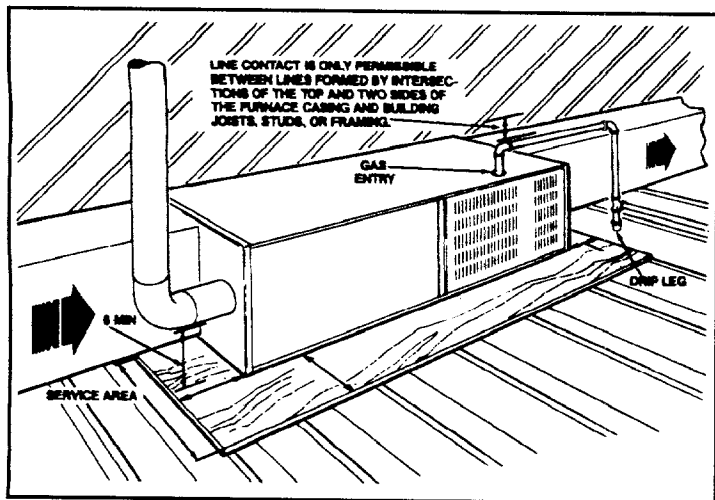

FIGURE 3

The furnace may be placed horizontally in a crawl space on a pad or other like non-combustible material which will raise the unit for sufficient protection from moisture. The horizontal furnace may also be suspended from the joists using four 3/8" all-thread rods with two pieces of angle iron underneath the furnace to form a hanging rack. The rods need to be of sufficient length to allow for proper clearances from combustible materials. The angle iron needs to be at least 32" in length to allow for access to service panels.

AIR FOR COMBUSTION AND VENTILATION

Adequate flow of combustion and ventilating air must not be obstructed from reaching the furnace. Air openings provided in the furnace casing must be kept free of obstructions which restrict the flow of air. Airflow restrictions affect the efficiency and safe operation of the furnace. Keep this in mind should you choose to remodel or change the area which contains your furnace. Furnaces must have a free flow of air for proper performance.

Provisions for combustion and ventilation air shall be made in accordance with Section 5.3, Air for Combustion and Ventilation, of the National Fuel Gas Code, ANSI Z223.1 "latest edition" or applicable provisions of the local building codes. Special conditions created by mechanical exhausting of air and fireplaces must be considered to avoid unsatisfactory furnace operation.

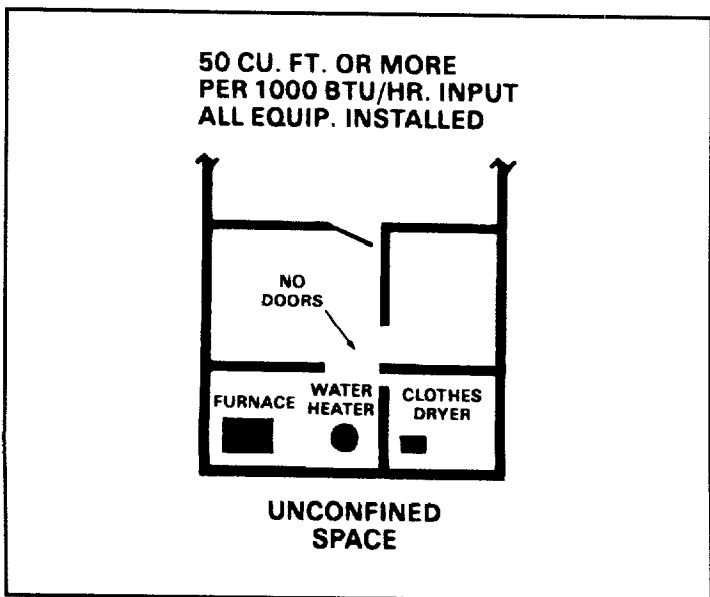

FIGURE 4

Table 2

MINIMUM AREA IN SQUARE FEET FOR UNCONFINED SPACE INSTALLATIONS

FURNACE MAXIMUM BTUH/INPUT RATING	WITH 8 FT. CEILING MINIMUM AREA IN SQUARE FEET OF UNCONFINED SPACE
40,000	250
60,000	375
80,000	500
100,000	625
120,000	750
140,000	875

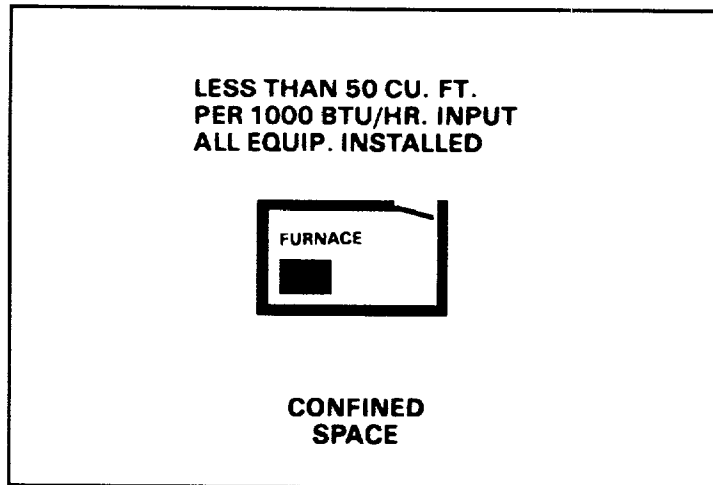

FIGURE 5

Furnace locations may be in "confined space" or "unconfined space". *Unconfined space* is defined in Tables 2 and Figure 4. These spaces may have adequate air by infiltration to provide air for combustion and ventilation. Buildings with tight construction (for example, weather stripping, heavily insulated, caulked, vapor barrier, etc.), additional air may need to be provided as described for *confined space*.

Confined spaces are installations with less than 50 cu. ft. of space per 1000 BTU/hr input from all equipment installed. Air for combustion and ventilation requirements can be supplied from inside the building as in Figure 6 or from the outdoors, as in Figure 7.

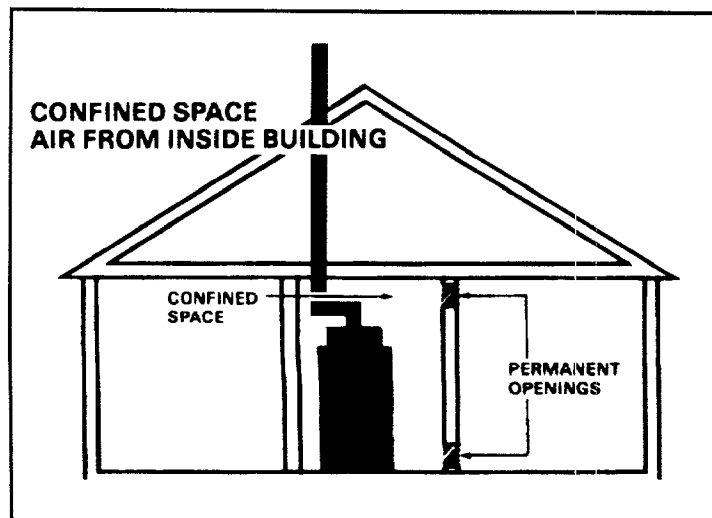

FIGURE 6

AIR FOR COMBUSTION AND VENTILATION

Table 3
MINIMUM FREE AREA IN SQ. INCHES
EACH OPENING (FURNACE ONLY)

Furnace Maximum BTUH/INPUT Rating	Air From Inside	Air From Outside	
		Vertical Duct	Horizontal Duct
40,000	100	10	20
60,000	100	15	30
80,000	100	20	40
100,000	100	25	50
120,000	120	30	60
140,000	140	35	70

1. All air from inside the building as in Figure 6: The confined space shall be provided with two permanent openings communicating directly with an additional room(s) of sufficient volume so that the combined volume of all spaces meets the criteria for an unconfined space. The total input of all gas utilization equipment installed in the combined space shall be considered in making this determination. Refer to Table 3 for minimum open areas required.

2. All air from outdoors as in Figure 7: The confined space shall be provided with two permanent openings, one commencing within 12 inches of the top and one commencing within 12 inches of the bottom of the enclosure. The openings shall communicate directly, or by ducts, with the outdoors or spaces (crawl or attic) that freely communicate with the outdoors. Refer to Table 3, for minimum open areas required.

3. The following types of installations will **require** use of **OUTDOOR AIR** for combustion, due to chemical exposures:

- * Commercial buildings
- * Buildings with indoor pools
- * Furnaces installed in commercial laundry rooms
- * Furnaces installed in professional hobby or craft rooms
- * Furnaces installed near chemical storage areas.

Exposure to the following substances in the combustion air supply will also require **OUTDOOR AIR** for combustion:

- * Permanent wave solutions
- * Chlorinated waxes and cleaners
- * Chlorine based swimming pool chemicals
- * Water softening chemicals
- * De-icing salts or chemicals
- * Carbon Tetrachloride
- * Halogen type refrigerants
- * Cleaning solvents (such as perchloroethylene)
- * Printing inks, paint removers, varnish, etc.
- * Hydrochloric acid
- * Cements and glues
- * Anti-static fabric softeners for clothes dryers
- * Masonry acid washing materials

DUCT CONNECTIONS

Air duct systems should be installed in accordance with standards for air conditioning systems, National Fire Protection Association Pamphlet No. 90. They should be sized in accordance with ACCA Manual D or whichever is applicable. Check on controls to make certain they are correct for the electrical supply.

Central furnaces, when used in connection with cooling units, shall be installed in parallel or on the upstream side of the cooling units to avoid condensation in the heating element, unless the furnace has been specifically approved for *downstream installation*. With a parallel flow arrangement, the dampers or other means used to control flow of air shall be adequate to prevent chilled air from entering the furnace, and

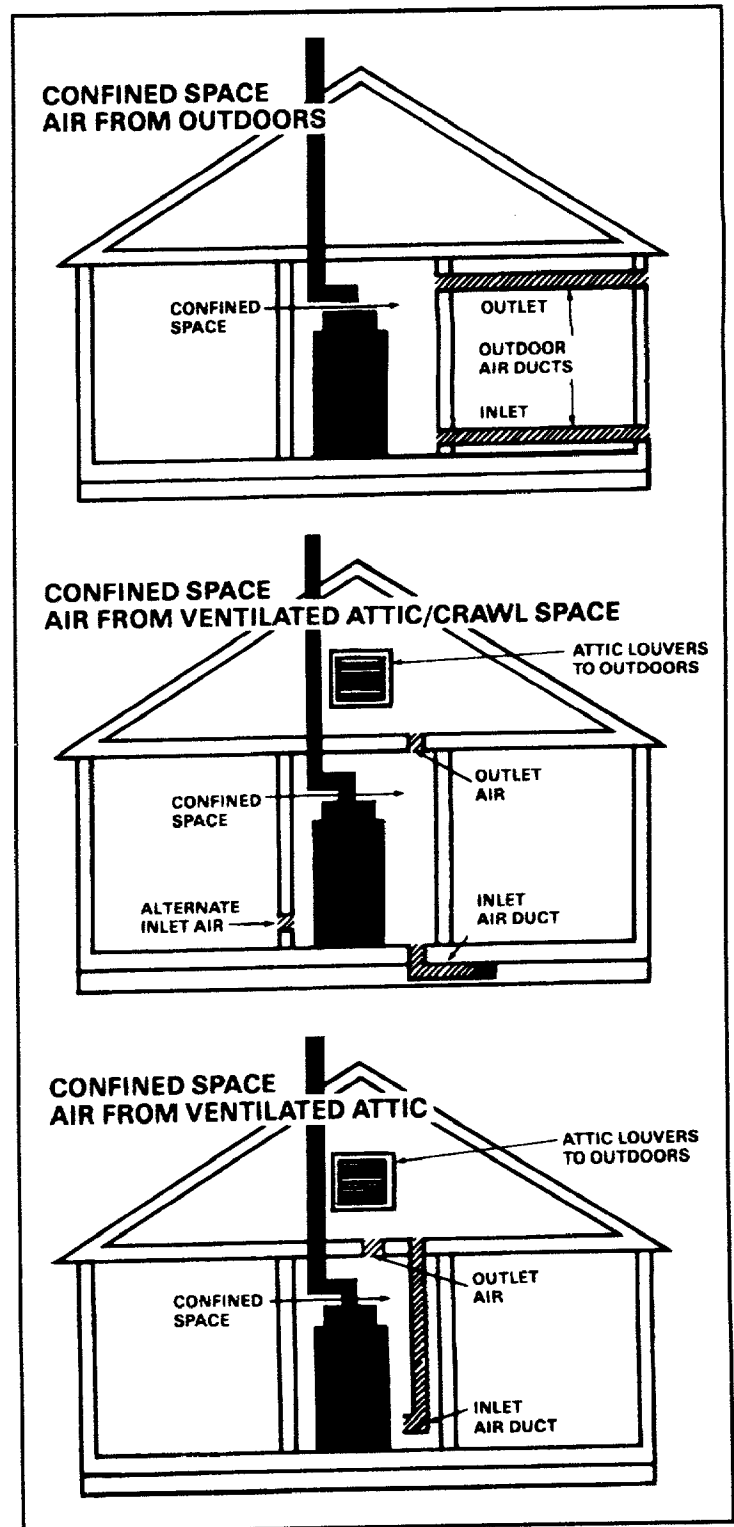

FIGURE 7

if manually operated, must be equipped with means to prevent operation of either unit unless the damper is in full heat or cool position.

On any job, flexible connections of non-flammable material may be used for return air and discharge connections to prevent transmission of vibration. Though these units have been specifically designed for quiet, vibration free operation, air ducts can act as sounding boards and could, if poorly installed, amplify the slightest vibration to the annoyance level.

Where the furnace is located in a utility room adjacent to the living area, the system should be carefully designed with returns to minimize noise transmission through the return air

grille. Although these furnaces are designed with large blowers operating at moderate speeds, any blower moving a high volume of air will produce audible noise which could be objectionable when the unit is located very close to a living area. It is often advisable to route the return air ducts under the floor or through the attic. Such design permits the installation of air return remote from the living area (i.e. central hall).

When the furnace is installed so that the supply ducts carry air circulated by the furnace to areas outside the space containing the furnace, the return air shall also be handled by a duct(s) sealed to the furnace and terminating outside the space containing the furnace.

Where there is no complete return duct system, the return connection must be run full size from the furnace to a location outside the utility room, basement, attic, or crawl space.

Do Not install return air through the back of the furnace cabinet.

RETURN AIR DUCT CONNECTION

All return air duct systems should provide for installation of return air filters.

1. Set the furnace in place.
2. Connect duct work to furnace. See Outline Drawing for supply and return duct size and location. Flexible duct connectors are recommended to connect both supply and return air ducts to the furnace. If only the front of the furnace is accessible, it is recommended that both supply and return air plenums are removable.
3. When replacing a furnace, old duct work should be cleaned out. Thin cloths should be placed over the registers and the furnace fan should be run for 10 minutes. Don't forget to remove the cloths before you start the furnace.

RETURN AIR FILTERS

Furnaces are factory supplied with high velocity cleanable type air filters which are located within the furnace blower compartment.

After the return air plenum has been connected to the furnace in either downflow or horizontal position the return air filters may be installed in the plenum using the brackets (and screws) supplied with the furnace. See Table 4. Although some units are wide enough to access the filters by reaching up through the blower compartment, it is recommended that a filter access opening be cut in the return air plenum. See Figure 8, Figure 9, and Table 5 for typical installation. A filter access door will need to be made to cover this opening. The door should be one inch larger in both dimensions to provide an overlap of the opening. Use foam backed tape to make a gasket around the access opening.

TABLE 4

CABINET WIDTH	FILTER SIZE	FILTER BRACKET LOCATION *
14-1/2"	2 - 14X20X1	12-7/8"
17-1/2"	2 - 14X20X1	14-3/8"
21"	2 - 16X20X1	13-1/8"
24-1/2"	2 - 16X20X1	11-5/8"

* Location dimension is from end of duct to the screw holes for the bracket.

To replace filters, remove the filter access door, lift the filter from the lower bracket and shift the filter to the side to free the top bracket and slide the filter out through the filter access door. Replace the filters in the same manner, making sure that the filter is secured in both top and bottom brackets. Replace the filter access door. **Use high velocity replacement filters only.**

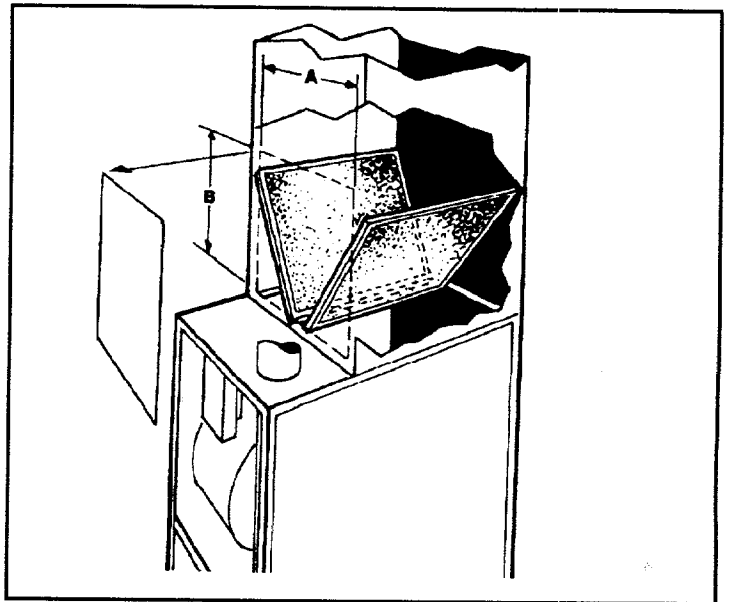

FIGURE 8

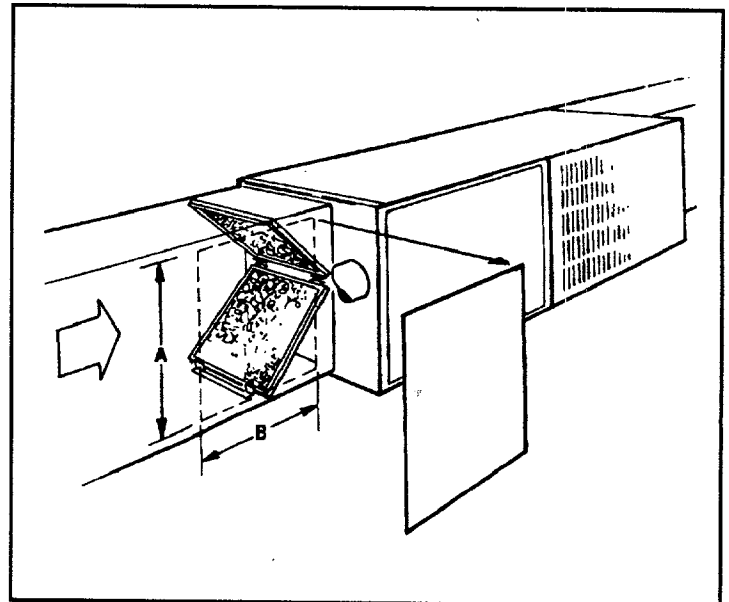

FIGURE 9

TABLE 5

CABINET WIDTH	RETURN DUCT WIDTH	FILTER ACCESS OPENING - DIMENSION "A"	FILTER ACCESS OPENING - DIMENSION "B"
14-1/2"	13-1/4"	12"	14"
17-1/2"	16-1/4"	15"	14"
21"	19-3/4"	19-1/2"	14"
24-1/2"	23-1/4"	22"	14"

VENT PIPING

The *DD-C series furnaces have been classified as Fan Assisted Category I furnaces under the provisions of ANSI Z21.47 "latest edition" standards, to operate under conditions with a non-positive pressure vent and flue gas temperatures at least 140°F above its dew point.

NOTE: When an existing furnace is removed from a venting system serving other appliances, the venting system is likely to be too large to properly vent the remaining attached appliances. The following steps shall be followed with each appliance remaining connected to the common venting system placed in operation, while the other appliances remaining connected to the common system are in operation:

- a. Seal any unused openings in the common venting system.
- b. Visually inspect the venting system for proper size and horizontal pitch. Determine there is no blockage or restriction, leakage, corrosion or other deficiencies which could cause an unsafe condition.
- c. Insofar as is practical, close all building doors and windows and all doors between the space in which the appliances remaining connected to the common venting system are located and other spaces of the building. Turn on clothes dryers and any appliances not connected to the common venting system. Turn on any exhaust fans, such as range hoods and bathroom exhausts, so they will operate at maximum speed. Do not operate a summer exhaust fan. Close fireplace dampers.
- d. Follow the lighting instructions. Place the appliance being inspected in operation. Adjust thermostat so the appliance will operate continuously.
- e. Test for spillage at the draft hood relief opening after 5 minutes of main burner operation. Use the flame of a match or candle, or smoke from a cigarette, cigar, or pipe.
- f. After it has been determined that each appliance remaining connected to the common venting system properly vents when tested as outlined above, return doors, windows, exhaust fans, fireplace dampers and any other gas-burning appliance to their previous condition of use.
- g. If improper venting is observed during any of the above tests, the common venting system must be corrected according to the standards set forth in National Fuel Gas Code, ANSI Z223.1.

All vent installations must be in accordance with the provisions of the National Fuel Gas Code, ANSI Z223.1 "latest edition" section 7, and/or any applicable local codes.

The furnace shall be connected to a factory built chimney or vent complying with a recognized standard, or a masonry or concrete chimney lined with a lining material acceptable to the authority having jurisdiction.

MASONRY CHIMNEY VENTING

Type Furnace	Tile Lined Chimney		Chimney Lining	
	Internal	External	"B" Vent	Flexible Metal Liner
Single Fan Assist	No	No	Yes	*Yes
Fan Assist + Fan Assist	No	No	Yes	*Yes
Fan Assist + Natural	Yes	No	Yes	*Yes

* Flexible chimney liner size is determined by using the type "B" vent size for the available BTUH input, then reducing the maximum capacity by 20% (multiply maximum capacity times 0.80). The minimum capacity is the same as shown in the "B" vent tables.

VENTING INTO A MASONRY CHIMNEY

If the chimney is oversized, the liner is inadequate, or flue-gas condensation is a problem in your area, consider using the chimney as a pathway or chase for type "B" vent or flexible vent liner. If flexible liner material is used, size the vent using the "B" vent tables, then reduce the maximum capacity by 20% (multiply 0.80 times the maximum capacity).

Internal Masonry Chimneys

Venting of fan assisted appliances into a lined, internal masonry chimney is allowed only if it is common vented with at least one natural draft appliance; **OR**, if the chimney is lined with type "B", double wall vent or suitable flexible liner material, (See preceding table). The chimney liner must be thoroughly inspected to insure no cracks or other potential areas for flue gas leaks are present in the liner. Liner leaks will result in early deterioration of the chimney.

External Masonry Chimney

Venting of fan assisted appliances into external chimneys (one or more walls exposed to outdoor temperatures), requires the chimney be lined with type "B", double wall vent or suitable flexible chimney liner material. This applies in all combinations of common venting as well as for fan assisted appliances vented alone.

NOTE: Unlined chimneys are not approved for furnace venting.

The following installation practices are recommended to minimize corrosion caused by condensation of flue products in the furnace and flue gas system.

1. Avoid an excessive number of bends.
2. Horizontal runs should pitch upward at least 1/4" per foot.
3. Horizontal runs should be as short as possible.
4. All vent pipe or connectors should be securely supported and must be inserted into, but not beyond the inside wall at the chimney vent.
5. When vent connections must pass through walls or partitions of combustible material, a thimble must be used and installed according to local codes.
6. Vent pipe through the roof should be extended to a height determined by National Fuel Gas Code or local codes. It should be capped properly to prevent rain water from entering the vent. Roof exit should be waterproofed.
7. Use type "B" double wall vent when vent pipe is routed through cool spaces.
8. If single-wall connectors are used in cool spaces (below 60°F), they should be insulated to prevent condensation.
9. Where long periods of airflow are desired for comfort, use long fan cycles instead of continuous airflow.
10. Apply other good venting practices as stated in the venting section of the National Fuel Gas Code ANSI Z223.1 "latest edition".

11. Vent connectors serving appliance vented by natural draft or non-positive pressure shall not be connected into any portion of a mechanized draft system operating under positive pressure.

12. Horizontal pipe runs must be supported by hangers, straps or other suitable material in intervals at a minimum of every 3 feet of pipe.

13. A furnace shall not be connected to a chimney or flue serving a separate appliance designed to burn solid fuel.

INSTALLER'S GUIDE

SIZING OF VENTING SYSTEMS SERVING APPLIANCES EQUIPPED WITH DRAFT HOODS AND APPLIANCES LISTED FOR USE WITH TYPE B VENTS

DEFINITION OF TERMS

"Fan Assisted Combustion System"

An appliance equipped with an integral mechanical means to either draw or force products of combustion through the combustion chamber and/or heat exchanger.

"FAN Min"

Refers to the minimum appliance input rating of a Category I appliance with a fan-assisted combustion system that could be attached to the vent.

"FAN Max"

Refers to the maximum appliance input rating of a Category I appliance with a fan-assisted combustion system that could be attached to the vent.

"NAT Max"

Refers to the maximum appliance input rating of a Category I appliance equipped with a draft hood that could be attached to the vent. There are no minimum appliance input ratings for draft hood equipped appliances.

"FAN+FAN"

Refers to the maximum combined input rating of two fan-assisted appliances attached to the common vent.

"FAN+NAT"

Refers to the maximum combined input rating of one fan-assisted appliance and one draft hood equipped appliance attached to the common vent.

"NAT+NAT"

Refers to the maximum combined input rating of two draft hood equipped appliances attached to the common vent.

"NR"

Means not recommended due to potential for condensate formation and/or pressurization of the venting system.

"NA"

Means not applicable due to physical or geometric constraints.

GENERAL VENTING REQUIREMENTS

All requirements contained in these instructions apply to CATEGORY I fan-assisted appliances. At no time should a venting system for a listed CATEGORY II, III, OR IV appliance be sized using these tables. At this time, alternate sizing methods have not been developed for fan-assisted appliances. Therefore, until engineering data is developed to allow alternate sizing methods for CATEGORY I fan-assisted appliances, the following vent tables must be used.

1. The venting tables included in this instruction apply to vents and chimneys internal to the structure below the roof line. These tables are not applicable to outside chimneys or vents unless enclosed in a chase. A Type B vent passing through an unused masonry chimney is considered to be an enclosed vent system and these tables may be used.

2. If the vent size determined from the tables is smaller than the appliance flue collar, the smaller size may be used provided:

- a. The total vent height is at least 10 feet.
- b. Vents for appliance draft hood outlets or flue collars 12 inches in diameter or smaller are not reduced more than one size (e.g. 12 inches to 10 inches is a one size reduction).
- c. The maximum capacity listed in the tables for a fan-assisted appliance is reduced by 10% (0.90 x maximum capacity).

3. Single appliance venting configurations with zero lateral lengths, Vent Tables 7 & 8, are assumed to have no elbows in the vent system. For all other vent configurations with indicated lateral lengths, the vent system is assumed to have two 90°

elbows. For each additional 90° elbow, or equivalent beyond two, the maximum capacity listed in the venting table should be reduced by 10% (0.90 x maximum listed capacity).

4. The common venting Vent Table 9 & 10 were generated using a maximum vent connector length of 18 inches (one and one half feet) for each inch of connector diameter as follows:

CONNECTOR DIAMETER (INCHES)	MAXIMUM CONNECTOR LENGTH (FEET)
3	4 1/2
4	6
5	7 1/2
6	9
7	10 1/2
8	12
9	13 1/2
10	15

The vent connector should be routed to the vent utilizing the shortest possible route.

5. If vent connectors are combined prior to entering the common vent, the maximum common vent capacity listed in the common venting tables must be reduced by 10% (0.90 x maximum common vent capacity). See Figure 15. The length of the common vent connector offset (Lo) should not exceed 18 inches (one and one half feet) for each inch of common vent connector diameter.

6. If the common vertical vent is offset as shown in Figure 16, the maximum common vent capacity listed in the common venting tables should be reduced by 20% (0.80 x maximum common vent capacity).

7. The common vent diameter must always be at least as large as the largest vent connector diameter. All interconnection fittings must also be the same size as the common vent.

8. Listed gas venting systems using listed vent caps 12" and smaller in size may terminate in accordance with the GAS VENT TERMINATION - Table 6 and Figure 10.

9. Use sea level input rating when determining maximum capacity for high altitude installation. Use actual input rating for determining minimum capacity for high altitude installations.

10. No portion of the venting system can extend into, or pass through any circulating air duct or plenum.

11. All vent pipe passing through floors, walls, and ceilings must be installed with the listed clearance to combustible materials and be fire stopped according to local codes. In the absence of local codes, refer to the National Fuel Gas Code.

12. Vent connectors serving CATEGORY I appliances shall not be connected to any portion of mechanical draft systems operating under positive pressure such as CATEGORY III OR IV Venting Systems.

13. A CATEGORY I appliance must never be connected to a chimney that is servicing a solid fuel appliance. If a fireplace chimney, lined with a metal liner, is used to vent this appliance, the fireplace opening must be permanently sealed.

14. A vent connector shall be supported without dips or sags and shall slope a minimum of 1/4 inch per lineal foot of connector, back toward the furnace.

15. Vent connectors shall be firmly attached to draft hood outlets or flue collars by sheet-metal screws or other approved means, except vent connectors of listed Type B vent material which shall be assembled in accordance with the manufacturers instructions. Joints between sections of connector piping shall be fastened by sheet-metal screws or other approved methods.

16. When the vent connector used for CATEGORY I appliances must be located in or pass through a crawl space or other area which may be cold, that portion of the vent connector shall be of listed double-wall Type B vent material or material having equivalent insulation qualities.

17. The entire length of a vent connector shall be readily accessible for inspection, cleaning, and replacement.

18. For appliances with more than one input rate, the minimum vent or connector (Fan Min) capacity determined from the tables shall be less than the lowest appliance input rating and the maximum vent or connector (Fan Nat Max.) capacity determined from the tables shall be greater than the highest appliance input rating.

19. The flow area of the largest section of vertical vent or chimney shall not exceed 7 times the smallest listed appliance categorized vent area, flue collar area, or draft hood outlet area unless designed in accordance with approved engineering methods.

$$\text{Maximum Vent or Tile Lined Chimney Flow Area} = \frac{\pi (D^*)^2}{4} \times 7$$

*Draft hood outlet diameter, flue collar diameter, or listed appliance categorized vent diameter.

20. Masonry chimneys used to vent Category I central furnaces must be either tile-lined with a listed metal lining system of dedicated gas vent. Unlined masonry chimneys are prohibited.

21. A fan assisted furnace may be common vented into an existing masonry chimney provided:

a. The chimney is currently serving at least one draft hood equipped appliance.

b. The vent connectors and chimney are sized in accordance with Tables 13 & 14.

SINGLE APPLIANCE VENTING OF A FAN ASSISTED FURNACE INTO A TILE LINED, MASONRY CHIMNEY IS PROHIBITED. THE CHIMNEY MUST FIRST BE LINED WITH EITHER TYPE B VENT SIZED IN ACCORDANCE WITH TABLES 7 OR 8 OR A LISTED, SINGLE WALL, METAL LINING SYSTEM, SIZED IN ACCORDANCE WITH NOTE 22 BELOW.

22. Listed, corrugated metallic chimney lined systems in masonry chimneys shall be sized using Tables 7 or 8 for dedicated venting and Tables 9 or 10 for common venting with the maximum capacity reduced by 20% (.80 times maximum capacity) and the minimum capacity as shown in the applicable table. Corrugated metal vent systems installed with bends or offsets require additional reduction of the vent capacity (See #6)

23. For multiple units of gas utilization equipment all located on one floor, available total height "H" is measured from the highest draft hood outlet or flue collar up to the level of the cap or terminal. Connector rise "R" is measured from the draft hood outlet or flue collar to the level where the vent gas streams come together. (Not applicable to multi-story)

24. For multi-story installations, available total height for each segment of the system "H" is the vertical distance between the highest draft hood outlet or flue collar entering that segment and the centerline of the next higher interconnection tee.

25. The size of the lowest connector and of the vertical vent leading to the lowest interconnection of a multi-story system must be in accordance with Table 7 OR 8, for available total height "H" up to the lowest interconnection.

26. Common vents in multi-story systems shall be Type B and have no offsets.

27. Numbers followed by an asterisk (*) in Table 12, indicate the possibility of continuous condensation, depending on locality. Consult with local gas supplier or authority having jurisdiction.

28. In a single run of vent or vent connector, more than one diameter and type or pipe are permitted to be used, provided that all the sizes are permitted in the tables.

29. If the desired vent height and connector rise and/or lateral are between the table entries, linear interpolation is permitted for calculation of the permissible appliance input ratings. Extrapolation beyond the table entries is not recommended.

30. All combinations of pipe sizes, single-wall, and double-wall metal pipe are allowed within any connector run(s) or within the common vent provided ALL of the appropriate tables permit ALL of the desired sizes and types of pipe, as if they were used for the entire length of the subject connector or vent. If single-wall and Type B double-wall metal pipe are used for vent connectors, the common vent must be sized using Table 10.

31. Locate draft hood outlet or flue collar of smallest input appliance closet to or under common vent.

32. When vent table permits more than one diameter of pipe to be used for a connector or vent, the smallest permitted diameter should be preferred.

**TABLE 6
GAS VENT TERMINATION**

ROOF PITCH	MINIMUM HEIGHT
FLAT TO 7/12	1.0 FEET *
OVER 7/12 TO 8/12	1.5 FEET
OVER 8/12 TO 9/12	2.0 FEET
OVER 9/12 TO 10/12	2.5 FEET
OVER 10/12 TO 11/12	3.25 FEET
OVER 11/12 TO 12/12	4.0 FEET
OVER 12/12 TO 14/12	5.0 FEET
OVER 14/12 TO 16/12	6.0 FEET
OVER 16/12 TO 18/12	7.0 FEET
OVER 18/12 TO 20/12	7.5 FEET
OVER 20/12 TO 21/12	8.0 FEET

* THIS REQUIREMENT COVERS MOST INSTALLATIONS

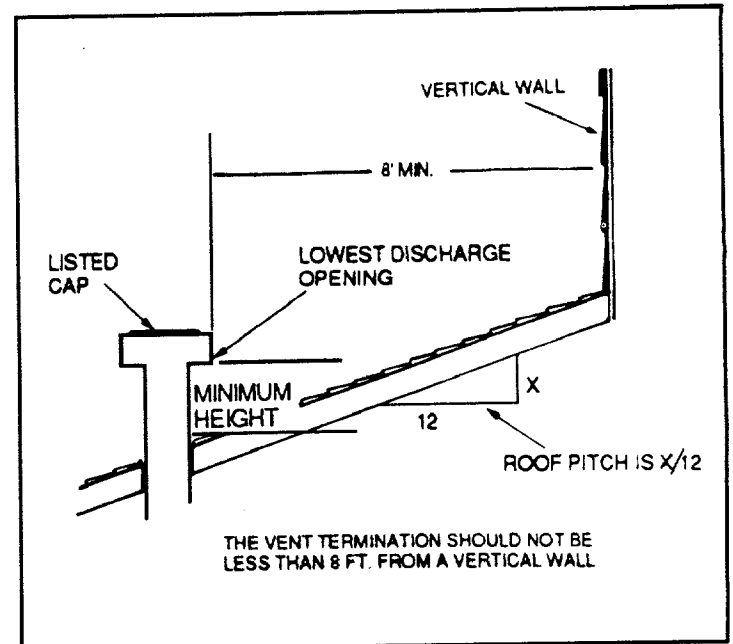

FIGURE 10

TYPICAL VENTING APPLICATIONS

Table 7 should be used when Type B vent is used for both the vent connector and the vertical vent.

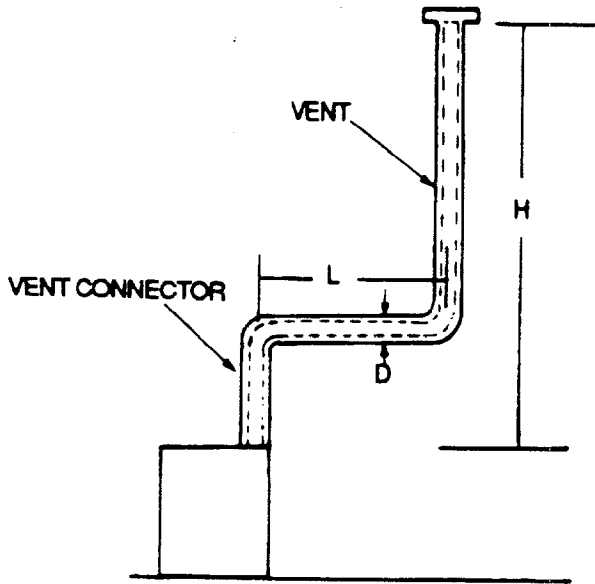

FIGURE 11

Table 8 should be used when a single-wall metal vent connector is attached to Type B vertical vent.

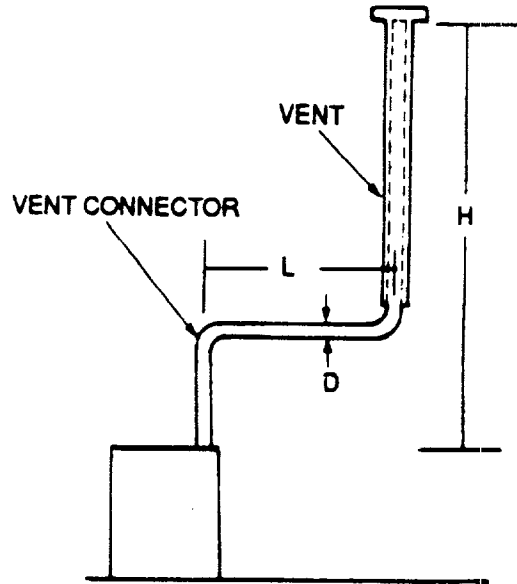

FIGURE 12

Table 9 should be used when Type B vent connectors are attached to a Type B common vent.

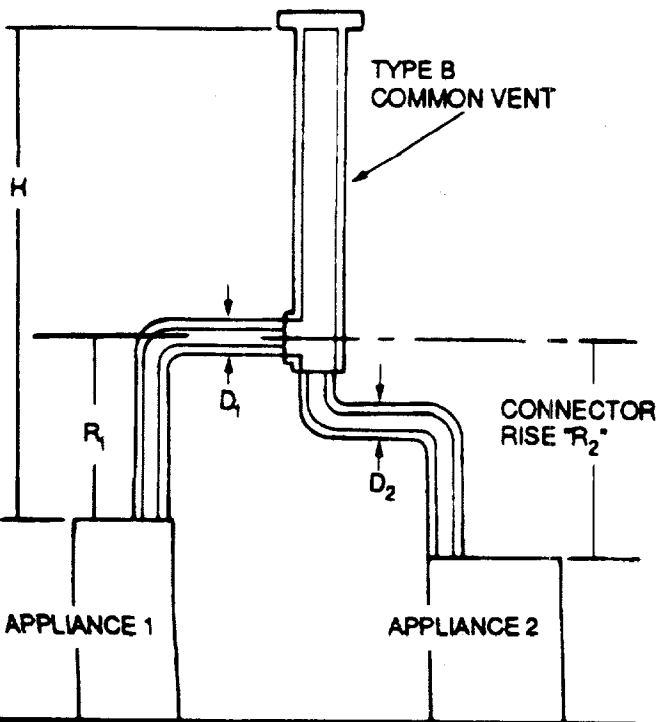

FIGURE 13

Table 10 should be used when single-wall metal vent connectors are attached to a Type B common vent.

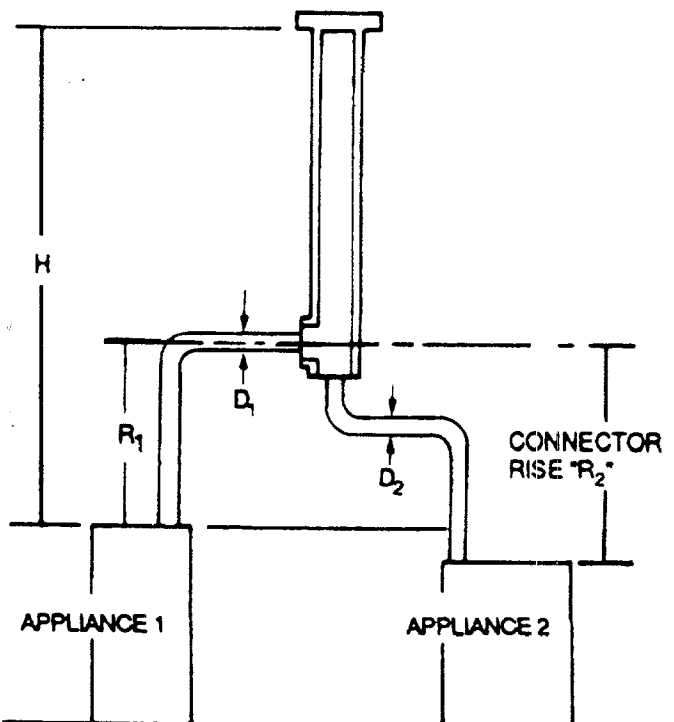

FIGURE 14

TYPICAL VENTING APPLICATIONS (Cont.)

Schematic Diagram showing a typical manifolded common vent section "L" of the vent connector. (See Note 5)

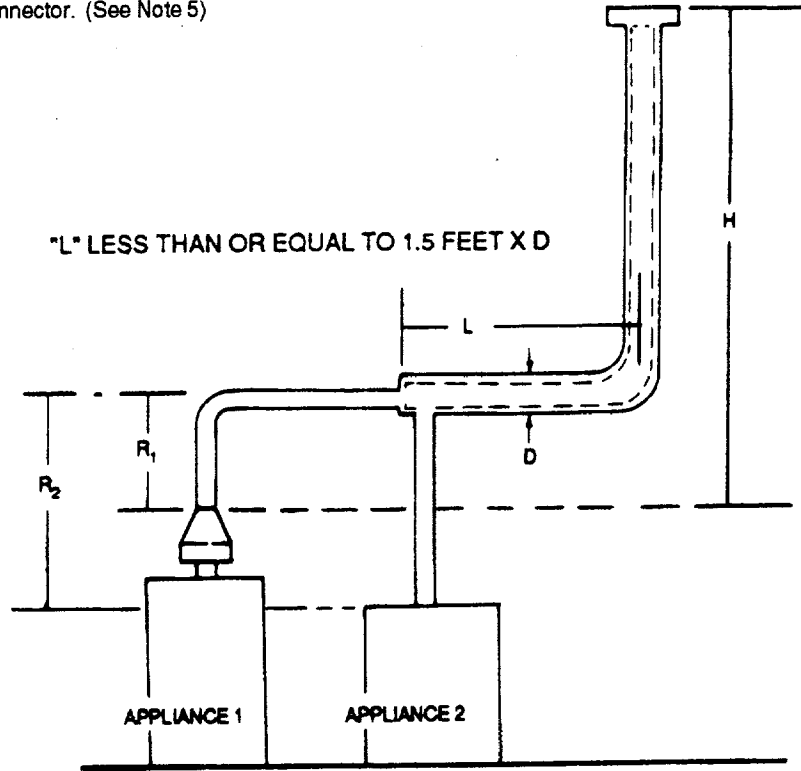

FIGURE 15

Schematic Diagram showing the offset in the common vent section of the vertical vent. (See Note 6)

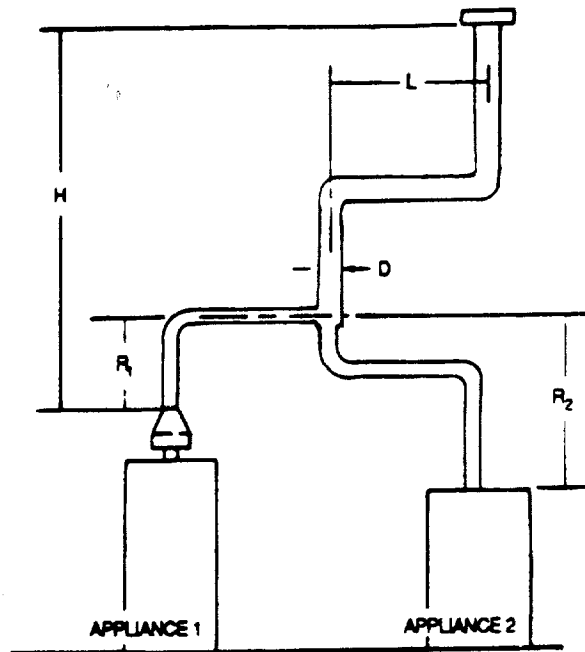

FIGURE 16

TYPICAL VENTING APPLICATIONS (Cont.)

Table 11 shall be used when a Type B, double-wall vent connector is attached to a tile lined masonry chimney.

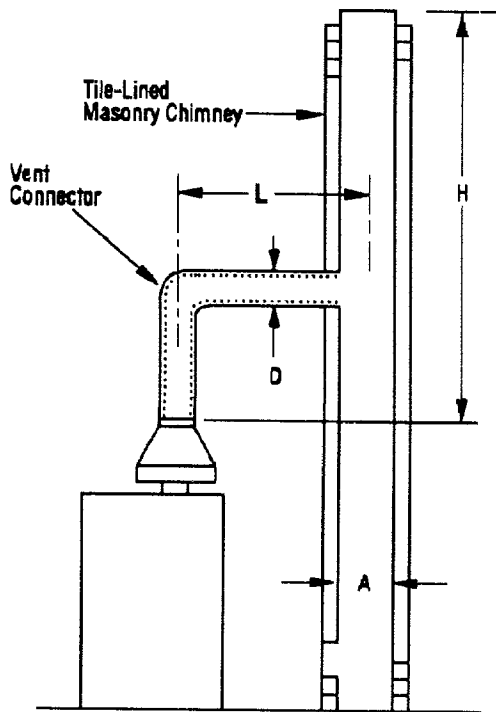

FIGURE 17

Table 12 shall be used when a single-wall metal vent connector is attached to a tile lined masonry chimney.

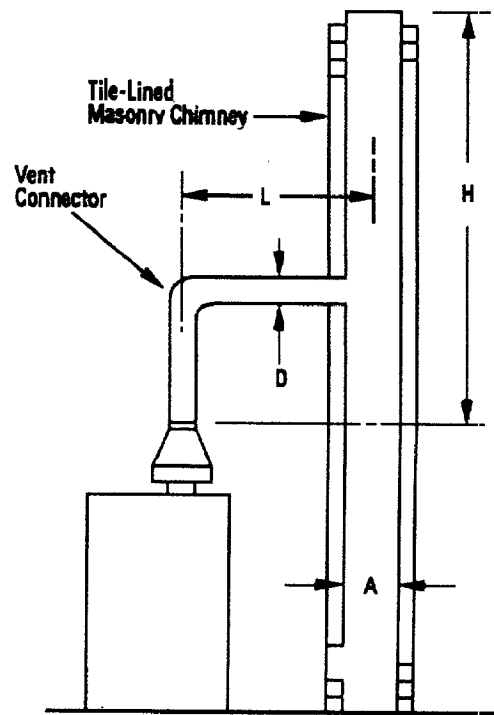

FIGURE 18

Table 13 shall be used when Type B double-wall vent connectors are attached to a tile lined masonry chimney.

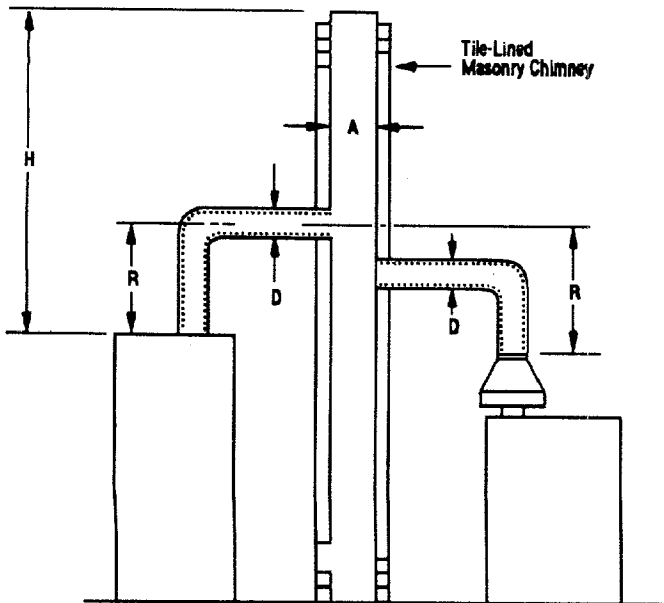

FIGURE 19

Table 14 shall be used when single-wall metal vent connectors are attached to a tile lined masonry chimney.

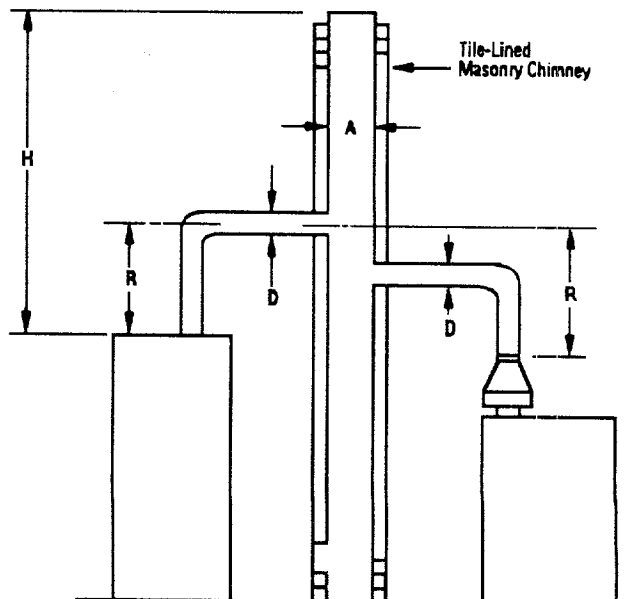

FIGURE 20

TABLE 7

Height H (ft)	Lateral L (ft)	Vent Connector Diameter - D (inches)											
		3"			4"			5"			6"		
		Appliance Input Rating in Thousands of Btu Per Hour											
		FAN		NAT	FAN		NAT	FAN		NAT	FAN		NAT
Min	Max	Max	Min	Max	Max	Min	Max	Max	Min	Max	Max		
6	0	0	78	46	0	152	86	0	251	141	0	375	205
2	2	13	51	36	18	97	67	27	157	105	32	232	157
4	4	21	49	34	30	94	64	39	153	103	50	227	153
6	6	25	46	32	36	91	61	47	149	100	59	223	149
8	0	0	84	50	0	165	94	0	276	155	0	415	235
2	2	12	57	40	16	109	75	25	178	120	28	263	180
5	5	23	53	38	32	103	71	42	171	115	53	255	173
8	8	28	49	35	39	98	66	51	164	109	64	247	165
10	0	0	88	53	0	175	100	0	295	166	0	447	255
2	2	12	61	42	17	118	81	23	194	129	26	289	195
5	5	23	57	40	32	113	77	41	187	124	52	280	188
10	10	30	51	36	41	104	70	54	176	115	67	267	175
15	0	0	94	58	0	191	112	0	327	187	0	502	285
2	2	11	69	48	15	136	93	20	226	150	22	339	225
5	5	22	65	44	30	130	87	39	219	142	49	330	217
10	10	29	59	42	40	121	82	51	206	135	64	315	208
15	15	35	53	39	48	112	76	61	195	128	76	301	198
20	0	0	97	61	0	202	119	0	349	202	0	540	307
2	2	10	75	51	14	149	100	18	250	166	20	377	249
5	5	21	71	48	29	143	96	38	242	160	47	367	241
10	10	28	64	44	38	133	89	50	229	150	62	351	228
15	15	34	58	40	46	124	84	59	217	142	73	337	217
20	20	48	52	35	55	116	78	69	206	134	84	322	206
30	0	0	100	64	0	213	128	0	374	220	0	587	336
2	2	9	81	56	13	166	112	14	283	185	18	432	280
5	5	21	77	54	28	160	108	36	275	176	45	421	273
10	10	27	70	50	37	150	102	48	262	171	59	405	261
15	15	33	64	NR	44	141	96	57	249	163	70	389	249
20	20	56	58	NR	53	132	90	66	237	154	80	374	237
30	30	NR	NR	NR	73	113	NR	88	214	NR	104	346	219
50	0	0	101	67	0	216	134	0	397	232	0	633	363
2	2	8	86	61	11	183	122	14	320	206	15	497	314
5	5	20	82	NR	27	177	119	35	312	200	43	487	308
10	10	26	76	NR	35	168	114	45	299	190	56	471	298
15	15	59	70	NR	42	158	NR	54	287	180	66	455	288
20	20	NR	NR	NR	50	149	NR	63	275	169	76	440	278
30	30	NR	NR	NR	69	131	NR	84	250	NR	99	410	259

EXAMPLE 1

Suppose an installer has an 80,000 Btu/hr input fan-assisted appliance that must be installed using 10 feet of lateral connector to a 30-Ft high Type B vent. Two 90° elbows are needed for the installation. Can a single-wall metal vent connector be used for this application?

SOLUTION

Table 8 refers to the use of single-wall metal vent connectors with Type B vent. In the first column find the row associated with a 30-Ft height and a 10-Ft lateral. Read across this row, looking at the "FAN Min" and "FAN Max" columns, to find that a 3 inch diameter single-wall metal connector vent is not recommended. Moving to the next larger size single-wall connector (4"), we find that a 4 inch diameter single-wall metal connector has a recommended minimum vent capacity of 91,000 Btu/hr and a recommended maximum vent capacity of 144,000 Btu/hr. The 80,000 Btu/hr fan-assisted appliance is outside the range, so we conclude that a single-wall metal vent connector cannot be used to vent this appliance using 10 feet of lateral for the connector.

However, we see that if the 80,000 Btu/hr input appliance could be moved to within 5 feet of the vertical vent, then a 4 inch single-wall metal connector could be used to vent the appliance. Table 8 shows the acceptable range of vent capacities for a 4 inch vent with 5 feet of lateral to be between 72,000 Btu/hr and 157,000 Btu/hr.

TABLE 8

Height H (ft)	Lateral L (ft)	Vent Connector Diameter - D (inches)											
		3"			4"			5"			6"		
		Appliance Input Rating in Thousands of Btu Per Hour											
		FAN		NAT	FAN		NAT	FAN		NAT	FAN		NAT
Min	Max	Max	Min	Max	Max	Min	Max	Max	Min	Max	Max		
6	0	38	77	45	59	151	85	85	249	140	126	373	204
2	2	39	51	36	60	96	66	85	156	104	123	231	156
4	4	NR	NR	33	74	92	63	102	152	102	146	225	152
6	6	NR	NR	31	83	89	60	114	147	99	163	220	148
8	0	37	83	50	58	164	93	83	273	154	123	412	234
2	2	39	56	39	59	108	75	83	176	119	121	261	179
5	5	NR	NR	37	77	102	69	107	168	114	151	252	171
8	8	NR	NR	33	90	95	64	122	171	107	175	243	163
10	0	37	87	53	57	174	99	82	293	165	120	444	254
2	2	39	61	41	59	117	80	82	193	128	119	287	194
5	5	52	56	39	76	111	76	105	185	122	148	277	186
10	10	NR	NR	34	97	100	68	132	171	112	188	261	171
15	0	36	93	57	56	190	111	80	325	186	116	499	283
2	2	38	69	47	57	136	93	80	225	149	115	337	224
5	5	51	63	44	75	128	86	102	216	140	144	326	217
10	10	NR	NR	39	95	116	79	128	201	131	182	308	203
15	15	NR	NR	NR	NR	NR	72	158	186	124	220	290	192
20	0	35	96	60	54	200	118	78	346	201	114	537	306
2	2	37	74	50	56	148	99	78	248	165	113	375	248
5	5	50	68	47	73	140	94	100	239	158	141	363	239
10	10	NR	NR	41	93	129	86	125	223	146	177	344	224
15	15	NR	NR	NR	NR	NR	80	155	208	136	216	325	210
20	20	NR	NR	NR	NR	NR	NR	186	192	126	254	306	196
30	0	34	99	63	53	211	127	76	372	219	110	584	334
2	2	37	80	56	55	164	111	76	281	183	109	429	279
5	5	49	74	52	72	157	106	98	271	173	136	417	271
10	10	NR	NR	NR	91	144	98	122	255	168	171	397	257
15	15	NR	NR	NR	115	131	NR	151	239	157	208	377	242
20	20	NR	NR	NR	NR	NR	NR	181	223	NR	246	357	228
30	30	NR	NR	NR	NR	NR	NR	NR	NR	NR	NR	NR	NR
50	0	33	99	66	51	213	133	73	394	230	105	629	361
2	2	36	84	61	53	181	121	73	318	205	104	495	312
5	5	48	80	NR	70	174	117	94	308	198	131	482	305
10	10	NR	NR	NR	89	160	NR	118	292	186	162	461	292
15	15	NR	NR	NR	112	148	NR	145	275	174	199	441	280
20	20	NR	NR	NR	NR	NR	NR	176	257	NR	236	420	267
30	30	NR	NR	NR	NR	NR	NR	NR	NR	NR	315	376	NR

If the appliance cannot be moved closer to the vertical vent, then Type B vent could be used as the connector material. In this case, Table 7 shows that for a 30-Ft vent with 10 feet of lateral, the acceptable range of capacities for a 4 inch diameter vent attached to a fan-assisted appliance is a between 37,000 Btu/hr and 150,000 Btu/hr.

EXAMPLE 2: COMMON VENTING

In this case, a 35,000 Btu/hr input draft-hood -equipped water heater with a 2 foot connector rise is to be a common vented with a 100,000 Btu/hr fan-assisted furnace with a 3-Ft connector rise. The common vent consists of a 30-Ft rise Type B vent. What are the recommended vent diameters for each connector and the common vent?

SOLUTION - (TABLE 10A)

Water Heater Vent Connector Diameter. Let us assume the installation would like to use a single-wall metal vent connector. Using Table 10A Vent Connector Capacity, read down the Total Vent Height "H: column to 30 feet and read across the 2-Ft Connector Rise "R" row to the first Btu/hr rating in the "NAT Max" column that is equal to or greater than the water heater input rating. The table shows that a 3 inch vent connector is adequate. Furthermore, since the water heater is equipped with a draft hood, there are no minimum input rating restrictions.

Furnace Vent Connector Diameter. Again, let us assume the installer would like to use a single-wall metal vent connector. Using Table 10A, Vent Connector Capacity, read down the Total Vent Height "H" column to 30 feet and across the 3-Ft Connector Rise "R" row. Since the furnace has a fan-assisted combustion system, find the first "FAN Max" column with a Btu/hr rating greater than the furnace input rating. The 4 inch vent connector has a maximum input rating of 119,000 Btu/hr and a minimum input rating of 85,000 Btu/hr. The 100,000 Btu/hr furnace in this example falls within this range, so a 4 inch connector is adequate. If the furnace would have had an input rating of 80,000 Btu/hr, then a Type B vent connector (see Table 10A) would have to be used in order to meet the minimum capacity limit.

Common Vent Diameter. The total input to the common vent is 135,000 Btu/hr. Using Table 10B, Common Vent Capacity, read down the Total Vent Height "H" column to 30 feet and across this row to find the smallest vent diameter in the "FAN+NAT" column that has a Btu/hr rating equal to or greater than 135,000 Btu/hr. The 4 inch common vent has a capacity 132,000 Btu/hr and the 5 inch common vent has a capacity of 202,000 Btu/hr. Therefore, the 5 inch common should be used in this example.

Summary. In this example, the installer may use a 3 inch diameter, single-wall metal vent connector for the water heater and a 4 inch diameter, single-wall vent connector for the furnace. The common vent should be a 5 inch diameter Type B vent.

TABLE 9A
Capacity of Type B Double-Wall Vents with Type B Double-wall Connectors Serving Two or more Category I Appliances

Vent Height H (ft)	Connector Rise R (ft)	Vent Connector Diameter - D (inches)											
		3"			4"			5"			6"		
		Appliance Input Rating in Thousands of Btu Per Hour											
		FAN		NAT	FAN		NAT	FAN		NAT	FAN		NAT
Min	Max	Max	Min	Max	Max	Min	Max	Max	Min	Max	Max		
6	1	22	37	26	35	66	46	46	106	72	58	164	104
	2	23	41	31	37	75	55	48	121	86	60	183	124
	3	24	44	35	38	81	62	49	132	96	62	199	139
8	1	22	40	27	35	72	48	49	114	79	64	176	109
	2	23	44	32	36	80	57	51	128	90	66	195	129
	3	24	47	36	37	87	64	53	139	101	67	210	145
10	1	22	43	28	34	78	50	49	123	78	65	189	113
	2	23	47	33	36	86	59	51	136	93	67	206	134
	3	24	50	37	37	92	67	52	146	104	69	220	150
15	1	21	50	30	33	89	53	47	142	83	64	220	120
	2	22	53	35	35	96	63	49	153	99	66	235	142
	3	24	55	40	36	102	71	51	163	111	68	248	160
20	1	21	54	31	33	99	56	46	157	87	62	246	125
	2	22	57	37	34	105	66	48	167	104	64	259	149
	3	23	60	42	35	110	74	50	176	116	66	271	168
30	1	20	62	33	31	113	59	45	181	93	60	288	134
	2	21	64	39	33	118	70	47	190	110	62	299	158
	3	22	66	44	34	123	79	48	198	124	64	309	178
50	1	19	71	36	30	133	64	43	216	101	57	349	145
	2	21	73	43	32	137	76	45	223	119	59	358	172
	3	22	75	48	33	141	86	46	229	134	61	366	194
100	1	18	82	37	28	158	66	40	262	104	53	442	150
	2	19	83	44	30	161	79	42	267	123	55	447	178
	3	20	84	50	31	163	89	44	272	138	57	452	200

TABLE 9B

Common Vent Capacity

Vent Height H (ft)	Common Vent Diameter - D																				
	4"			5"			6"			7"			8"			9"			10"		
	Combined Appliance Input Rating in Thousands of Btu Per Hour																				
	FAN		NAT	FAN		NAT	FAN		NAT	FAN		NAT	FAN		NAT	FAN		NAT	FAN		NAT
+FAN	+NAT	+NAT	+FAN	+NAT	+NAT	+FAN	+NAT	+NAT	+FAN	+NAT	+NAT	+FAN	+NAT	+NAT	+FAN	+NAT	+NAT	+FAN	+NAT	+NAT	
6	92	81	65	140	116	103	204	161	147	309	248	200	404	314	260	547	434	335	672	520	410
8	101	90	73	155	129	114	224	178	163	339	275	223	444	348	290	602	480	378	740	577	465
10	110	97	79	169	141	124	243	194	178	367	299	242	477	377	315	649	522	405	800	627	495
15	125	112	91	195	164	144	283	228	206	427	352	280	556	444	365	753	612	465	924	733	565
20	136	123	102	215	183	160	314	255	229	475	394	310	621	499	405	842	688	523	1035	826	640
30	152	138	118	244	210	185	361	297	266	547	459	360	720	585	470	979	808	605	1209	975	740
50	167	153	134	279	244	214	421	353	310	641	547	423	854	706	550	1164	977	705	1451	1188	860
100	185	163	NR	311	277	NR	489	421	NR	751	653	479	1025	873	625	1408	1215	800	1784	1502	975

TABLE 10A

Capacity of Type B Double-Wall Vent with Single-Wall Connectors Serving Two or more Category I Appliances

Vent Height H (ft)	Connector Rise R (ft)	Vent Connector Diameter - D (inches)																							
		3"			4"			5"			6"			7"			8"			9"			10"		
		Appliance Input Rating in Thousands of Btu Per Hour																							
		FAN		NAT	FAN		NAT	FAN		NAT	FAN		NAT	FAN		NAT	FAN		NAT	FAN		NAT	FAN		NAT
Min	Max	Max	Min	Max	Max	Min	Max	Max	Min	Max	Max	Min	Max	Max	Min	Max	Max	Min	Max	Max	Min	Max	Max		
6	1	NR	NR	26	NR	NR	46	NR	NR	71	NR	NR	102	207	223	140	262	293	183	325	373	234	447	463	286
	2	NR	NR	31	NR	NR	55	NR	NR	85	168	182	123	215	251	167	271	331	219	334	422	281	458	524	344
	3	NR	NR	34	NR	NR	62	121	131	95	174	198	138	222	273	188	279	361	247	344	462	316	458	574	385
15	1	NR	NR	29	79	87	52	116	138	81	177	214	116	238	291	158	312	380	208	397	482	266	536	596	324
	2	NR	NR	34	83	94	62	121	150	97	185	230	138	246	314	189	321	411	248	407	522	317	568	646	387
	3	NR	NR	39	87	100	70	127	160	109	193	243	157	255	333	215	331	438	281	418	557	360	579	690	437
30	1	47	60	31	77	110	57	113	175	89	169	278	129	226	380	175	296	497	230	378	630	294	528	779	358
	2	50	62	37	81	115	67	117	185	106	177	290	152	236	397	208	307	521	274	389	662	349	541	819	425
	3	54	64	42	85	119	76	122	193	120	185	300	172	244	412	235	316	542	309	400	690	394	555	855	482
50	1	46	69	33	75	128	60	109	207	96	162	336	137	217	460	188	284	604	245	364	768	314	507	951	384
	2	49	71	40	79	132	72	114	215	113	170	345	164	226	473	223	294	623	293	376	793	375	520	983	458
	3	53	72	45	83	136	82	119	221	128	178	353	186	235	486	252	304	640	331	387	816	424	535	1013	518

TABLE 10B

Common Vent Capacity

Vent Height H (ft)	Common Vent Diameter - D																				
	4"			5"			6"			7"			8"			9"			10"		
	Combined Appliance Input Rating in Thousands of Btu Per Hour																				
	FAN +FAN	FAN +NAT	NAT +NAT	FAN +FAN	FAN +NAT	NAT +NAT	FAN +FAN	FAN +NAT	NAT +NAT	FAN +FAN	FAN +NAT	NAT +NAT	FAN +FAN	FAN +NAT	NAT +NAT	FAN +FAN	FAN +NAT	NAT +NAT	FAN +FAN	FAN +NAT	NAT +NAT
6	89	78	64	136	113	100	200	158	144	304	244	196	398	310	257	541	429	332	665	515	407
8	98	87	71	151	126	112	218	173	159	331	269	218	436	342	285	592	473	373	730	569	460
10	106	94	76	163	137	120	237	189	174	357	292	236	467	369	309	638	512	398	787	617	487
15	121	108	88	189	159	140	275	221	200	416	343	274	544	434	357	738	599	456	905	718	553
20	131	118	98	208	177	155	305	247	223	463	383	302	606	487	395	824	673	512	1013	808	626
30	145	132	113	236	202	179	250	286	257	533	446	349	703	570	459	958	790	593	1183	952	723
50	159	145	128	268	233	204	406	337	296	622	529	410	833	686	535	1139	954	689	1418	1157	838

TABLE 11

Capacity of Masonry Chimney with Type B Double-Wall Vent Connectors Serving A Single Category I Appliance

Connector Diameter (D in inches) - To be used with Chimney areas within size limits at bottom

Height H (ft)	Lateral L (ft)	3"		4"		5"		6"	
		FAN Min	NAT Max	FAN Min	NAT Max	FAN Min	NAT Max	FAN Min	NAT Max
6	2	NR	28	NR	52	NR	86	NR	130
	5	NR	25*	NR	49	NR	82	NR	117
10	2	NR	31	NR	61	NR	103	NR	162
	5	NR	28*	NR	57	NR	96	NR	148
	10	NR	25*	NR	50*	NR	87	NR	139
15	2	NR	35*	NR	67	NR	114	NR	179
	5	NR	33*	NR	62	NR	107	NR	164
	10	NR	28*	NR	55*	NR	97	NR	153
	15	NR	NR	NR	48*	NR	89*	NR	141
	20	NR	NR	NR	NR	NR	NR	NR	NR
20	2	NR	38*	NR	74	NR	124	NR	201
	5	NR	36*	NR	68*	NR	116	NR	184
	10	NR	NR	NR	60*	NR	107	NR	172
	15	NR	NR	NR	NR	NR	97	NR	158
	20	NR	NR	NR	NR	NR	83*	NR	148*
30	2	NR	41*	NR	82*	NR	137	NR	216
	5	NR	NR	NR	76*	NR	128*	NR	198
	10	NR	NR	NR	67*	NR	115*	NR	184*
	15	NR	NR	NR	NR	NR	107*	NR	171*
	20	NR	NR	NR	NR	NR	91*	NR	159*
	30	NR	NR	NR	NR	NR	NR	NR	NR
50	2	NR	NR	NR	92*	NR	161*	NR	251*
	5	NR	NR	NR	NR	NR	151*	NR	230*
	10	NR	NR	NR	NR	NR	138*	NR	215*
	15	NR	NR	NR	NR	NR	128*	NR	199*
	20	NR	NR	NR	NR	NR	NR	NR	185*
	30	NR	NR	NR	NR	NR	NR	NR	NR
Minimum Internal Area of Chimney - Square Inches		12		19		28		38	
Maximum Internal Area of Chimney - Square Inches		49		88		137		198	

* Possibility of continuous condensation

TABLE 12

Capacity of Masonry Chimney with Single-Wall Vent Connectors Serving A Single Category I Appliance

Connector Diameter (D in inches) - To be used with Chimney areas within size limits at bottom

Height H (ft)	Lateral L (ft)	3"		4"		5"		6"	
		FAN Min	NAT Max	FAN Min	NAT Max	FAN Min	NAT Max	FAN Min	NAT Max
6	2	NR	28	NR	52	NR	86	NR	130
	5	NR	25*	NR	4	NR	81	NR	116
10	2	NR	31	NR	61	NR	102	NR	161
	5	NR	28*	NR	56	NR	95	NR	147
	10	NR	24*	NR	49*	NR	86	NR	137
15	2	NR	35*	NR	67	NR	113	NR	178
	5	NR	32*	NR	61	NR	106	NR	163
	10	NR	27*	NR	54*	NR	96	NR	151
	15	NR	NR	NR	46*	NR	87*	NR	138
	20	NR	NR	NR	NR	NR	NR	NR	NR
20	2	NR	38*	NR	73	NR	123	NR	200
	5	NR	35*	NR	67*	NR	115	NR	183
	10	NR	NR	NR	59*	NR	105	NR	170
	15	NR	NR	NR	NR	NR	95	NR	156
	20	NR	NR	NR	NR	NR	80*	NR	144*
30	2	NR	41*	NR	81*	NR	136	NR	215
	5	NR	NR	NR	75*	NR	127*	NR	196
	10	NR	NR	NR	66*	NR	113*	NR	182*
	15	NR	NR	NR	NR	NR	105*	NR	168*
	20	NR	NR	NR	NR	NR	88*	NR	155*
	30	NR	NR	NR	NR	NR	NR	NR	NR
50	2	NR	NR	NR	91*	NR	160*	NR	250*
	5	NR	NR	NR	NR	NR	149*	NR	228*
	10	NR	NR	NR	NR	NR	136*	NR	212*
	15	NR	NR	NR	NR	NR	124*	NR	195*
	20	NR	NR	NR	NR	NR	NR	NR	180*
	30	NR	NR	NR	NR	NR	NR	NR	NR
Minimum Internal Area of Chimney - Square Inches		12		19		28		38	
Maximum Internal Area of Chimney - Square Inches		49		88		137		198	

* Possibility of continuous condensation

EXAMPLE 3

In this case, a 35,000 Btu/hr input 4 inch diameter outlet draft hood-equipped water heater with 2 feet of connector rise and 4 feet of horizontal length is to common vented with a 100,000 Btu/hr fan-assisted furnace with a 4 inch diameter flue collar, 3 feet of connector rise and 6 feet of horizontal length. The common vent is an 8 X 12 tile lined chimney that is 30 feet tall. What are the recommended vent diameters for each connector? Is this an acceptable installation?

SOLUTION

Table 14 is used to size common venting installations involving single wall connectors into masonry chimneys.

Water Heater Vent Connector Diameter. Using Table 14, Vent Connector Capacity, read down the Total Vent Height "H" column to 30 feet and read across the 2 ft. Connector Rise "R" row to the first Btu/hr rating in the "NAT MAX" column that is equal to or greater than the water heater input rating. The Table shows that a 3 inch vent connector has a maximum input of only 31,000 Btu/hr while a 4 inch vent connector has a maximum input of 57,000 Btu/hr. A 4 inch vent connector must therefore be used.

Furnace Vent Connector Diameter. Using Table 14 Vent connector Capacity, read down the Total Vent Height "H" column to 30 feet and across the 3 ft. Connector Rise "R" row. Since the furnace has a fan-assisted combustion system, find the first "FAN MAX" column with a Btu/hr rating greater than the furnace input rating. The 4 inch vent connector has a maximum input rating of 127,000 Btu/hr and a minimum input rating of 95,000 Btu/hr. The 100,000 Btu/hr furnace in this example within this range, so a 4 inch vent connector is adequate.

Masonry Chimney. From Table 15, the equivalent area for a Nominal Liner size of 8 inches X 12 inches is 63.6 square inches. Using Table 14 Common Vent Capacity, read down the "Fan + Nat" column under the Minimum Internal Area of Chimney value of 63 to the row for 30 ft. height, to find a capacity value of 739,000 Btu/hr. The 135,000 Btu/hr combined input rating of the furnace and water heater, is less than the Table value, so this is an acceptable installation.

INSTALLER'S GUIDE

Capacity of Masonry Chimney with Type B Double-Wall Connectors Serving two or more Category I Appliances

TABLE 13A Vent Connector Capacity

Vent Height H (ft)	Connector Rise R (ft)	Vent Connector Diameter - D (inches)																							
		3"		4"		5"		6"		7"		8"		9"		10"									
		Appliance Input Rating in Thousands of Btu Per Hour																							
		FAN		NAT	FAN		NAT	FAN		NAT	FAN		NAT	FAN		NAT	FAN		NAT	FAN		NAT	FAN		NAT
Min	Max	Max	Min	Max	Max	Min	Max	Max	Min	Max	Max	Min	Max	Max	Min	Max	Max	Min	Max	Max	Min	Max	Max		
6	1	24	NR	21	39	62	40	52	106	67	65	194	101	87	274	141	104	370	201	124	479	253	145	599	319
	2	26	43	28	41	79	52	53	133	85	67	230	124	89	324	173	107	436	232	127	562	330	148	694	378
	3	27	49	34	42	92	61	55	155	97	69	262	143	91	369	203	109	491	270	129	633	349	151	795	439
15	1	24	48	23	38	93	44	54	154	74	72	277	114	100	384	174	125	511	229	153	658	297	184	824	375
	2	25	55	31	39	105	55	56	174	89	74	299	134	103	419	192	128	558	263	156	718	339	187	900	432
	3	26	59	35	41	115	64	57	189	102	76	319	153	105	448	215	131	597	292	159	760	382	190	960	486
30	1	24	54	25	37	111	48	52	192	82	69	357	127	96	504	187	119	680	255	145	883	337	175	1115	432
	2	25	60	32	38	122	58	54	208	95	72	376	145	99	531	209	122	715	287	149	928	378	179	1171	484
	3	26	64	36	40	131	66	56	221	107	74	392	163	101	554	233	125	746	317	152	968	418	182	1220	535
50	1	23	52	26	36	116	49	51	209	82	67	405	133	92	582	198	115	798	271	140	1049	362	168	1334	462
	2	24	59	31	37	127	58	53	225	96	70	421	152	95	604	222	118	827	304	143	1085	400	172	1379	510
	3	26	64	37	39	135	66	55	237	108	72	435	170	98	624	247	121	854	334	147	1118	439	176	1421	558

TABLE 13B Common Vent Capacity

Vent Height H (ft)	Minimum Internal Area of Chimney, Square Inches																							
	12		19		28		38		50		63		78		113									
	Combined Appliance Input Rating in Thousands of Btu Per Hour																							
	FAN	FAN	NAT	FAN	FAN	NAT	FAN	FAN	NAT	FAN	FAN	NAT	FAN	FAN	NAT	FAN	FAN	NAT	FAN	FAN	NAT	FAN	FAN	NAT
+FAN	+NAT	+NAT	+FAN	+NAT	+NAT	+FAN	+NAT	+NAT	+FAN	+NAT	+NAT	+FAN	+NAT	+NAT	+FAN	+NAT	+NAT	+FAN	+NAT	+NAT	+FAN	+NAT	+NAT	
6	NR	74	25	NR	119	46	NR	178	71	NR	257	103	NR	351	143	NR	458	188	NR	582	246	NR	853	NR
8	NR	80	28	NR	130	53	NR	193	82	NR	279	119	NR	384	163	NR	501	218	NR	636	278	NR	937	408
10	NR	84	31	NR	138	56	NR	207	90	NR	299	131	NR	163	177	NR	538	236	NR	686	302	NR	1010	454
15	NR	90	36	NR	152	67	NR	233	106	NR	334	152	NR	177	212	NR	611	283	NR	781	365	NR	1156	546
20	NR	92	41	NR	159	75	NR	250	122	NR	368	172	NR	212	243	NR	668	325	NR	858	419	NR	1286	648
30	NR	NR	NR	NR	NR	NR	NR	270	137	NR	404	198	NR	243	278	NR	747	381	NR	969	496	NR	1473	749
50	NR	NR	NR	NR	NR	NR	NR	NR	NR	NR	NR	NR	NR	278	328	NR	831	461	NR	1089	606	NR	1692	922

Capacity of Masonry Chimney with Single-Wall Connectors Serving two or more Category I Appliances

TABLE 14A Vent Connector Capacity

Vent Height H (ft)	Connector Rise R (ft)	Vent Connector Diameter - D (inches)																							
		3"		4"		5"		6"		7"		8"		9"		10"									
		Appliance Input Rating in Thousands of Btu Per Hour																							
		FAN		NAT	FAN		NAT	FAN		NAT	FAN		NAT	FAN		NAT	FAN		NAT	FAN		NAT	FAN		NAT
Min	Max	Max	Min	Max	Max	Min	Max	Max	Min	Max	Max	Min	Max	Max	Min	Max	Max	Min	Max	Max	Min	Max	Max		
6	1	NR	NR	21	NR	NR	39	NR	NR	66	179	191	100	231	271	140	292	366	200	362	474	252	499	594	283
	2	NR	NR	28	NR	NR	52	NR	NR	84	186	227	123	239	321	172	301	432	231	373	557	299	509	696	331
	3	NR	NR	34	NR	NR	61	134	153	97	193	258	142	247	365	202	309	491	269	381	634	348	519	793	375
15	1	NR	NR	23	NR	NR	43	129	151	73	199	271	112	268	376	171	349	502	225	445	646	291	623	808	360
	2	NR	NR	30	92	103	54	135	170	88	207	295	132	277	411	189	359	548	256	456	706	334	634	884	402
	3	NR	NR	34	96	112	63	141	185	101	215	315	151	286	439	213	368	586	289	466	755	378	646	945	437
30	1	NR	NR	24	86	108	47	126	187	80	193	347	124	259	492	183	338	665	250	430	864	330	600	1089	455
	2	NR	NR	31	91	119	57	132	203	93	201	366	142	269	518	205	348	699	282	442	908	372	613	1145	490
	3	NR	NR	35	95	127	65	138	216	105	209	381	160	277	540	229	358	729	312	452	946	412	626	1193	521
50	1	NR	NR	25	85	113	48	124	204	80	188	392	130	252	567	194	328	778	265	417	1022	355	582	1302	537
	2	NR	NR	31	89	123	57	130	218	94	196	408	149	262	588	218	339	806	298	429	1058	393	596	1346	567
	3	NR	NR	35	94	131	65	136	231	106	205	422	167	271	607	243	349	831	328	440	1090	431	610	1386	595

TABLE 14B Common Vent Capacity

Vent Height H (ft)	Minimum Internal Area of Chimney, Square Inches																							
	12		19		28		38		50		63		78		113									
	Combined Appliance Input Rating in Thousands of Btu Per Hour																							
	FAN	FAN	NAT	FAN	FAN	NAT	FAN	FAN	NAT	FAN	FAN	NAT	FAN	FAN	NAT	FAN	FAN	NAT	FAN	FAN	NAT	FAN	FAN	NAT
+FAN	+NAT	+NAT	+FAN	+NAT	+NAT	+FAN	+NAT	+NAT	+FAN	+NAT	+NAT	+FAN	+NAT	+NAT	+FAN	+NAT	+NAT	+FAN	+NAT	+NAT	+FAN	+NAT	+NAT	
6	NR	73	25	NR	118	45	NR	176	71	NR	255	102	NR	348	142	NR	455	187	NR	579	245	NR	846	NR
8	NR	79	25	NR	128	52	NR	190	81	NR	276	118	NR	380	162	NR	497	217	NR	633	277	NR	928	405
10	NR	83	31	NR	136	56	NR	205	89	NR	295	129	NR	405	175	NR	532	234	NR	680	300	NR	1000	450
15	NR	88	16	NR	149	66	NR	230	105	NR	335	150	NR	460	210	NR	602	280	NR	772	360	NR	1139	540
20	NR	90	40	NR	157	74	NR	247	120	NR	362	170	NR	503	240	NR	661	321	NR	849	415	NR	1264	640
30	NR	NR	NR	NR	NR	NR	NR	266	135	NR	398	195	NR	558	275	NR	739	377	NR	957	490	NR	1447	710
50	NR	NR	NR	NR	NR	NR	NR	NR	NR	NR	NR	NR	NR	612	325	NR	821	456	NR	1076	600	NR	1672	910

TABLE 15

**MASONRY CHIMNEY LINEAR DIMENSIONS
WITH CIRCULAR EQUIVALENTS**

NOMINAL LINEAR SIZE INCHES	INSIDE DIMENSION IN LINEAR INCHES	INSIDE DIAMETER OR EQUIVALENT DIAMETER INCHES	EQUIVALENT AREA SQUARE INCHES
4 X 8	2-1/2 X 6-1/2	4	12.2
		5	19.6
		6	28.3
		7	38.3
8 X 8	6-3/4 X 6-3/4	7.4	42.7
		8	50.3
8 X 12	6-1/2 X 10-1/2	9	63.6
		10	78.5
12 X 12	9-3/4 X 9-3/4	10.4	83.3
		11	95
12 X 16	9-1/2 X 13-1/2	11.8	107.5
		12	113
		14	153.9
16 X 16	13-1/4 X 13-1/4	14.5	162.9
		15	176.7
16 X 20	13 X 17	16.2	206.1
		18	254.4
20 X 20	16-3/4 X 16-3/4	18.2	260.2
		20	314.1
		22	380.1
20 X 24	16-1/2 X 20-1/2	20.1	314.2
		22	380.1
24 X 24	20-1/4 X 20-1/4	22.1	380.1
		24	452.3
24 X 28	20-1/2 X 24-1/4	24.1	456.2
28 X 28	24-1/2 X 24-1/4	26.4	543.3
		27	572.5
30 X 30	25-1/2 X 25-1/2	27.9	607
		30	706.8
30 X 36	25-1/2 X 31-1/2	30.9	749.9
		33	855.3
36 X 36	31-1/2 X 31-1/2	34.4	929.4
		36	1017.9

When liner sizes differ dimensionally from those shown in this table, equivalent diameters may be determined from published tables for square and rectangular ducts of equivalent carrying capacity or by other engineering methods.

ELECTRICAL CONNECTIONS

Make wiring connections to the unit as indicated on enclosed wiring diagram. As with all gas appliances using electrical power, this furnace shall be connected into a permanently live electric circuit. It is recommended that it be provided with a separate "circuit protection device" electric circuit. The furnace must be electrically grounded in accordance with local codes or in the absence of local codes with the National Electrical Code, ANSI/NFPA "latest edition", if an external electrical source is utilized.

Refer to the SERVICE FACTS literature for unit wiring diagrams.

GAS PIPING

This unit is shipped standard for left side installation of gas piping. A piping knock-out is also provided in the right side for an alternate piping arrangement. The installation of piping shall be in accordance with piping codes and the regulations of the local gas company. Pipe joint compound must be resistant to the chemical reaction with liquified petroleum gases.

Refer to piping Table 16, for delivery sizes. Connect gas supply to the unit, using a ground joint union and a manual shut-off valve as shown in Figure 21. National codes require a condensation drip leg to be installed ahead of the controls as shown in Figure 21.

The furnace and its individual shut-off valve must be disconnected from the gas supply piping system during any pressure testing of that system at test pressures in excess of 1/2 psig.

The furnace must be isolated from the gas supply piping by closing its individual manual shut-off valve during any pressure testing of the gas supply piping system at test pressures equal to or less than 1/2 psig.

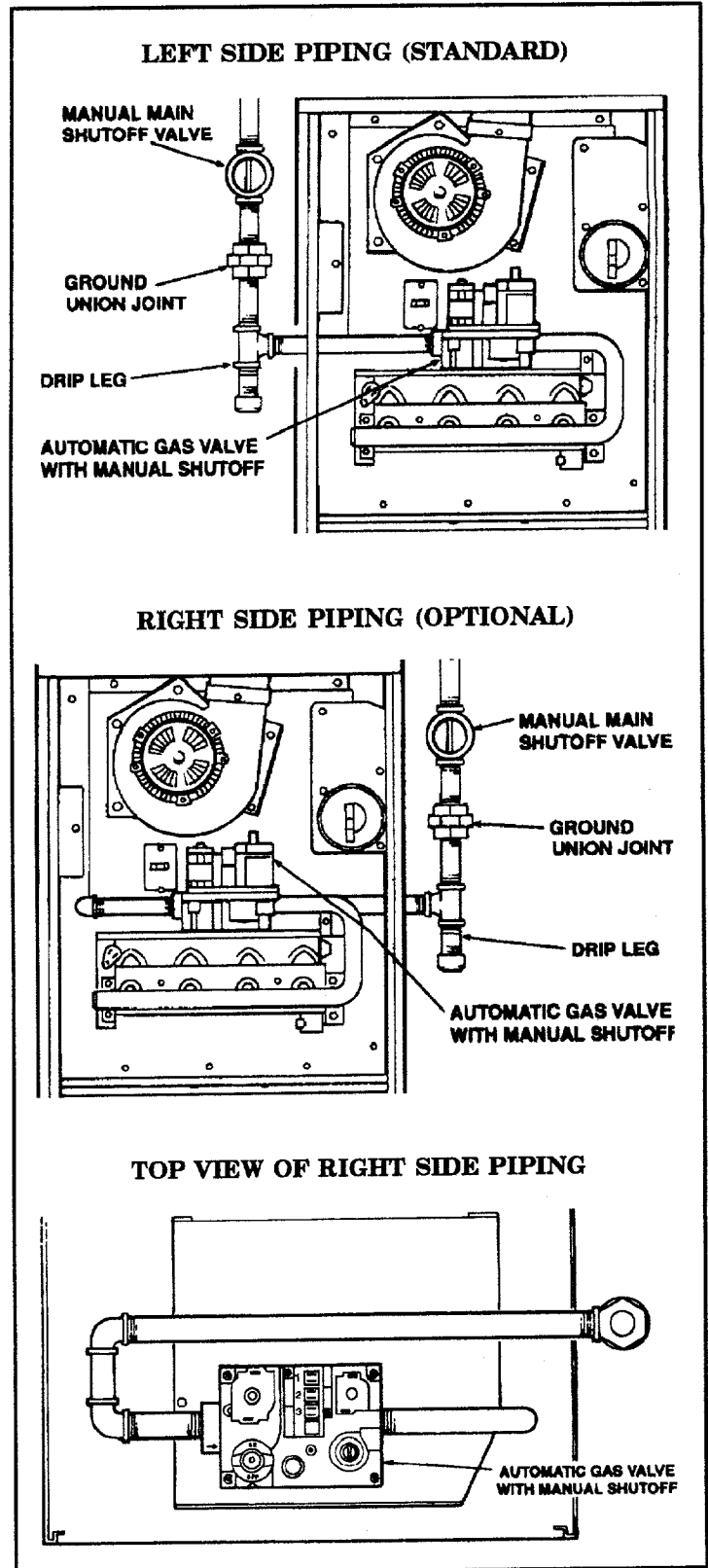

FIGURE 21

NOTE: Maximum pressure to the gas valve for natural gas is 10.5" W.C. Minimum pressure is 5.0" W.C. Maximum pressure to the gas valve for propane is 13.0" W.C. Minimum pressure is 11.0" W.C.

All gas fittings must be checked for leaks using a soapy solution before lighting the furnace. DO NOT CHECK WITH AN OPEN FLAME!

INSTALLER'S GUIDE

START UP AND ADJUSTMENT

PRELIMINARY INSPECTIONS

With gas and electrical power "OFF"

1. Duct connections are properly sealed
2. Filters are in place
3. Venting is properly assembled
4. Blower door is in place

Turn knob on main gas valve within the unit to the "OFF" position. Turn the external gas valve to "ON". Purge the air from the gas lines. After purging, Check all gas connections for leaks with a soapy solution -- **DO NOT CHECK WITH AN OPEN FLAME.** Allow 5 minutes for any gas that might have escaped to dissipate. LP Gas being heavier than air may require forced ventilation. Turn the knob on the gas valve in the unit to the "ON" position.

The following warning complies with State of California law, Proposition 65.

WARNING: Hazardous Gasses!
Exposure to fuel substances or by-products of incomplete fuel combustion is believed by the state of California to cause cancer, birth defects, or other reproductive harm.

COMBUSTION AND INPUT CHECK

1. Make sure all gas appliances are off except the furnace.
2. Clock the gas meter with the furnace operating (determine the dial rating of the meter) for one revolution.
3. Match the "Sec" column in the gas flow (in cfh) Table 19 with the time clocked.
4. Read the "Flow" column opposite the number of seconds clocked.
5. Use the following factors if necessary:
 - For 1 Cu. Ft. Dial Gas Flow CFH =
Chart Flow Reading /2
 - For 1/2 Cu Ft. Dial Gas Flow CFH =
Chart Flow Reading /4
 - For 5 Cu. Ft. Dial Gas Flow CFH =
10X Chart Flow Reading /4
6. Multiply the final figure by the heating value of the gas obtained from the utility company and compare to the nameplate rating. This must not exceed the nameplate rating.
7. Changes can be made by adjusting the manifold pressure or changing orifices (orifice change may not always be required).

- a. Attach a manifold pressure gauge.
- b. Remove the slot screw on top of the gas valve for manifold pressure adjustment.
- c. Turn the adjustment screw in to increase the gas flow rate, and out to decrease the gas flow rate.
- d. The final manifold pressure setting shall be no less than 3.0" W.C. and no more than 3.5" W.C. with an input of no more than nameplate rating and no less than 93 % of the nameplate rating, unless the unit is derated for high altitude.

For LP gases, the final manifold pressure shall be no less than 10.0" W.C. and no more than 10.5" W.C. with an input of no more than the nameplate rating and no less than 93% of the nameplate rating, unless the unit is derated for altitude.

Table 17 lists the main burner orifices shipped with the furnace, If a change of orifices is required to correct the manifold pressure rating refer to Table 18.

Table 16 (Natural Gas Only)

TABLE OF CUBIC FEET PER HOUR OF GAS FOR VARIOUS PIPE SIZES AND LENGTHS							
PIPE SIZE	LENGTH OF PIPE IN FEET						
	10	20	30	40	50	60	70
1/2	132	92	73	63	56	50	46
3/4	278	190	152	130	115	105	96
1	520	350	285	245	215	195	180
1-1/4	1050	730	590	520	440	400	370

This Table is based on pressure drop of 0.3 inch W.C. and 0.6 SP. GR. gas.

Table 17
ORIFICES SHIPPED WITH FURNACE

INPUT RATING BTUH	NO. OF BURNERS	MAIN BURNER ORIFICE DRILL SIZE	
		NAT. GAS	PROPANE
40,000	2	44	55
60,000	3	44	55
80,000	4	44	55
100,000	5	44	55
120,000	6	44	55
140,000	7	44	55

Table 18
PART NUMBERS FOR REPLACEMENT ORIFICES

Drill Size	Part Number	Drill Size	Part Number
31	ORF0384	45	ORF0694
32	ORF0499	46	ORF0909
33	ORF0387	47	ORF0910
34	ORF0386	49	ORF0503
35	ORF0488	50	ORF0493
36	ORF0500	51	ORF0494
37	ORF0385	52	ORF0495
38	ORF0497	53	ORF0491
39	ORF0517	54	ORF0492
40	ORF0408	55	ORF0693
41	ORF0502	56	ORF0907
44	ORF0502	57	ORF0908

HIGH ALTITUDE DERATE

It may be necessary to change burner orifices also, due to the altitude of the installation. Ratings of these furnaces are based on sea level operation and need not be changed at elevations up to 2,000 ft. If the installation is 2,000 ft. or above, ratings should be reduced at the rate of 4 % for each 1,000 ft. above sea level. Table 20 will provide a guide for this selection.

Use High Altitude Kit BAYHALT220 for installations above 4,000 ft. (a pressure switch change is required).

SEQUENCE OF OPERATION

Thermostat call for heat

R and W thermostat contacts close signaling the control module to run its self-check routine. After the control module has verified that the pressure switch contacts are open and the limit switch(es) contacts are closed, the draft blower will be energized.

TABLE 19

GAS FLOW IN CUBIC FEET PER HOUR

2 CUBIC FOOT DIAL							
SEC.	FLOW	SEC.	FLOW	SEC.	FLOW	SEC.	FLOW
8	900	29	248	50	144	82	88
9	800	30	240	51	141	84	86
10	720	31	232	52	138	86	84
11	655	32	225	53	136	88	82
12	600	33	218	54	133	90	80
13	555	34	212	55	131	92	78
14	514	35	206	56	129	94	76
15	480	36	200	57	126	96	75
16	450	37	195	58	124	98	73
17	424	38	189	59	122	100	72
18	400	39	185	60	120	104	69
19	379	40	180	62	116	108	67
20	360	41	176	64	112	112	64
21	343	42	172	66	109	116	62
22	327	43	167	68	106	120	60
23	313	45	164	70	103	124	58
24	300	46	160	72	100	128	56
25	288	47	157	74	97	132	54
26	277	48	153	76	95	136	53
27	267	49	150	78	92	140	51
28	257	50	147	80	90	144	50

As the induced draft blower comes up to speed, the pressure switch contacts will close and the ignitor warm up period will begin. The ignitor will heat for approx. 17 seconds, then the gas valve is energized in to permit gas flow to the burners. The flame sensor confirms that ignition has been achieved within the 6 second ignition trial period.

After the flame sensor confirms that ignition has been achieved, the delay to fan ON period begins timing and after approx. 45 seconds the I.D. blower motor will be energized and will continue to run during the heating cycle.

When the thermostat is satisfied, R and W thermostat contacts open, the gas valve will close, the flames will extinguish, and the induced draft blower will be de-energized. The I.D. blower motor will continue to run for the fan off period (Field selectable at 90, 120, 150 or 210 seconds), then will be de-energized by the control module.

LIGHTING INSTRUCTIONS

WARNING: DO NOT attempt to manually light the burner.

Lighting instructions appear on each unit. Each installation must be checked out at the time of initial start up to insure proper operation of all components. Check out should include putting the unit through one complete cycle as outlined below.

Turn on the main electrical supply and set the thermostat above the indicated temperature. The ignitor will automatically heat, then the gas valve is energized to permit the flow of gas to the burners. After ignition and flame is established, the flame control module monitors the flame and supplies power to the gas valve until the thermostat is satisfied.

TABLE 20

Correction Table for Burner Orifice Drill Sizes for Furnaces Installed at Altitudes 2000 Feet and More Above Sea Level

Orifice Twist Drill Size If Installed At Sea Level	ALTITUDE ABOVE SEA LEVEL						
	2000	3000	4000	5000	6000	7000	8000
31	32	32	32	33	34	35	36
32	33	34	35	35	36	36	37
33	35	7/64	36	36	37	38	38
34	35	36	36	37	37	38	39
35	36	36	37	37	38	39	40
36	37	38	38	39	40	41	3/32
37	38	39	39	40	41	3/32	42
38	39	40	41	41	3/32	42	43
39	40	41	3/32	42	42	43	43
40	3/32	3/32	42	42	43	43	44
41	42	42	42	43	43	44	44
42	42	43	43	43	44	44	45
43	44	44	44	45	45	46	47
44	45	45	45	5/64	47	47	48
45	46	5/64	47	47	48	48	49
50	51	51	51	51	52	52	1/16
51	51	52	52	1/16	52	53	53
52	1/16	53	53	53	53	53	54
53	54	54	54	54	54	54	55
54	54	55	55	55	55	3/64	56
55	55	3/64	3/64	3/64	3/64	3/64	56

To shut off.

For complete shut-down: Turn the gas cock knob on the main gas valve to the "OFF" position. Disconnect the electrical supply to the unit.

CAUTION: If this is done during the cold weather months, provisions must be taken to prevent freeze-up of all water pipes and water receptacles.

Whenever your house is to be vacant, arrange to have someone inspect your house for proper temperature. This is very important during freezing weather. If for any reason your furnace should fail to operate damage could result, such as frozen water pipes.

LIMIT SWITCH CHECK OUT

The limit switch is a safety device designed to close the gas valve should the furnace become overheated. Since proper operation of this switch is important to the safety of the unit, it **must be checked out on initial start up by the installer.**

To check for proper operation of the limit switches, set the thermostat to a temperature higher than the indicated temperature to bring on the gas valve. Restrict the airflow by blocking the return air or by disconnecting the blower. When the furnace reaches the maximum outlet temperature as shown on the rating plate, the burners must shut off. If they do not shut off after a reasonable time and over-heating is evident, a faulty limit switch is probable and the limit switch must be replaced. After checking the operation of the limit control, be sure to remove the paper or cardboard from the return air inlet, or reconnect the blower.

NOTE TO INSTALLER

Review the warnings below with the owner. Review contents of OWNER'S INFORMATION MANUAL with the owner.

INSTALLER'S GUIDE

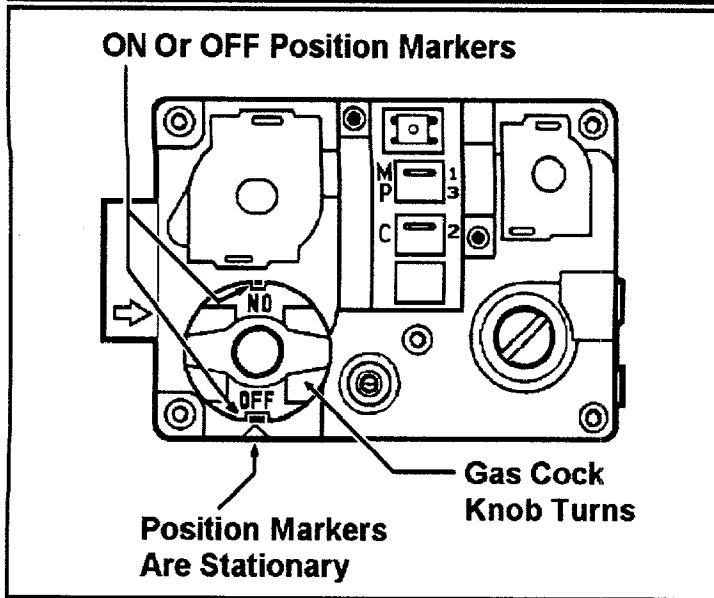

AIRFLOW ADJUSTMENT

Check inlet and outlet air temperatures to make sure they are within the ranges specified on the furnace rating nameplate. If the airflow needs to be increased or decreased, see the wiring diagram for information on changing the speed of the blower motor.

WARNING: Disconnect power to the unit before removing the blower door.

This unit is equipped with a blower door switch which cuts power to the blower and gas valve causing shutdown when the door is removed. Operation with the door removed or ajar can permit the escape of dangerous fumes. All panels must be securely closed at all times for safe operation of the furnace.

INDOOR BLOWER TIMING

Heating: The control module controls the indoor blower. The blower start is fixed at 45 seconds after ignition. The FAN-OFF period is field selectable by dip switches at 90, 120, 150, or 210 seconds. The factory setting is 150 seconds, (See wiring diagram).

Cooling: The fan delay off period is factory set at 0 seconds. The option for 80 second delay off is field selectable, (See wiring diagram).

NOTE: Direct drive motors have bearings which are permanently lubricated and under normal use, lubrication is not recommended.

ROOM AIR THERMOSTAT HEAT ANTICIPATOR ADJUSTMENT

Set the thermostat heat anticipator according to the current flow measured, or the settings found in the notes on the furnace wiring diagram, (found in the SERVICE FACTS or inside the furnace casing).

INSTRUCTIONS TO THE OWNERS

In the event that electrical, fuel, or mechanical failures occur, the owner should immediately turn the gas supply off at the manual gas valve, located in the burner compartment. Also turn off electrical power to the furnace and contact the service agency designated by your dealer.

Periodic inspection and cleaning of the screen in the vent terminal is required for proper, safe operation of the furnace.

OPERATING INFORMATION

FLAME ROLL-OUT DEVICE

All models are equipped with a fusible link on the burner cover.

In case of flame roll-out, the link will open (melt) and cause the circuit to open which shuts off all flow of gas.

ABNORMAL CONDITIONS

1. EXCESSIVE COMBUSTION VENT PRESSURE OR FLUE BLOCKAGE

If pressure against induced draft blower outlet becomes excessive, the pressure switch will open and shut off the gas valve until acceptable combustion pressure is again available.

2. LOSS OF FLAME

If loss of flame occurs during a heating cycle, when flame is not present at the sensor, the flame control module will close the gas valve. The flame control module will then recycle the ignition sequence, then if ignition is not achieved, it will shut off the gas valve and lock out the system.

3. POWER FAILURE

If there is a power failure during a heating cycle, the system will restart the ignition sequence automatically when power is restored, if the thermostat still calls for heat.

4. GAS SUPPLY FAILURE

If loss of flame occurs during a heating cycle, the system integrated control module will re-cycle the ignition sequence. If ignition is not achieved, the integrated control module will shut off the gas valve and lock out the system.

5. INDUCED DRAFT BLOWER FAILURE

If pressure is not sensed by the pressure switch, the contacts will remain open and not allow the gas valve to open, therefore the unit will not start. If failure occurs during a running cycle, the pressure switch contacts will open and the gas valve will close to shut the unit down.

6. RESET AFTER LOCKOUT

When the integrated control module has shut the system down and gone into lockout, the system must be manually reset before the unit will restart. To reset, turn the system power off, then on, then off and then on again within 30 seconds. This may be done at the unit's power source or at the thermostat. *The system will not reset unless the procedure off-on-off-on is completed within 30 seconds.*

The following warning complies with State of California law, Proposition 65.

WARNING: This product contains fiberglass wool insulation! Fiberglass dust and ceramic fibers are believed by the state of California to cause cancer through inhalation. Glasswool fibers may also cause respiratory, skin, or eye irritation.

PRECAUTIONARY MEASURES

- Avoid breathing fiberglass dust.
- Use a NIOSH approved dust/mist respirator.
- Avoid contact with the skin or eyes. Wear long-sleeved, loose fitting clothing, gloves, and eye protection.
- Wash clothes separately from other clothing; rinse washer thoroughly.
- Operations such as sawing, blowing, tear-out, and spraying may generate fiber concentrations requiring additional respiratory protection. Use the appropriate NIOSH approved respirator in these situations.

FIRST AID MEASURES

- Eye Contact** - Flush eyes with water to remove dust. If symptoms persist, seek medical attention.
- Skin Contact** - Wash affected areas gently with soap and warm water after handling.

FIELD WIRING DIAGRAM FOR HEATING ONLY

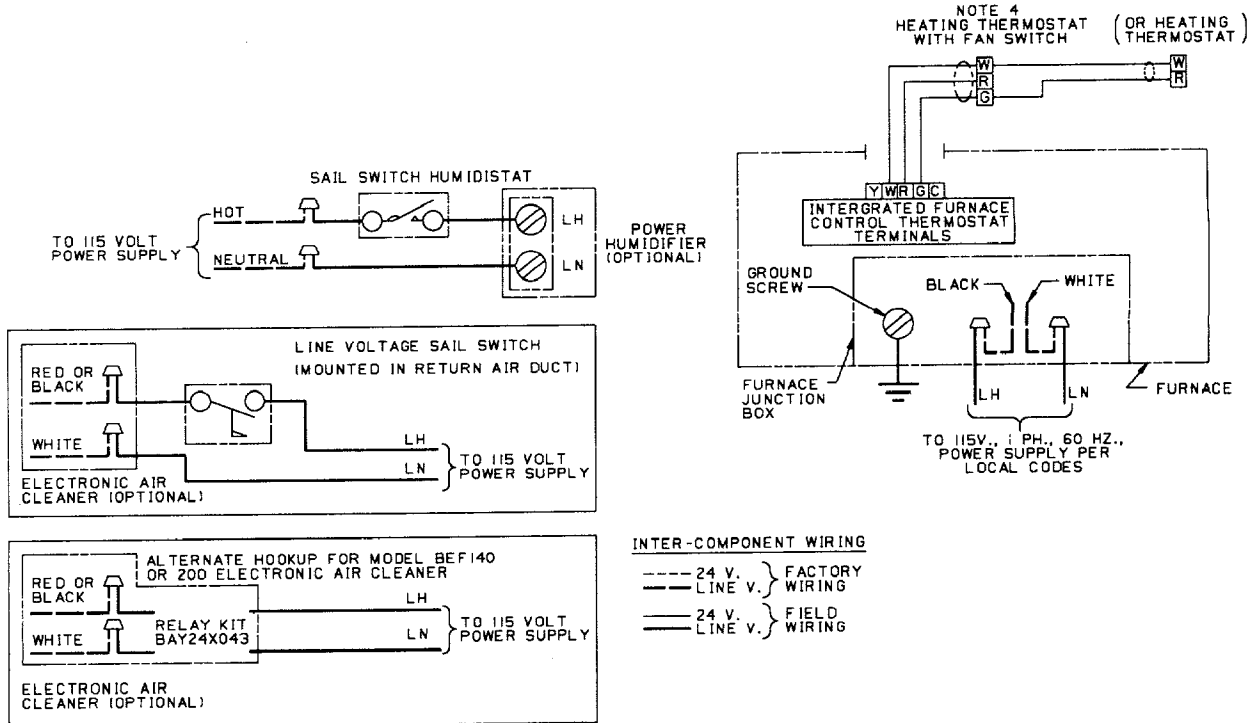

NOTES:

1. BE SURE POWER SUPPLY AGREES WITH EQUIPMENT NAMEPLATE(S).
2. LOW VOLTAGE (24 V.) WIRING TO BE NO. 18 A.W.G. MIN.
3. GROUNDING OF EQUIPMENT MUST COMPLY WITH LOCAL CODES.
4. SET THERMOSTAT HEAT ANTICIPATOR PER UNIT WIRING DIAGRAM.

From Dwg. 21B330199 Rev. 1

FIELD WIRING DIAGRAM FOR HEATING/COOLING (OUTDOOR SECTION WITHOUT TRANSFORMER)

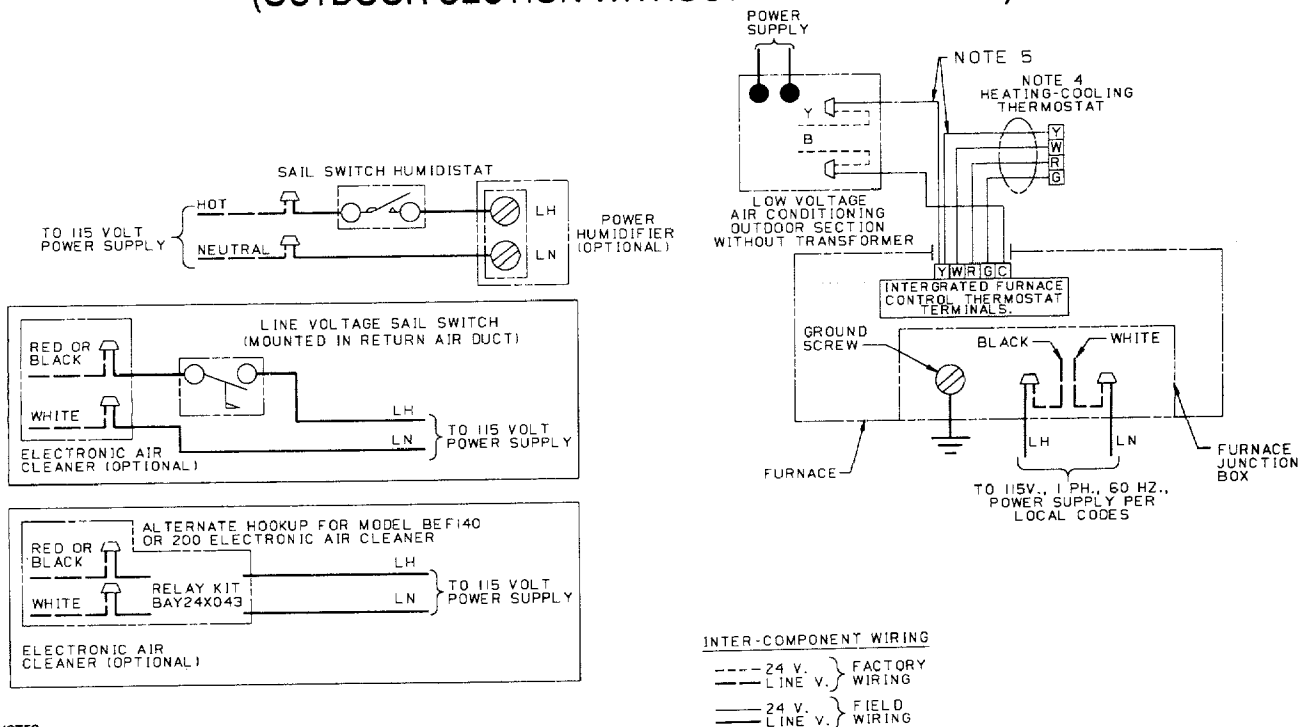

NOTES:

1. BE SURE POWER SUPPLY AGREES WITH EQUIPMENT NAMEPLATE(S).
2. LOW VOLTAGE (24 V.) WIRING TO BE NO. 18 A.W.G. MIN.
3. GROUNDING OF EQUIPMENT MUST COMPLY WITH LOCAL CODES.
4. SET THERMOSTAT HEAT ANTICIPATOR PER UNIT WIRING DIAGRAM.
5. THE "Y" TERMINAL FROM THE THERMOSTAT MUST BE WIRED TO THE "Y" TERMINAL OF THE FURNACE CONTROL FOR PROPER BLOWER OPERATION DURING COOLING.

From Dwg. 21B330200 Rev. 1

INSTALLER'S GUIDE

*DD-C OUTLINE DRAWING (ALL DIMENSIONS ARE IN INCHES)

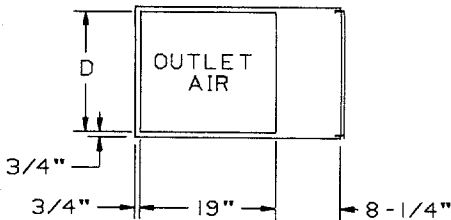
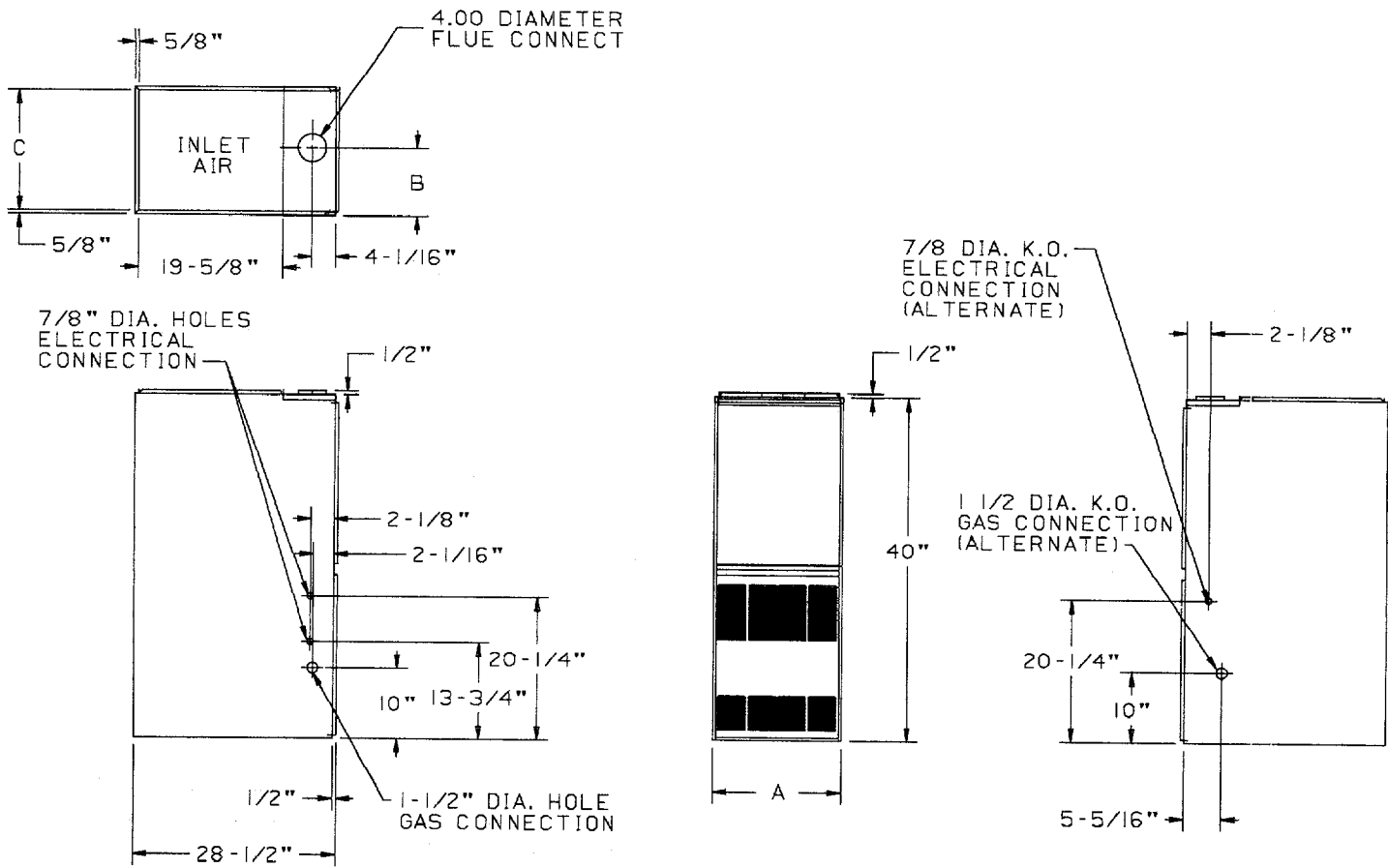

MODEL	A	B	C	D
*DD040C924B	14-1/4"	9-5/8"	13-1/4"	13"
*DD060C936B	14-1/4"	9-5/8"	13-1/4"	13"
*DD080C936B	17-1/2"	9-5/8"	16-1/4"	16"
*DD080C945B	17-1/2"	9-5/8"	16-1/4"	16"
*DD100C945B	17-1/2"	9-5/8"	16-1/4"	16"
*DD100C948B	21"	13-1/16"	19-3/4"	19-1/2"
*DD100C960B	21"	13-1/16"	19-3/4"	19-1/2"
*DD120C960B	24-1/2"	15-5/16"	23-1/4"	23"
*DD140C960B	24-1/2"	15-5/16"	23-1/4"	23"

* - The First Letter May Be "A" or "T"

MINIMUM CLEARANCE TO COMBUSTIBLE MATERIALS
DOWNFLOW CLOSET SIDES 3" IN. W/SINGLE WALL VENT - 0 IN. W/TYPE B-I VENT FLUE 6" IN. W/SINGLE WALL VENT - 1 IN. W/TYPE B-I VENT FRONT 6" IN. BACK 0 IN. TOP 1 IN. * RIGHT SIDE ONLY 14.5 IN. CABINETS. 0 IN. TO LEFT SIDE, 0 IN. FOR REMAINING CABINET SIZES (17.5", 21", 24.5"). - FOR INSTALLATION ON COMBUSTIBLE FLOORING ONLY WHEN INSTALLED ON SPECIAL BASE. - PART # BAYBASE 208
HORIZONTAL CLOSET (FLUE DISCHARGE LEFT) TOP 3" IN. W/SINGLE WALL VENT - 2 IN. W/TYPE B-I VENT FLUE 6" IN. W/SINGLE WALL VENT - 1 IN. W/TYPE B-I VENT FRONT 6" IN. BACK 3" IN. SIDES 1" IN. * TOP ONLY WITH 14.5 IN. WIDTH CABINETS. 2 IN. FOR CABINET WIDTHS 17.5", 21", 24.5".
HORIZONTAL CLOSET (FLUE DISCHARGE RIGHT) TOP 2" IN. W/SINGLE WALL VENT FLUE 6" IN. W/SINGLE WALL VENT - 1 IN. W/TYPE B-I VENT FRONT 6" IN. BACK 3" IN. SIDES 1" IN. - FOR INSTALLATION ON COMBUSTIBLE FLOORING ONLY WHEN B-I VENT CONNECTOR IS USED.
HORIZONTAL ALCOVE (FLUE DISCHARGE LEFT) TOP 3" IN. W/SINGLE WALL VENT - 1 IN. W/TYPE B-I VENT FLUE 6" IN. W/SINGLE WALL VENT - 1 IN. W/TYPE B-I VENT FRONT 18" IN. BACK 0 IN. SIDES 0 IN. * TOP ONLY WITH 14.5 IN. WIDTH CABINETS. 1" IN. FOR CABINET WIDTHS 17.5", 21", 24.5".
HORIZONTAL ALCOVE (FLUE DISCHARGE RIGHT) TOP 1" IN. W/SINGLE WALL VENT FLUE 6" IN. W/SINGLE WALL VENT - 1 IN. W/TYPE B-I VENT FRONT 18" IN. BACK 0 IN. SIDES 0 IN.

From Dwg 21C340155 Rev. 5

IMPORTANT NOTE: Additional service information, replacement parts listing, unit wiring diagrams and troubleshooting charts are included in the **Service Facts** literature provided with these instructions. The **Service Facts** pamphlet is customer property and is to remain with the unit when installed.

