



Service Facts

Split System Heat Pump 4TWX6024B1000A

⚠ CAUTION

UNIT CONTAINS R-410A REFRIGERANT!
R-410A OPERATING PRESSURE EXCEEDS THE LIMIT OF R-22. PROPER SERVICE EQUIPMENT IS REQUIRED. FAILURE TO USE PROPER SERVICE TOOLS MAY RESULT IN EQUIPMENT DAMAGE OR PERSONAL INJURY.

SERVICE
USE ONLY R-410A REFRIGERANT AND APPROVED POE COMPRESSOR OIL.

IMPORTANT — This document contains a wiring diagram, a parts list, and service information. This is customer property and is to remain with this unit. Please return to service information pack upon completion of work.

⚠ WARNING: HAZARDOUS VOLTAGE - DISCONNECT POWER and DISCHARGE CAPACITORS BEFORE SERVICING

PRODUCT SPECIFICATIONS

OUTDOOR UNIT ①②	4TWX6024B1000A
POWER CONNS. — V/PH/HZ ③	230/1/60
MIN. BRCH. CIR. AMPACITY	13
BR. CIR. } MAX. (AMPS)	20
PROT. RTG. } MIN. (AMPS)	20
COMPRESSOR	CLIMATUFF® - SCROLL
NO. USED - NO. SPEEDS	1 - 1
VOLTS/PH/HZ	230/1/60
R.L. AMPS ⑦ - L.R. AMPS	10.3 - 52
FACTORY INSTALLED	
START COMPONENTS ⑧	YES
INSULATION/SOUND BLANKET	YES
COMPRESSOR HEAT	YES
OUTDOOR FAN	PROPELLER
DIA. (IN.) - NO. USED	23 - 1
TYPE DRIVE - NO. SPEEDS	DIRECT - 1
CFM @ 0.0 IN. W.G. ④	2300
NO. MOTORS - HP	1 - 1/15
MOTOR SPEED R.P.M.	825
VOLTS/PH/HZ	200/230/1/60
F.L. AMPS	0.6
OUTDOOR COIL — TYPE	SPINE FIN™
ROWS - F.P.I.	1 - 24
FACE AREA (SQ. FT.)	21.20
TUBE SIZE (IN.)	5/16
REFRIGERANT CONTROL	EXPANSION VALVE
REFRIGERANT	
LBS. — R-410A (O.D. UNIT) ⑤	5 LBS. -12 OZ.
FACTORY SUPPLIED	YES
LINE SIZE - IN. O.D. GAS ⑥	5/8
LINE SIZE - IN. O.D. LIQ. ⑥	5/16
FCCV	
RESTRICTOR ORIFICE SIZE	N/A
DIMENSIONS	H X W X D
CRATED (IN.)	47.6 x 30.1 x 33
WEIGHT	
SHIPPING (LBS.)	261
NET (LBS.)	226

TUBING INFORMATION

Tubing Sizes		Tubing Length	Additional Refrigerant
Suction	Liquid		
5/8"	5/16"	20'	2 oz.
5/8"	5/16"	30'	6 oz.
5/8"	5/16"	40'	10 oz.
5/8"	5/16"	50'	13 oz.
5/8"	5/16"	60'	17 oz.

Tubing lengths in excess of eighty (80) feet see application software.

- ① Certified in accordance with the Air-Source Unitary Heat Pump Equipment certification program, which is based on A.R.I. standard 210/240.
- ② Rated in accordance with A.R.I. standard 270.
- ③ Calculated in accordance with Natl. Elec. Codes. Only use HACR circuit breakers or fuses.
- ④ Standard Air — Dry Coil — Outdoor
- ⑤ This value approximate. For more precise value see unit nameplate.
- ⑥ Max. linear length 80 ft.; Max. lift - Suction 25 ft.; Max lift - Liquid 25 ft. For greater length consult refrigerant piping software Pub. No. 32-3312-0* (* denotes latest revision).
- ⑦ This value shown for compressor RLA on the unit nameplate and on this specification sheet is used to compute minimum branch circuit ampacity and max. fuse size. The value shown is the branch circuit selection current.
- ⑧ No means no start components. Yes means quick start kit components. PTC means positive temperature coefficient starter.

E - SPLIT HEAT PUMP

⚠ CAUTION

HOT SURFACE!
DO NOT TOUCH TOP OF COMPRESSOR.
May cause minor to severe burning.

⚠ CAUTION

CONTAINS REFRIGERANT!
SYSTEM CONTAINS OIL AND REFRIGERANT UNDER HIGH PRESSURE. RECOVER REFRIGERANT TO RELIEVE PRESSURE BEFORE OPENING SYSTEM.
Failure to follow proper procedures can result in personal illness or injury or severe equipment damage.

⚠ WARNING

THIS INFORMATION IS INTENDED FOR USE BY INDIVIDUALS POSSESSING ADEQUATE BACKGROUNDS OF ELECTRICAL AND MECHANICAL EXPERIENCE. ANY ATTEMPT TO REPAIR A CENTRAL AIR CONDITIONING PRODUCT MAY RESULT IN PERSONAL INJURY AND OR PROPERTY DAMAGE. THE MANUFACTURER OR SELLER CANNOT BE RESPONSIBLE FOR THE INTERPRETATION OF THIS INFORMATION, NOR CAN IT ASSUME ANY LIABILITY IN CONNECTION WITH ITS USE.

⚠ CAUTION

RECONNECT ALL GROUNDING DEVICES. ALL PARTS OF THIS PRODUCT CAPABLE OF CONDUCTING ELECTRICAL CURRENT ARE GROUNDED. IF GROUNDING WIRES, SCREWS, STRAPS, CLIPS, NUTS OR WASHERS USED TO COMPLETE A PATH TO GROUND ARE REMOVED FOR SERVICE, THEY MUST BE RETURNED TO THEIR ORIGINAL POSITION AND PROPERLY FASTENED.

NOTICE: Trane has a policy of continuous product and product data improvement and it reserves the right to change design and specifications without notice.

SCHEMATIC DIAGRAM

4TWX6024B1000A

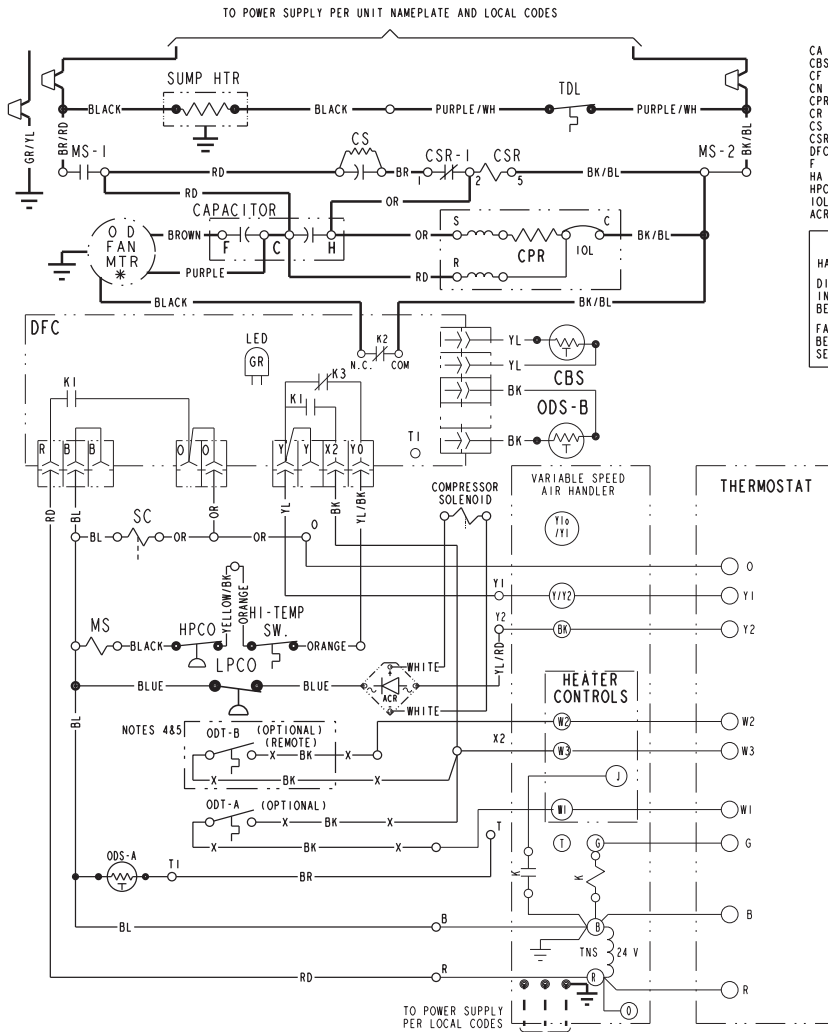

- | | | | |
|------|-----------------------------|------|----------------------------|
| CA | COOLING ANTICIPATOR | LPCO | LOW PRESSURE CUTOFF SW. |
| CBS | COIL BOTTOM SENSOR | MS | COMPRESSOR MOTOR CONTACTOR |
| CF | FAN CAPACITOR | ODA | OUTDOOR ANTICIPATOR |
| CN | WIRE CONNECTOR | OFT | OUTDOOR FAN THERMOSTAT |
| CPR | COMPRESSOR | ODS | OUTDOOR TEMPERATURE SENSOR |
| CR | RUN CAPACITOR | ODT | OUTDOOR THERMOSTAT |
| CS | STARTING CAPACITOR | RHS | RESISTANCE HEAT SWITCH |
| CSR | CAPACITOR SWITCHING RELAY | SC | SWITCHOVER VALVE SOLENOID |
| DFC | DEFROST CONTROL | SM | SYSTEM "ON-OFF" SWITCH |
| F | INDOOR FAN RELAY | TDL | DISCHARGE LINE THERMOSTAT |
| HA | HEATING ANTICIPATOR | TNS | TRANSFORMER |
| HPCO | HIGH PRESSURE CUTOFF SW. | THS | HEATING-COOLING THERMOSTAT |
| IOL | INTERNAL OVERLOAD PROTECTOR | TSH | HEATING THERMOSTAT |
| ACR | A/C RECTIFIER | | |

<p>WARNING</p> <p>HAZARDOUS VOLTAGE!</p> <p>DISCONNECT ALL ELECTRIC POWER INCLUDING REMOTE DISCONNECTS BEFORE SERVICING.</p> <p>FAILURE TO DISCONNECT POWER BEFORE SERVICING CAN CAUSE SEVERE PERSONAL INJURY OR DEATH!</p>	<p>CAUTION</p> <p>USE COPPER CONDUCTORS ONLY! UNIT TERMINALS ARE NOT DESIGNED TO ACCEPT OTHER TYPES OF CONDUCTORS.</p> <p>FAILURE TO DO SO MAY CAUSE DAMAGE TO THE EQUIPMENT!</p>
--	--

- NOTES:
- BE SURE POWER SUPPLY AGREES WITH EQUIPMENT NAMEPLATE.
 - POWER WIRING AND GROUNDING OF EQUIPMENT MUST COMPLY WITH LOCAL CODES.
 - LOW VOLTAGE WIRING TO BE NO. 18 AWG MINIMUM CONDUCTOR.
 - ODT-B MUST BE SET LOWER THAN ODT-A
 - IF ODT-B IS NOT USED, CONNECT A JUMPER WIRE FROM W3 TO W2. IF ODT-A IS NOT USED, CONNECT A JUMPER WIRE FROM W2 TO W1.
 - IF ELECTRIC HEATER DOES NOT HAVE A 3RD CONTACTOR (CH), CONNECT A JUMPER WIRE FROM W3 TO W2. IF ELECTRIC HEATER DOES NOT HAVE A 2ND CONTACTOR (BH), CONNECT A JUMPER WIRE FROM W2 TO W1.
 - X2 MUST BE CONNECTED TO VARIABLE SPEED AIR HANDLER TERMINAL W3, AS SHOWN, FOR PROPER INDOOR AIR FLOW DURING THE DEFROST CYCLE.
 - BE SURE THE JUMPER BETWEEN R AND BK IS CUT OR REMOVED.
 - WITH O AND Y/Y2 ENERGIZED, INDOOR FAN IS AT 80% AIRFLOW.
 - WITH O, Y/Y2 AND BK ENERGIZED, INDOOR FAN IS AT 100% AIRFLOW.

FOR CANADIAN INSTALLATIONS
POUR INSTALLATIONS CANADIENNES

CAUTION: NOT SUITABLE FOR USE ON SYSTEMS EXCEEDING 150V-TO-GROUND.
ATTENTION: NE CONVIENT PAS AUX INSTALLATIONS DE PLUS DE 150 V A LA TERRE.

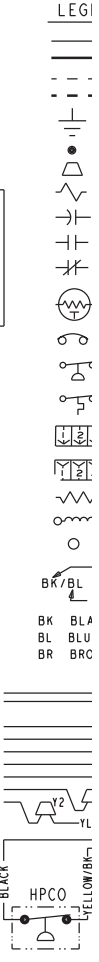

REFRIGERANT CIRCUIT

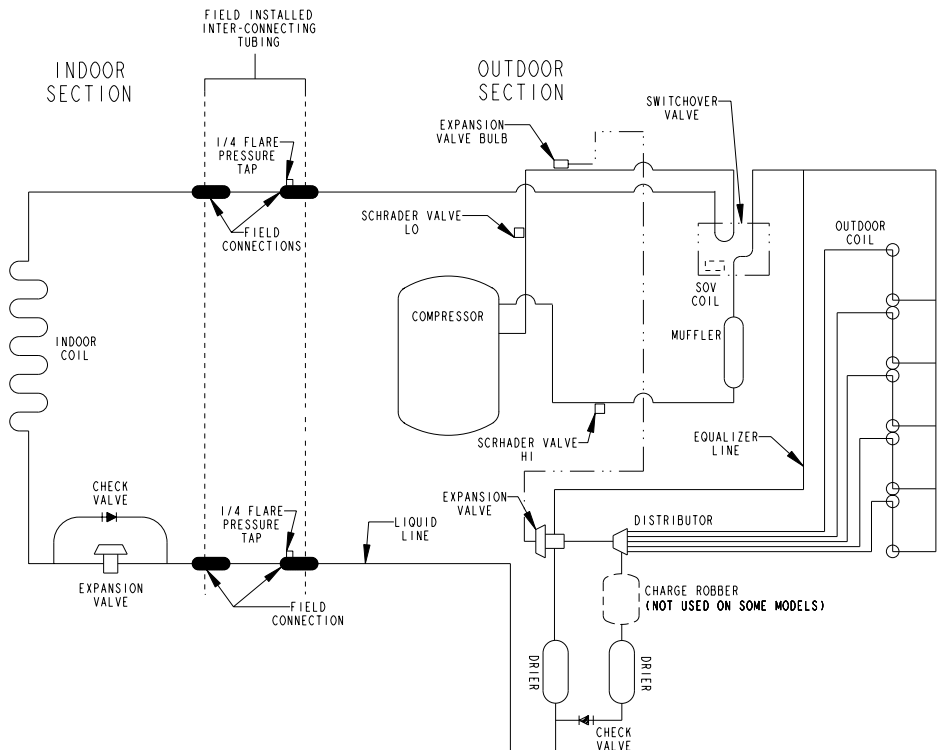

FOR FIRST S

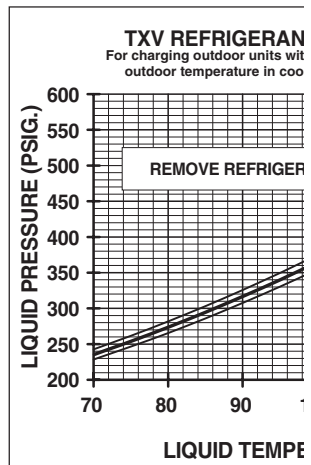

- Measure Liquid Line Temperature and Refrigerant Pressure at service valves.
- Determine total refrigerant pipe length and height (lift) if indoor section is above the condenser. Plot the intersection of the two points on the Curve Selection Chart to determine which curve to use.
- Plot the pressure and temperature on the TXV Charging Curve.
- If the lines cross above the curve remove refrigerant, if below curve add refrigerant.
- Whenever charge or added, the system should be operated for 20 minutes to allow the refrigerant to settle.
- When system is fully charged, refer to the performance chart for the specific charge and performance.

WIRING DIAGRAM

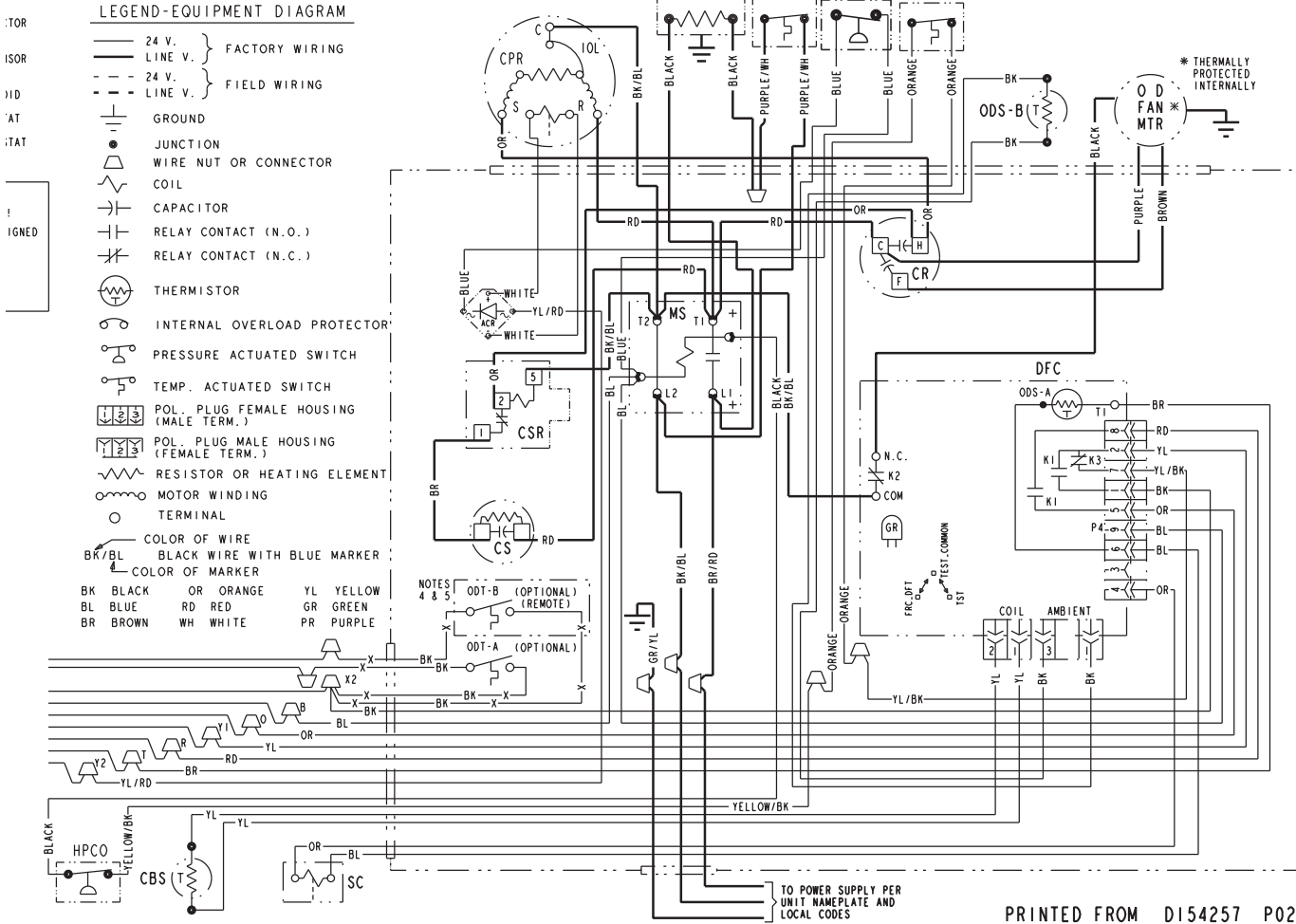

FIRST STAGE ONLY

REFRIGERANT CHARGING CURVE

For charging outdoor units with R-410A refrigerant at above 65°F outdoor temperature in cooling mode and with indoor TXV.

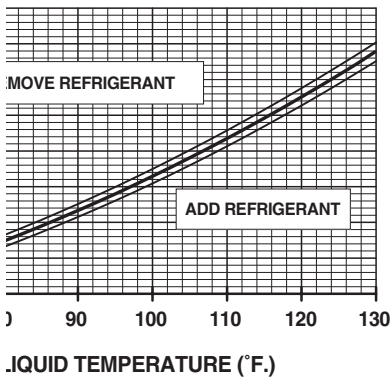

- Whenever charge is removed or added, the system must be operated for a minimum 20 minutes to stabilize before additional measurements can be made.
- When system is correctly charged refer to System Performance Curves to verify charge and performance.

CHARGING CURVE SELECTION CHART

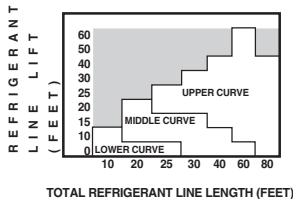

A150999P03 REV.0

FOR SECOND STAGE ONLY

TXV REFRIGERANT CHARGING CURVE

For charging outdoor units with R-410A refrigerant at above 65°F outdoor temperature in cooling mode and with indoor TXV.

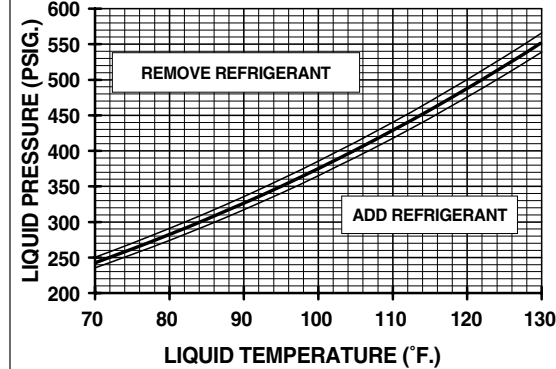

- Measure Liquid Line Temperature and Refrigerant Pressure at service valves.
- Determine total refrigerant pipe length and height (lift) if indoor section is above the condenser. Plot the intersection of the two points on the Curve Selection Chart to determine which curve to use.
- Plot the pressure and temperature on the TXV Charging Curve.
- If the lines cross above the curve remove refrigerant, if below curve add refrigerant.

- Whenever charge is removed or added, the system must be operated for a minimum 20 minutes to stabilize before additional measurements can be made.
- When system is correctly charged refer to System Performance Curves to verify charge and performance.

CHARGING CURVE SELECTION CHART

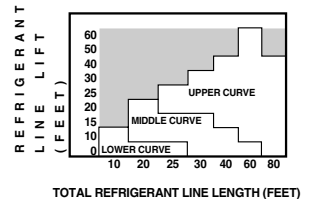

A150999P05 REV.0

