



**TRANE®**

**4TWX6048-SF-1C**

# Service Facts

## Split System Heat Pump 4TWX6048B1000B

### ⚠ CAUTION

**UNIT CONTAINS R-410A REFRIGERANT!**  
R-410A OPERATING PRESSURE EXCEEDS THE LIMIT OF R-22. PROPER SERVICE EQUIPMENT IS REQUIRED. FAILURE TO USE PROPER SERVICE TOOLS MAY RESULT IN EQUIPMENT DAMAGE OR PERSONAL INJURY.

### SERVICE

USE ONLY R-410A REFRIGERANT AND APPROVED POE COMPRESSOR OIL.

**IMPORTANT** — This document contains a wiring diagram, a parts list, and service information. This is customer property and is to remain with this unit. Please return to service information pack upon completion of work.

## ⚠ WARNING: HAZARDOUS VOLTAGE - DISCONNECT POWER and DISCHARGE CAPACITORS BEFORE SERVICING

### PRODUCT SPECIFICATIONS

<b>OUTDOOR UNIT</b> ①②	<b>4TWX6048B1000B</b>
<b>POWER CONNS.</b> — V/PH/HZ ③	230/1/60
MIN. BRCH. CIR. AMPACITY	28
BR. CIR. } MAX. (AMPS)	45
PROT. RTG. } MIN. (AMPS)	40
<b>COMPRESSOR</b>	CLIMATUFF® - SCROLL
NO. USED - NO. SPEEDS	1 - 1
VOLTS/PH/HZ	230/1/60
R.L. AMPS ⑦ - L.R. AMPS	21.2 - 96
<b>FACTORY INSTALLED</b>	
START COMPONENTS ⑧	NO
INSULATION/SOUND BLANKET	YES
COMPRESSOR HEAT	YES
<b>OUTDOOR FAN</b>	PROPELLER
DIA. (IN.) - NO. USED	27.6 - 1
TYPE DRIVE - NO. SPEEDS	DIRECT - 1
CFM @ 0.0 IN. W.G. ④	4675/4675
NO. MOTORS - HP	1 - 1/5
MOTOR SPEED R.P.M.	820
VOLTS/PH/HZ	200/230/1/60
F.L. AMPS	1.10
<b>OUTDOOR COIL</b> — TYPE	SPINE FIN™
ROWS - F.P.I.	1 - 24
FACE AREA (SQ. FT.)	27.81
TUBE SIZE (IN.)	5/16
REFRIGERANT CONTROL	EXPANSION VALVE
<b>REFRIGERANT</b>	
LBS. — R-410A (O.D. UNIT) ⑤	9 LBS. - 1 OZ.
FACTORY SUPPLIED	YES
LINE SIZE - IN. O.D. GAS ⑥	7/8
LINE SIZE - IN. O.D. LIQ. ⑥	3/8
<b>CHARGING SPECIFICATION</b>	
SUBCOOLING	9°F
<b>DIMENSIONS</b>	H X W X D
CRATED (IN.)	53.4 x 35.1 x 38.7
UNCRATED (IN.)	See Outline Drawing
<b>WEIGHT</b>	
SHIPPING (LBS.)	318
NET (LBS.)	270

### TUBING INFORMATION

Tubing Sizes		Tubing Length	Additional Refrigerant
Suction	Liquid		
7/8"	3/8"	20'	3 oz.
7/8"	3/8"	30'	9 oz.
7/8"	3/8"	40'	16 oz.
7/8"	3/8"	50'	22 oz.
7/8"	3/8"	60'	28 oz.

Tubing lengths in excess of sixty (60) feet see application software.

- ① Certified in accordance with the Air-Source Unitary Heat Pump Equipment certification program, which is based on ARI standard 210/240.
- ② Rated in accordance with ARI standard 270.
- ③ Calculated in accordance with Natl. Elec. Codes. Use only HACR circuit breakers or fuses.
- ④ Standard Air — Dry Coil — Outdoor
- ⑤ This value approximate. For more precise value see unit nameplate.
- ⑥ Max. linear length 60 ft.; Max. lift - Suction 60 ft.; Max lift - Liquid 60 ft. For greater length consult refrigerant piping software Pub. No. 32-3312-0\* (\* denotes latest revision).
- ⑦ This value shown for compressor RLA on the unit nameplate and on this specification sheet is used to compute minimum branch circuit ampacity and max. fuse size. The value shown is the branch circuit selection current.
- ⑧ No means no start components. Yes means quick start kit components. PTC means positive temperature coefficient starter.

### ⚠ CAUTION

**HOT SURFACE!**  
**DO NOT TOUCH TOP OF COMPRESSOR.**  
May cause minor to severe burning.

### ⚠ CAUTION

**CONTAINS REFRIGERANT!**  
**SYSTEM CONTAINS OIL AND REFRIGERANT UNDER HIGH PRESSURE. RECOVER REFRIGERANT TO RELIEVE PRESSURE BEFORE OPENING SYSTEM.**  
Failure to follow proper procedures can result in personal illness or injury or severe equipment damage.

### ⚠ CAUTION

RECONNECT ALL GROUNDING DEVICES.  
ALL PARTS OF THIS PRODUCT CAPABLE OF CONDUCTING ELECTRICAL CURRENT ARE GROUNDED. IF GROUNDING WIRES, SCREWS, STRAPS, CLIPS, NUTS OR WASHERS USED TO COMPLETE A PATH TO GROUND ARE REMOVED FOR SERVICE, THEY MUST BE RETURNED TO THEIR ORIGINAL POSITION AND PROPERLY FASTENED.

### ⚠ WARNING

THIS INFORMATION IS INTENDED FOR USE BY INDIVIDUALS POSSESSING ADEQUATE BACKGROUNDS OF ELECTRICAL AND MECHANICAL EXPERIENCE. ANY ATTEMPT TO REPAIR A CENTRAL AIR CONDITIONING PRODUCT MAY RESULT IN PERSONAL INJURY AND OR PROPERTY DAMAGE. THE MANUFACTURER OR SELLER CANNOT BE RESPONSIBLE FOR THE INTERPRETATION OF THIS INFORMATION, NOR CAN IT ASSUME ANY LIABILITY IN CONNECTION WITH ITS USE.

**NOTICE:** Trane has a policy of continuous product and product data improvement and it reserves the right to change design and specifications without notice.

### SCHEMATIC DIAGRAM

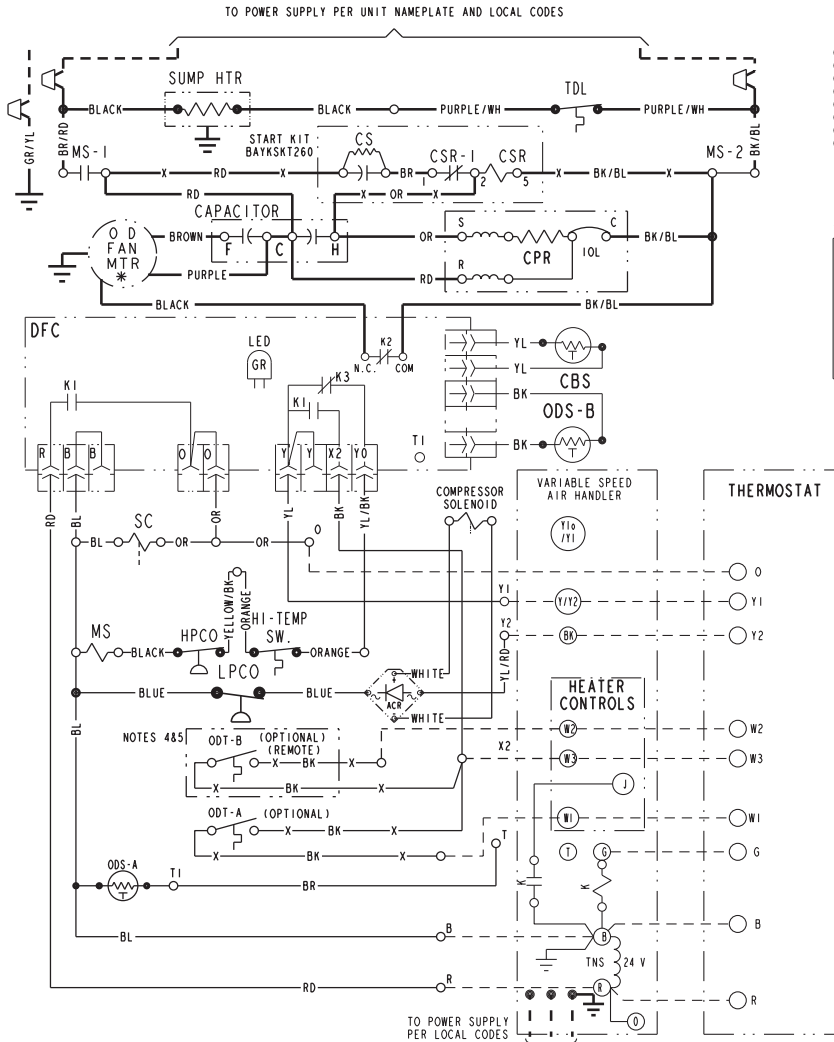

- |      |                             |      |                            |
|------|-----------------------------|------|----------------------------|
| CA   | COOLING ANTICIPATOR         | LPCO | LOW PRESSURE CUTOFF SW.    |
| CBS  | COIL BOTTOM SENSOR          | MS   | COMPRESSOR MOTOR CONTACTOR |
| CF   | FAN CAPACITOR               | ODA  | OUTDOOR ANTICIPATOR        |
| CW   | WIRE CONNECTOR              | ODT  | OUTDOOR FAN THERMOSTAT     |
| CPR  | COMPRESSOR                  | ODS  | OUTDOOR TEMPERATURE SENSOR |
| CR   | RUN CAPACITOR               | ODT  | OUTDOOR THERMOSTAT         |
| CS   | STARTING CAPACITOR          | RHS  | RESISTANCE HEAT SWITCH     |
| CSR  | CAPACITOR SWITCHING RELAY   | SC   | SWITCHOVER VALVE SOLENOID  |
| DFC  | DEFROST CONTROL             | SM   | SYSTEM "ON-OFF" SWITCH     |
| F    | INDOOR FAN RELAY            | TDL  | DISCHARGE LINE THERMOSTAT  |
| HA   | HEATING ANTICIPATOR         | TNS  | TRANSFORMER                |
| HPCO | HIGH PRESSURE CUTOFF SW.    | TS   | HEATING-COOLING THERMOSTAT |
| IOL  | INTERNAL OVERLOAD PROTECTOR | TSH  | HEATING THERMOSTAT         |
| ACR  | A/C RECTIFIER               |      |                            |

<p><b>⚠ WARNING</b> HAZARDOUS VOLTAGE! DISCONNECT ALL ELECTRIC POWER INCLUDING REMOTE DISCONNECTS BEFORE SERVICING. FAILURE TO DISCONNECT POWER BEFORE SERVICING CAN CAUSE SEVERE PERSONAL INJURY OR DEATH!</p>	<p><b>⚠ CAUTION</b> USE COPPER CONDUCTORS ONLY! UNIT TERMINALS ARE NOT DESIGNED TO ACCEPT OTHER TYPES OF CONDUCTORS. FAILURE TO DO SO MAY CAUSE DAMAGE TO THE EQUIPMENT!</p>
---	--

- NOTES:
- BE SURE POWER SUPPLY AGREES WITH EQUIPMENT NAMEPLATE.
  - POWER WIRING AND GROUNDING OF EQUIPMENT MUST COMPLY WITH LOCAL CODES.
  - LOW VOLTAGE WIRING TO BE NO. 18 AWG MINIMUM CONDUCTOR.
  - ODT-B MUST BE SET LOWER THAN ODT-A
  - IF ODT-B IS NOT USED, CONNECT A JUMPER WIRE FROM W3 TO W2. IF ODT-A IS NOT USED, CONNECT A JUMPER WIRE FROM W2 TO W1.
  - IF ELECTRIC HEATER DOES NOT HAVE A 3RD CONTACTOR (CH), CONNECT A JUMPER WIRE FROM W3 TO W2. IF ELECTRIC HEATER DOES NOT HAVE A 2ND CONTACTOR (BH), CONNECT A JUMPER WIRE FROM W2 TO W1.
  - X2 MUST BE CONNECTED TO VARIABLE SPEED AIR HANDLER TERMINAL W3, AS SHOWN, FOR PROPER INDOOR AIR FLOW DURING THE DEFROST CYCLE.
  - BE SURE THE JUMPER BETWEEN R AND BK IS CUT OR REMOVED.
  - WITH O AND Y/Y2 ENERGIZED, INDOOR FAN IS AT 80% AIRFLOW.
  - WITH O, Y/Y2 AND BK ENERGIZED, INDOOR FAN IS AT 100% AIRFLOW.

FOR CANADIAN INSTALLATIONS  
POUR INSTALLATIONS CANADIENNES  
**CAUTION: NOT SUITABLE FOR USE ON SYSTEMS EXCEEDING 150V-TO-GROUND.**  
**ATTENTION: NE CONVIENT PAS AUX INSTALLATIONS DE PLUS DE 150 V A LA TERRE.**

### SUBCOOLING CHARGING IN COOLING ABOVE 55°F OD AMBIENT

The Trane company has always recommended installing Trane approved matched indoor and outdoor systems.

All Trane split systems are ARI rated with only TXV indoor systems.

The benefits of installing approved indoor and outdoor split systems are maximum efficiency, optimum performance and the best overall system reliability.

The following charging methods are therefore prescribed for systems with indoor TXVs.

- Subcooling (in the cooling mode) is the only recommended method of charging above 55°F ambient temperatures.
- For best results – the indoor temperature should be kept between 70°F to 80°F. Add system heat if needed.
- At startup, or whenever charge is removed or added, the system must be operated for a minimum 20 minutes to stabilize before accurate measurements can be made.
- Measure Liquid Line Temperature and Refrigerant Pressure at service valves.
- Determine total refrigerant line length, and height (lift) if indoor section is above the condenser.

- Determine the Design Subcool Charging Temperature from the unit nameplate.
- Locate this value in the appropriate column of the Subcooling Charging Table. Locate your liquid line temperature in the left column of the table, and the intersecting liquid line pressure under your nameplate subcool value column. Add refrigerant to raise the pressure to match the table, or remove refrigerant to lower the pressure. Again, wait 20 minutes for the system conditions to stabilize before adjusting charge again.
- When system is correctly charged, you can refer to System Pressure Curves (on page 4) to verify typical performance.

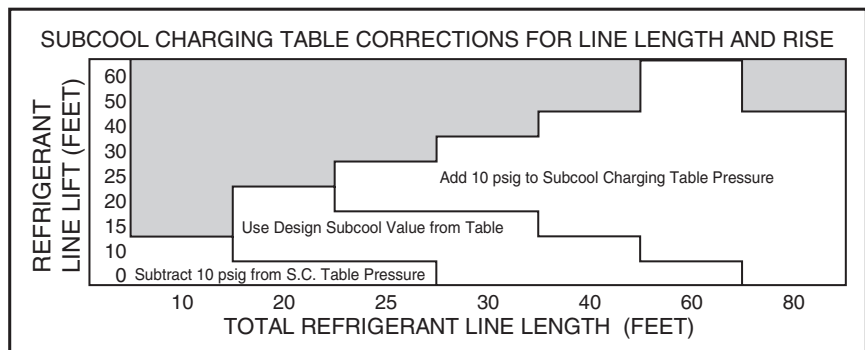

WIRING DIAGRAM

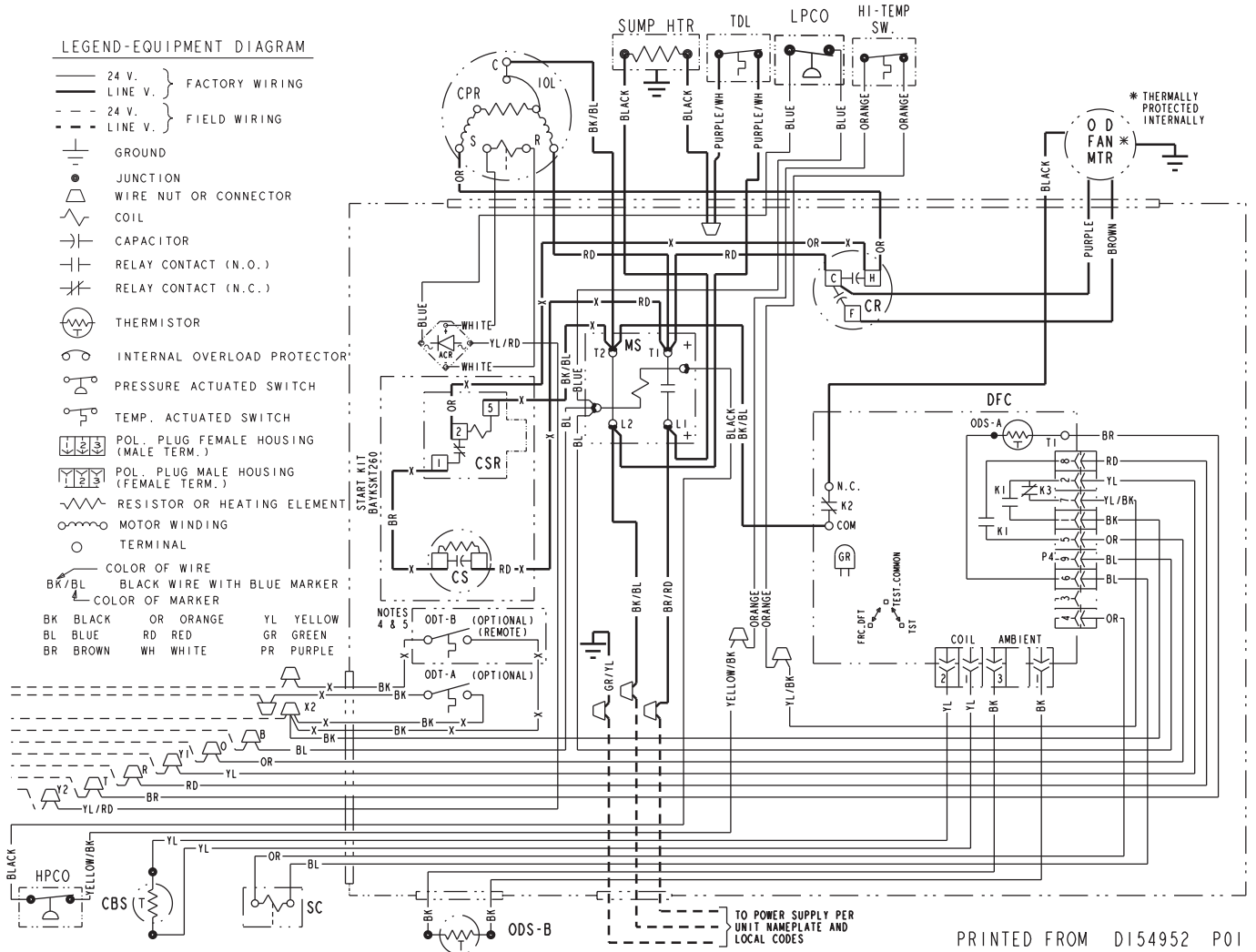

PRINTED FROM D154952 P01

**SUBCOOLING CHARGING  
BELOW 55°F OD AMBIENT –  
IN HEATING ONLY**

1. The Subcool Charging Method in cooling is not recommended below 55°F outdoor ambient.
2. The only recommended method of charging at outdoor ambients below 55°F, is to weigh in the charge in the heating mode.
3. Use Nameplate charge plus standard charge adders for line length.
4. Check liquid line temperature and pressure (at the OD valves) to obtain a minimum of 10°F subcooling.
5. Add charge if a minimum of 10°F subcooling is not obtained with the nameplate charge plus line length correction.
6. It is important to return in the spring or summer to accurately charge the system in the cooling mode at outdoor ambients above 55°F.

R-410A REFRIGERANT CHARGING CHART							
LIQUID TEMP (°F)	DESIGN SUBCOOLING (°F)						
	8	9	10	11	12	13	14
	LIQUID GAGE PRESSURE (PSI)						
55	179	182	185	188	191	195	198
60	195	198	201	204	208	211	215
65	211	215	218	222	225	229	232
70	229	232	236	240	243	247	251
75	247	251	255	259	263	267	271
80	267	271	275	279	283	287	291
85	287	291	296	300	304	309	313
90	309	313	318	322	327	331	336
95	331	336	341	346	351	355	360
100	355	360	365	370	376	381	386
105	381	386	391	396	402	407	413
110	407	413	418	424	429	435	441
115	435	441	446	452	458	464	470
120	464	470	476	482	488	495	501
125	495	501	507	514	520	527	533
Refer to Service Facts or Installer's Guide for charging method.							

**PRESSURE CURVES FOR 4TWX6048B1000B**  
**4TEE3F49A** **4TEE3F49A**

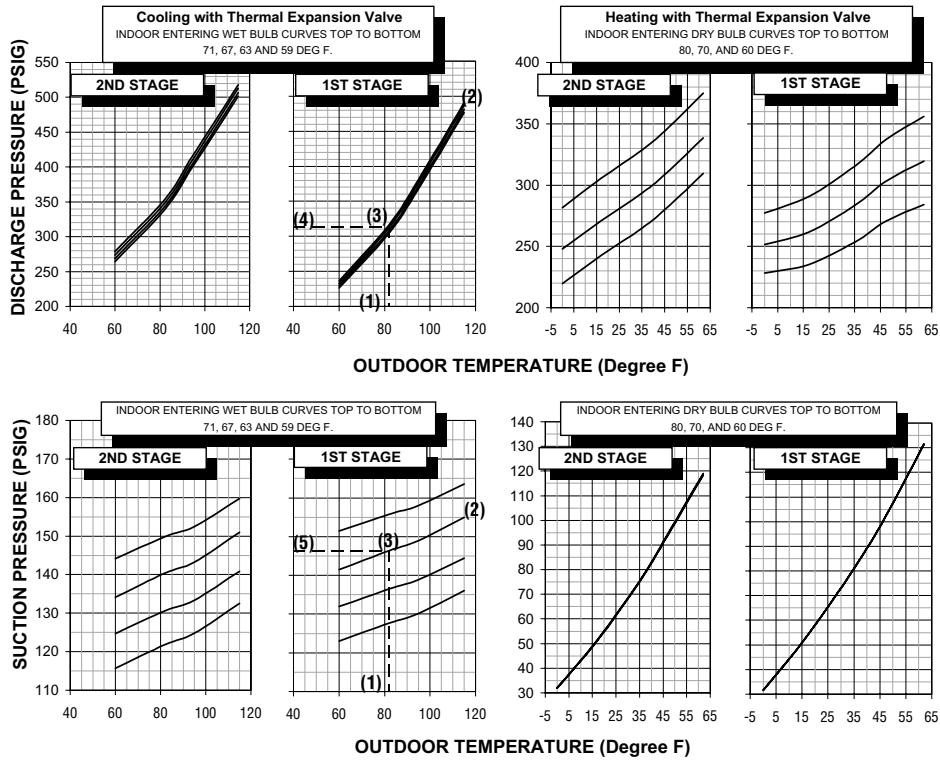

**COOLING PERFORMANCE CAN BE CHECKED WHEN THE OUTDOOR TEMP IS ABOVE 65 DEG F.**  
 TO CHECK COOLING PERFORMANCE, SELECT THE PROPER INDOOR CFM, ALLOW PRESSURES TO STABILIZE. MEASURE INDOOR WET BULB TEMPERATURE, OUTDOOR TEMPERATURE, DISCHARGE AND SUCTION PRESSURES. ON THE PLOTS LOCATE OUTDOOR TEMPERATURE (1); LOCATE INDOOR WET BULB (2); FIND INTERSECTION OF OD TEMP. & ID W.B. (3); READ DISCHARGE OR SUCTION PRESSURE IN LEFT COLUMN (4).

EXAMPLE: (1) OUTDOOR TEMP. 82 F.  
 (2) INDOOR WET BULB 67 F.  
 (3) AT INTERSECTION  
 (4) DISCHARGE PRESSURE @ 1240 CFM IS 312 PSIG  
 (5) SUCTION PRESSURE @ 1600 CFM IS 146 PSIG.

ACTUAL:  
 DISCHARGE PRESSURE SHOULD BE +/- 10 PSI OF CHART  
 SUCTION PRESSURE SHOULD BE +/- 3 PSIG OF CHART

INTERCONNECTING LINES  
 GAS - 7/8" O.D.  
 LIQUID - 3/8" O.D.

DWG.NO. 4TWX6048B1

**REFRIGERANT CIRCUIT**

