

Service Facts



X341001P14

Gas Furnaces Upflow & Downflow – Induced Draft 1 Stage Heat

***UE-SF-1A**

Models:

*UE1A040A9241A
*UE1A060A9241A
*UE1A060A9361A
*UE1B060A9361A
*UE1B080A9361A

*UE1B080A9481A
*UE1B100A9361A
*UE1C100A9481A
*UE1C100A9601A

*UE1D120A9601A
*UE1D140A9601A
*DE1A060A9361A
*DE1B060A9361A

*DE1B080A9451A
*DE1B100A9451A
*DE1C100A9601A
*DE1D120A9601A

*May be "A" or "T"

B - FURNACES

IMPORTANT — This document contains a wiring diagram and service information. This is customer property and is to remain with this unit. Please return to service information pack upon completion of work.

⚠ WARNING DISCONNECT POWER BEFORE SERVICING

PRODUCT SPECIFICATIONS ①

MODEL	*UE1A040A9241A	*UE1A060A9241A	*UE1A060A9361A	*UE1B060A9361A
TYPE	Upflow / Horizontal	Upflow / Horizontal	Upflow / Horizontal	Upflow / Horizontal
RATINGS ②				
Input BTUH ③	40,000	60,000	60,000	60,000
Capacity BTUH (ICS) ③	31,000	47,000	47,000	47,000
Temp. rise (Min.-Max.) °F.	30 - 60	30 - 60	30 - 60	30 - 60
BLOWER DRIVE				
Diameter - Width (In.)	Direct 10 x 6	Direct 10 x 6**	Direct 10 x 6**	Direct 10 x 6**
No. Used	1	1	1	1
Speeds (No.)	4	4	4	4
CFM vs. in. w.g.	See Fan Performance Table	See Fan Performance Table	See Fan Performance Table	See Fan Performance Table
Motor HP	1/5	1/3	1/3	1/3
R.P.M.	1080	1075	1075	1075
Volts / Ph / Hz	115/1/60	115/1/60	115/1/60	115/1/60
COMBUSTION FAN - Type				
Drive - No. Speeds	Centrifugal Direct - 1	Centrifugal Direct - 1	Centrifugal Direct - 1	Centrifugal Direct - 1
Motor HP - RPM	1/50 - 3180	1/50 - 3180	1/50 - 3180	1/50 - 3180
Volts / Ph / Hz	115/1/60	115/1/60	115/1/60	115/1/60
FLA	1.09	1.09	1.09	1.09
FILTER — Furnished?				
Type Recommended	No	No	No	No
Hi Vel. (No.-Size-Thk.)	High Velocity 1 - 16x25 - 1 in.	High Velocity 1 - 16x25 - 1 in.	High Velocity 1 - 16x25 - 1 in.	High Velocity 1 - 16x25 - 1 in.
VENT — Size (in.)				
	4 Round	4 Round	4 Round	4 Round
HEAT EXCHANGER				
Type - Fired	Alum. Steel	Alum. Steel	Alum. Steel	Alum. Steel
- Unfired	-	-	-	-
Gauge (Fired)	20	20	20	20
ORIFICES — Main				
Nat. Gas. Qty. — Drill Size	2 — 45	3 — 45	3 — 45	3 — 45
L.P. Gas Qty. — Drill Size	2 — 56	3 — 56	3 — 56	3 — 56
GAS VALVE				
	Redundant - Single Stage	Redundant - Single Stage	Redundant - Single Stage	Redundant - Single Stage
PILOT SAFETY DEVICE				
Type	Hot Surface Ignition	Hot Surface Ignition	Hot Surface Ignition	Hot Surface Ignition
BURNERS — Type				
Number	Multiport Inshot 2	Multiport Inshot 3	Multiport Inshot 3	Multiport Inshot 3
POWER CONN. — V / Ph / Hz ④				
Ampacity (In Amps)	115/1/60 5.4	115/1/60 9.0	115/1/60 9.0	115/1/60 9.0
Max. Overcurrent Protection (Amps)	15	15	15	15
PIPE CONN. SIZE (IN.)				
	1/2	1/2	1/2	1/2
DIMENSIONS				
Crated (In.)	H x W x D 41-3/4 x 16-1/2 x 30-1/2	H x W x D 41-3/4 x 16-1/2 x 30-1/2	H x W x D 41-3/4 x 16-1/2 x 30-1/2	H x W x D 41-3/4 x 16-1/2 x 30-1/2
WEIGHT				
Shipping (Lbs.) / Net (Lbs.)	119 / 110	127 / 118	127 / 118	137 / 127

**TUE1B060A9361A was built with a 10 X 7 blower housing, however the 10 X 7 and 10 X 6 have identical airflow in this model.

① Central Furnace heating designs are certified by AGA and CSA.

② For U.S. applications, above input ratings (BTUH) are up to 2,000 feet, derate 4% per 1,000 feet for elevations above 2,000 feet above sea level. For Canadian applications, above input ratings (BTUH) are up to 4,500 feet, derate 4% per 1,000 feet for elevations above 4,500 feet above sea level.

③ Based on U.S. government standard tests.

④ The above wiring specifications are in accordance with National Electrical Code; however, installations must comply with local codes.

NOTICE: Since the manufacturer has a policy of continuous product and product data improvement, it reserves the right to change design and specifications without notice.

X341001P14

9/07

Service Facts

PRODUCT SPECIFICATIONS ①

MODEL	*UE1B080A9361A	*UE1B080A9481A	*UE1B100A9361A	*UE1C100A9481A
TYPE	Upflow / Horizontal	Upflow / Horizontal	Upflow / Horizontal	Upflow / Horizontal
RATINGS ②				
Input BTUH ③	80,000	80,000	100,000	100,000
Capacity BTUH (ICS) ③	63,000	64,000	79,000	79,000
Temp. rise (Min.-Max.) °F.	30 - 60	30 - 60	40 - 70	35 - 65
BLOWER DRIVE	Direct	Direct	Direct	Direct
Diameter - Width (In.)	10 x 7	10 x 8	10 x 7	10 x 8
No. Used	1	1	1	1
Speeds (No.)	4	4	4	4
CFM vs. in. w.g.	See Fan Performance Table	See Fan Performance Table	See Fan Performance Table	See Fan Performance Table
Motor HP	1/3	1/3	1/3	1/2
R.P.M.	1075	1075	1075	1075
Volts / Ph / Hz	115/1/60	115/1/60	115/1/60	115/1/60
COMBUSTION FAN - Type	Centrifugal	Centrifugal	Centrifugal	Centrifugal
Drive - No. Speeds	Direct - 1	Direct - 1	Direct - 1	Direct - 1
Motor HP - RPM	1/50 - 3180	1/50 - 3180	1/50 - 3180	1/50 - 3180
Volts / Ph / Hz	115/1/60	115/1/60	115/1/60	115/1/60
FLA	1.09	1.09	1.09	1.09
FILTER — Furnished?	No	No	No	No
Type Recommended	High Velocity	High Velocity	High Velocity	High Velocity
Hi Vel. (No.-Size-Thk.)	1 - 17x25 - 1 in.	1 - 17x25 - 1 in.	1 - 17x25 - 1 in.	1 - 20x25 - 1 in.
VENT — Size (in.)	4 Round	4 Round	4 Round	4 Round
HEAT EXCHANGER				
Type - Fired	Alum. Steel	Alum. Steel	Alum. Steel	Alum. Steel
- Unfired				
Gauge (Fired)	20	20	20	20
ORIFICES — Main				
Nat. Gas Qty. — Drill Size	4 — 45	4 — 45	5 — 45	5 — 45
L.P. Gas Qty. — Drill Size	4 — 56	4 — 56	5 — 56	5 — 56
GAS VALVE	Redundant - Single Stage	Redundant - Single Stage	Redundant - Single Stage	Redundant - Single Stage
PILOT SAFETY DEVICE				
Type	Hot Surface Ignition	Hot Surface Ignition	Hot Surface Ignition	Hot Surface Ignition
BURNERS — Type	Multiport Inshot	Multiport Inshot	Multiport Inshot	Multiport Inshot
Number	4	4	5	5
POWER CONN. — V / Ph / Hz ④	115/1/60	115/1/60	115/1/60	115/1/60
Ampacity (In Amps)	9.0	9.8	9.0	11.6
Max. Overcurrent Protection (Amps)	15	15	15	15
PIPE CONN. SIZE (IN.)	1/2	1/2	1/2	1/2
DIMENSIONS	H x W x D	H x W x D	H x W x D	H x W x D
Crated (In.)	41-3/4 x 19-1/2 x 30-1/2	41-3/4 x 19-1/2 x 30-1/2	41-3/4 x 19-1/2 x 30-1/2	41-3/4 x 23 x 30-1/2
WEIGHT				
Shipping (Lbs.) / Net (Lbs.)	142 / 132	142 / 132	151 / 141	162 / 151

① Central Furnace heating designs are certified by AGA and CSA.

② For U.S. applications, above input ratings (BTUH) are up to 2,000 feet, derate 4% per 1,000 feet for elevations above 2,000 feet above sea level. For Canadian applications, above input ratings (BTUH) are up to 4,500 feet, derate 4% per 1,000 feet for elevations above 4,500 feet above sea level.

③ Based on U.S. government standard tests.

④ The above wiring specifications are in accordance with National Electrical Code; however, installations must comply with local codes.

MODEL	*UE1C100A9601A	*UE1D120A9601A	*UE1D140A9601A
TYPE	Upflow / Horizontal	Upflow / Horizontal	Upflow / Horizontal
RATINGS ②			
Input BTUH ③	100,000	120,000	140,000
Capacity BTUH (ICS) ③	79,000	96,000	111,000
Temp. rise (Min.-Max.) °F.	30 - 60	30 - 60	40 - 70
BLOWER DRIVE	Direct	Direct	Direct
Diameter - Width (In.)	11 x 10	11 x 10	11 x 10
No. Used	1	1	1
Speeds (No.)	4	4	4
CFM vs. in. w.g.	See Fan Performance Table	See Fan Performance Table	See Fan Performance Table
Motor HP	1/2	1/2	3/4
R.P.M.	1075	1075	1075
Volts / Ph / Hz	115/1/60	115/1/60	115/1/60
COMBUSTION FAN - Type	Centrifugal	Centrifugal	Centrifugal
Drive - No. Speeds	Direct - 1	Direct - 1	Direct - 1
Motor HP - RPM	1/50 - 3180	1/50 - 3180	1/50 - 3180
Volts / Ph / Hz	115/1/60	115/1/60	115/1/60
FLA	1.09	1.09	1.09
FILTER — Furnished?	No	No	No
Type Recommended	High Velocity	High Velocity	High Velocity
Hi Vel. (No.-Size-Thk.)	1 - 20x25 - 1 in.	1 - 24x25 - 1 in.	1 - 24x25 - 1 in.
VENT — Size (in.)	4 Round	4 Round	4 Round
HEAT EXCHANGER			
Type - Fired	Alum. Steel	Alum. Steel	Alum. Steel
- Unfired			
Gauge (Fired)	20	20	20
ORIFICES — Main			
Nat. Gas Qty. — Drill Size	5 — 45	6 — 45	7 — 45
L.P. Gas Qty. — Drill Size	5 — 56	6 — 56	7 — 56
GAS VALVE	Redundant - Single Stage	Redundant - Single Stage	Redundant - Single Stage
PILOT SAFETY DEVICE			
Type	Hot Surface Ignition	Hot Surface Ignition	Hot Surface Ignition
BURNERS — Type	Multiport Inshot	Multiport Inshot	Multiport Inshot
Number	5	6	7
POWER CONN. — V / Ph / Hz ④	115/1/60	115/1/60	115/1/60
Ampacity (In Amps)	13.4	13.4	13.8
Max. Overcurrent Protection (Amps)	20	20	20
PIPE CONN. SIZE (IN.)	1/2	1/2	1/2
DIMENSIONS	H x W x D	H x W x D	H x W x D
Crated (In.)	41-3/4 x 23 x 30-1/2	41-3/4 x 26-1/2 x 30-1/2	41-3/4 x 26-1/2 x 30-1/2
WEIGHT			
Shipping (Lbs.) / Net (Lbs.)	162 / 151	186 / 174	193 / 181

*May be "A" or "T"

PRODUCT SPECIFICATIONS ①

MODEL	*DE1A060A9361A	*DE1B060A9361A	*DE1B080A9451A
TYPE	Downflow / Horizontal	Downflow / Horizontal	Downflow / Horizontal
RATINGS ②			
Input BTUH ③	60,000	60,000	80,000
Capacity BTUH (ICS) ③	48,000	48,000	64,000
Temp. rise (Min.-Max.) °F.	30 - 60	30 - 60	35 - 65
BLOWER DRIVE	DIRECT	DIRECT	DIRECT
Diameter - Width (In.)	10 x 7	10 x 7	10 x 8
No. Used	1	1	1
Speeds (No.)	4	4	4
CFM vs. in. w.g.	See Fan Performance Table	See Fan Performance Table	See Fan Performance Table
Motor HP	1/2	1/2	1/3
R.P.M.	1075	1075	1075
Volts / Ph / Hz	115/1/60	115/1/60	115/1/60
COMBUSTION FAN - Type	Centrifugal	Centrifugal	Centrifugal
Drive - No. Speeds	Direct - 1	Direct - 1	Direct - 1
Motor HP - RPM	1/50 - 3180	1/50 - 3180	1/50 - 3180
Volts / Ph / Hz	115/1/60	115/1/60	115/1/60
FLA	1.09	1.09	1.09
FILTER — Furnished?	No	No	No
Type Recommended	High Velocity	High Velocity	High Velocity
Hi Vel. (No.-Size-Thk.)	2 - 14x20 - 1 in.	2 - 14x20 - 1 in.	2 - 14x20 - 1 in.
VENT — Size (in.)	4 Round	4 Round	4 Round
HEAT EXCHANGER			
Type - Fired	Alum. Steel - Type I	Alum. Steel - Type I	Alum. Steel - Type I
- Unfired			
Gauge (Fired)	20	20	20
ORIFICES — Main			
Nat. Gas Qty. — Drill Size	3 — 45	3 — 45	4 — 45
L.P. Gas Qty. — Drill Size	3 — 56	3 — 56	4 — 56
GAS VALVE	Redundant - Single Stage	Redundant - Single Stage	Redundant - Single Stage
PILOT SAFETY DEVICE			
Type	Hot Surface Ignition	Hot Surface Ignition	Hot Surface Ignition
BURNERS — Type	Multiport Inshot	Multiport Inshot	Multiport Inshot
Number	3	3	4
POWER CONN. — V / Ph / Hz ④	115/1/60	115/1/60	115/1/60
Ampacity (In Amps)	11.2	11.2	9.1
Max. Overcurrent Protection (Amps)	15	15	15
PIPE CONN. SIZE (IN.)	1/2	1/2	1/2
DIMENSIONS	H x W x D	H x W x D	H x W x D
Crated (In.)	41-3/4 x 16-1/2 x 30-1/2	41-3/4 x 16-1/2 x 30-1/2	41-3/4 x 19-1/2 x 30-1/2
WEIGHT			
Shipping (Lbs.) / Net (Lbs.)	129 / 119	129 / 119	146 / 135

① Central Furnace heating designs are certified by AGA and CSA.

② For U.S. applications, above input ratings (BTUH) are up to 2,000 feet, derate 4% per 1,000 feet for elevations above 2,000 feet above sea level. For Canadian applications, above input ratings (BTUH) are up to 4,500 feet, derate 4% per 1,000 feet for elevations above 4,500 feet above sea level.

③ Based on U.S. government standard tests.

④ The above wiring specifications are in accordance with National Electrical Code; however, installations must comply with local codes.

MODEL	*DE1B100A9451A	*DE1C100A9601A	*DE1D120A9601A
TYPE	Downflow / Horizontal	Downflow / Horizontal	Downflow / Horizontal
RATINGS ②			
Input BTUH ③	100,000	100,000	120,000
Capacity BTUH (ICS) ③	80,000	80,000	96,000
Temp. rise (Min.-Max.) °F.	35 - 65	30 - 60	35 - 65
BLOWER DRIVE	DIRECT	DIRECT	DIRECT
Diameter - Width (In.)	10 x 8	11 x 10	11 x 10
No. Used	1	1	1
Speeds (No.)	4	4	4
CFM vs. in. w.g.	See Fan Performance Table	See Fan Performance Table	See Fan Performance Table
Motor HP	1/3	1/2	1/2
R.P.M.	1075	1075	1075
Volts / Ph / Hz	115/1/60	115/1/60	115/1/60
COMBUSTION FAN - Type	Centrifugal	Centrifugal	Centrifugal
Drive - No. Speeds	Direct - 1	Direct - 1	Direct - 1
Motor HP - RPM	1/50 - 3180	1/50 - 3180	1/50 - 3180
Volts / Ph / Hz	115/1/60	115/1/60	115/1/60
FLA	1.09	1.09	1.09
FILTER — Furnished?	No	No	No
Type Recommended	High Velocity	High Velocity	High Velocity
Hi Vel. (No.-Size-Thk.)	2 - 14x20 - 1 in.	2 - 16x20 - 1 in.	2 - 16x20 - 1 in.
VENT — Size (in.)	4 Round	4 Round	4 Round
HEAT EXCHANGER			
Type - Fired	Alum. Steel - Type I	Alum. Steel - Type I	Alum. Steel - Type I
- Unfired			
Gauge (Fired)	20	20	20
ORIFICES — Main			
Nat. Gas Qty. — Drill Size	5 — 45	5 — 45	6 — 45
L.P. Gas Qty. — Drill Size	5 — 56	5 — 56	6 — 56
GAS VALVE	Redundant - Single Stage	Redundant - Single Stage	Redundant - Single Stage
PILOT SAFETY DEVICE			
Type	Hot Surface Ignition	Hot Surface Ignition	Hot Surface Ignition
BURNERS — Type	Multiport Inshot	Multiport Inshot	Multiport Inshot
Number	5	5	6
POWER CONN. — V / Ph / Hz ④	115/1/60	115/1/60	115/1/60
Ampacity (In Amps)	9.1	12.8	12.8
Max. Overcurrent Protection (Amps)	15	15	15
PIPE CONN. SIZE (IN.)	1/2	1/2	1/2
DIMENSIONS	H x W x D	H x W x D	H x W x D
Crated (In.)	41-3/4 x 19-1/2 x 30-1/2	41-3/4 x 23 x 30-1/2	41-3/4 x 26-1/2 x 30-1/2
WEIGHT			
Shipping (Lbs.) / Net (Lbs.)	156 / 145	167 / 155	189 / 176

*May be "A" or "T"

X341001P14

Service Facts

SAFETY SECTION

WARNING

CARBON MONOXIDE POISONING HAZARD

Failure to follow the steps outlined below for each appliance connected to the venting system being placed into operation could result in carbon monoxide poisoning or death.

The following steps shall be followed for each appliance connected to the venting system being placed into operation, while all other appliances connected to the venting system are not in operation:

1. Seal any unused openings in the venting system.
2. Inspect the venting system for proper size and horizontal pitch, as required in the National Fuel Gas Code, ANSI Z223.1/NFPA 54 or the CAN/CGA B149 Installation Codes and these instructions. Determine that there is no blockage or restriction, leakage, corrosion and other deficiencies which could cause an unsafe condition.
3. As far as practical, close all building doors and windows and all doors between the space in which the appliance(s) connected to the venting system are located and other deficiencies which could cause an unsafe condition.
4. Close fireplace dampers.
5. Turn on clothes dryers and any appliance not connected to the venting system. Turn on any exhaust fans, such as range hoods and bathroom exhausts, so they are operating at maximum speed. Do not operate a summer exhaust fan.
6. Follow the lighting instructions. Place the appliance being inspected into operation. Adjust the thermostat so appliance is operating continuously.
7. If improper venting is observed during any of the above tests, the venting system must be corrected in accordance with the National Fuel Gas Code, ANSI Z221.1/NFPA 54 and/or CAN/CGA B149 Installation Codes.
8. After it has been determined that each appliance connected to the venting system properly vents where tested as outlined above, return doors, windows, exhaust fans, fireplace dampers and any other gas-fired burning appliance to their previous conditions of use.

WARNING

The cabinet must have an uninterrupted or unbroken ground according to National Electrical Code, ANSI/NFPA 70 - "latest edition" and Canadian Electrical Code, CSA C22.1 or local codes to minimize personal injury if an electrical fault should occur. A failure to follow this warning could result in an electrical shock, fire, injury, or death.

CAUTION

The integrated furnace control is polarity sensitive. The hot leg of the 115 VAC power must be connected to the BLACK field lead.

WARNING

FIRE OR EXPLOSION HAZARD

Failure to follow the safety warnings exactly could result in serious injury, death or property damage.

Never test for gas leaks with an open flame. Use a commercially available soap solution made specifically for the detection of leaks to check all connections. A fire or explosion may result causing property damage, personal injury, or loss of life.

WARNING

FIRE OR EXPLOSION HAZARD

Failure to follow the safety warnings exactly could result in serious injury, death or property damage.

Improper servicing could result in dangerous operation, serious injury, death, or property damage.

SEQUENCE OF OPERATION

THERMOSTAT CALL FOR HEAT

R and W thermostat contacts close signaling the control module to run its self-check routine. After the control module has verified that the pressure switch contacts are open and the limit switch(es) contacts are closed, the draft blower will be energized.

As the induced draft blower comes up to speed, the pressure switch contacts will close and the ignitor warm up period will begin. The ignitor will heat for approx. 17 seconds, then the gas valve is energized to permit gas flow to the burners. The flame sensor confirms that ignition has been achieved within the 4 second ignition trial period.

After the flame sensor confirms that ignition has been achieved, the delay to fan ON period begins timing and after approx. 45 seconds the indoor blower motor will be energized and will continue to run during the heating cycle.

When the thermostat is satisfied, R and W thermostat contacts open, the gas valve will close, the flames will extinguish, and the induced draft blower will be de-energized. The indoor blower motor will continue to run for the fan off period (Field selectable at 60, 100, 140 or 180 seconds), then will be de-energized by the control module.

PERIODIC SERVICING REQUIREMENTS

1. GENERAL INSPECTION — Examine the furnace installation annually for the following items:
 - a. All flue product carrying areas external to the furnace (i.e. chimney, vent connector) are clear and free of obstruction. A vent screen in the end of the vent (flue) pipe must be inspected for blockage annually.
 - b. The vent connector is in place, slopes upward and is physically sound without holes or excessive corrosion.
 - c. The return air duct connection(s) is physically sound, is sealed to the furnace and terminates outside the space containing the furnace.
 - d. The physical support of the furnace should be sound without sagging, cracks, gaps, etc., around the base so as to provide a seal between the support and the base.
 - e. There are no obvious signs of deterioration of the furnace.
2. FILTERS — Filters should be cleaned or replaced (with high velocity filters only), monthly and more frequently during high use times of the year such as midsummer or midwinter.
3. BLOWERS — The blower size and speed determine the air volume delivered by the furnace. The blower motor bearings are factory lubricated and under normal operating conditions do not require servicing. If motor lubrication is required it should only be done by a qualified servicer. Annual cleaning of the blower wheel and housing is recommended for maximum air output, and this must be performed only by a qualified servicer or service agency.
4. IGNITER — This unit has a special hot surface direct ignition device that automatically lights the burners. Please note that it is very fragile and should be handled with care.

WARNING

Do not touch igniter. It is extremely hot. Failure to follow this warning could result in severe burns.

5. BURNER — Gas burners do not normally require scheduled servicing, however, accumulation of foreign material may cause a yellowing flame or delayed ignition. Either condition indicates that a service call is required. For best operation, burners must be cleaned annually using brushes and vacuum cleaner.

Turn off gas and electric power supply. To clean burners, remove the top burner bracket. Lift burners from orifices.

NOTE:

Be careful not to break igniter when removing burners.

Clean burners with brush and/or vacuum cleaner. Reassemble parts by reversal of the above procedure.

NOTE:

On LP (propane) units, some light yellow tipping of the outer mantle is normal. Inner mantle should be bright blue.

Natural gas units should not have any yellow tipped flames. This condition indicates that a service call is required. For best operation, burners must be cleaned annually using brushes and vacuum cleaner.

NOTE:

On LP (propane) units, due to variations in BTU content and altitude, servicing may be required at shorter intervals.

WARNING

CARBON MONOXIDE POISONING HAZARD

Failure to follow the installation instructions for the venting system being placed into operation could result in carbon monoxide poisoning or death.

6. HEAT EXCHANGER/FLUE PIPE — These items must be inspected for signs of corrosion, and/or deterioration at the beginning of each heating season by a qualified service technician and cleaned annually for best operation. To clean flue gas passages, follow recommendations below:
 - a. Turn off gas and electric power supply.
 - b. Inspect flue pipe exterior for cracks, leaks, holes or leaky joints.
 - c. Remove burner compartment door from furnace.
 - d. Inspect around insulation covering flue collector box. Inspect induced draft blower connections to the flue pipe connection.
 - e. Remove burners. (See 4.)
 - f. Use a mirror and flashlight to inspect interior of heat exchanger, be careful not to damage the igniter, flame sensor or other components.
 - g. If any corrosion is present, contact a service agency. Heat exchanger should be cleaned by a qualified service technician.
 - h. After inspection is complete replace burners and furnace door.
 - i. Restore gas supply. Check for leaks using a soap solution. Restore electrical supply. Check unit for normal operation.

WARNING

FIRE OR EXPLOSION HAZARD

Failure to follow the safety warnings exactly could result in serious injury, death or property damage.

Never test for gas leaks with an open flame. Use a commercially available soap solution made specifically for the detection of leaks to check all connections. A fire or explosion may result causing property damage, personal injury, or loss of life.

7. COOLING COIL CONDENSATE DRAIN — If a cooling coil is installed with the furnace, condensate drains should be checked and cleaned periodically to assure that condensate can drain freely from coil to drain. If condensate cannot drain freely water damage could occur. (See Condensate Drain in Installer's Guide)

CAUTION

Label all wires prior to disconnection when servicing controls. Wiring errors can cause improper and dangerous operation.

Verify proper operation after servicing.

Service Facts

WIRING DIAGRAM

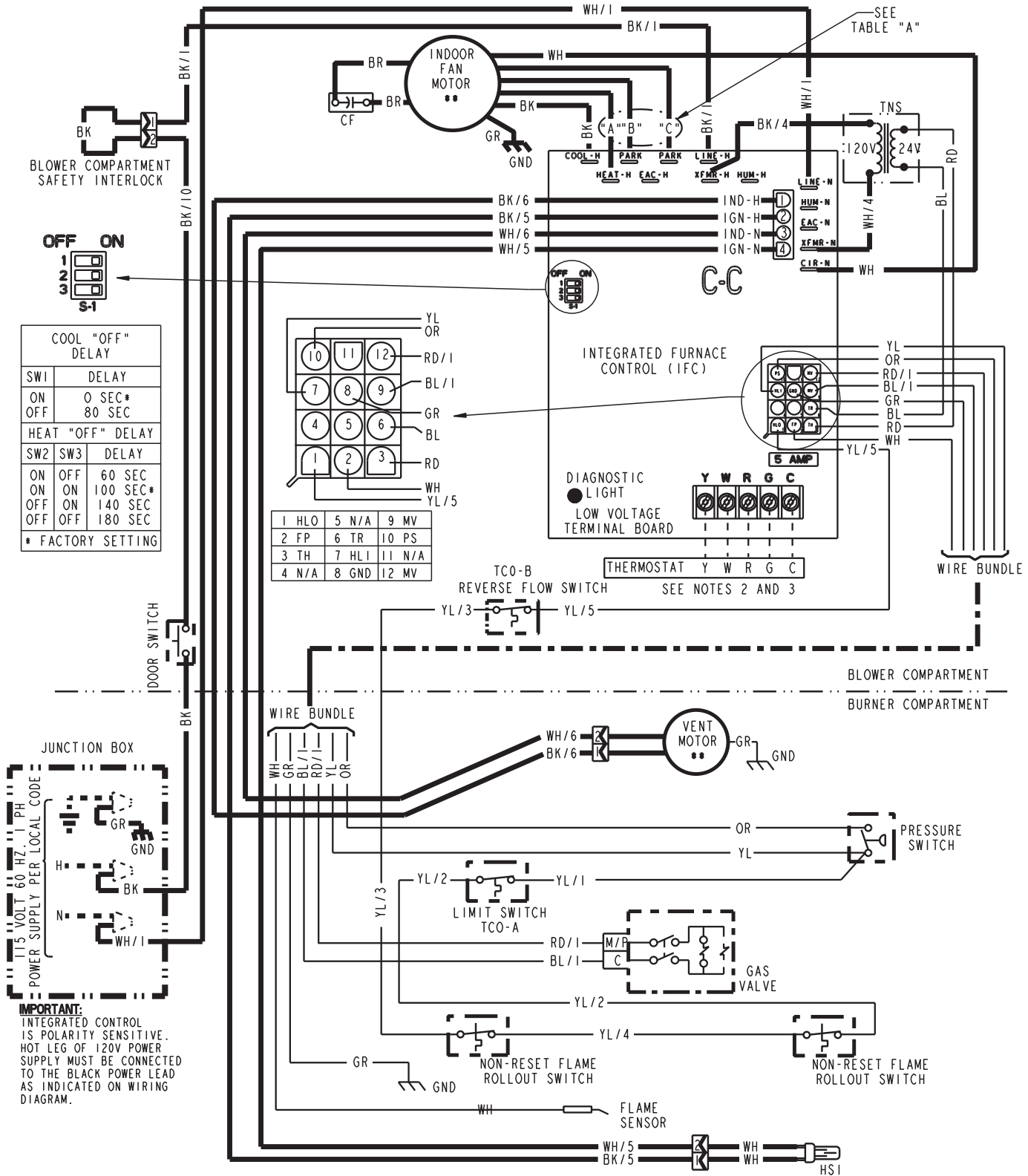

From Dwg. D342780 Rev. 1

(continued on next page)

SCHEMATIC DIAGRAM

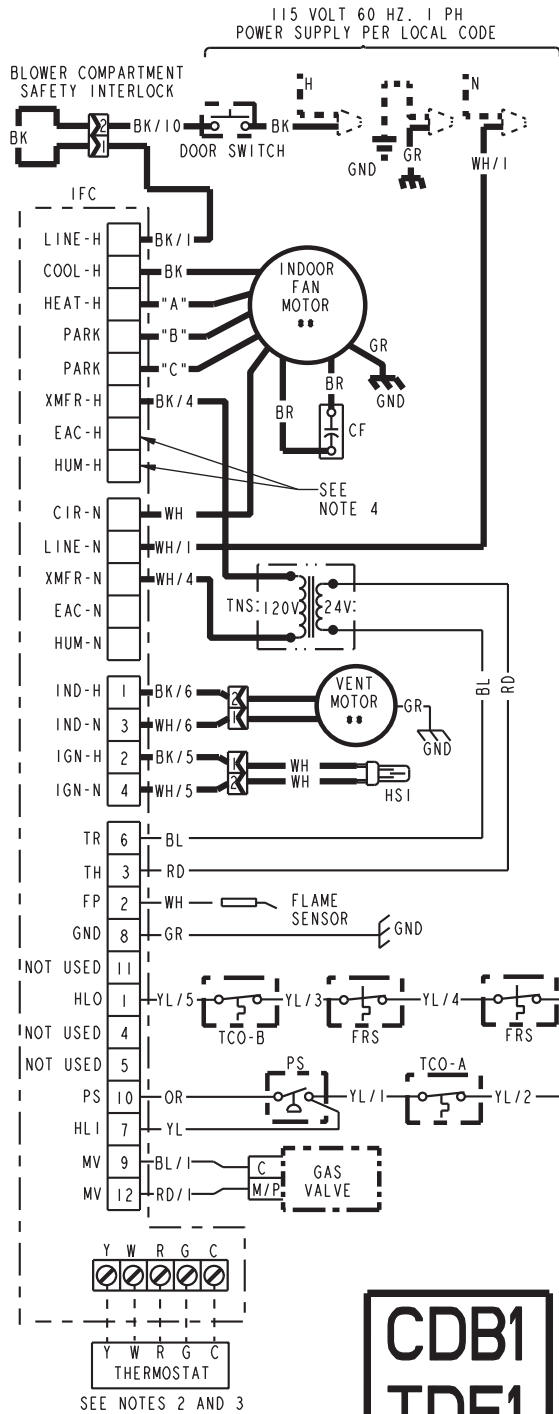

**CDB1
TDE1
ADE1**

D342780P01 REV01

MODEL	HEAT "A"	PARK "B"	PARK "C"
CDB1A060A9361A*	YL	RD	BL
TDE1A060A9361A*			
ADE1A060A9361A*			
CDB1B060A9361A*	RD	BL	YL
TDE1B060A9361A*			
ADE1B060A9361A*			
CDB1B080A9451A*	BL	RD	YL
TDE1B080A9451A*			
ADE1B080A9451A*			
CDB1B100A9451A*	BL	RD	YL
TDE1B100A9451A*			
ADE1B100A9451A*			
CDB1C100A9601A*	YL	RD	BL
TDE1C100A9601A*			
ADE1C100A9601A*			
CDB1D120A9601A*	BL	RD	YL
TDE1D120A9601A*			
ADE1D120A9601A*			

RD = LOW
YL = MED. LOW
BL = MED. HIGH
BK = HIGH
* - MAY BE A THROUGH Z

WARNING

HAZARDOUS VOLTAGE:
DISCONNECT ALL ELECTRICAL POWER INCLUDING REMOTE DISCONNECTS BEFORE SERVICING.
FAILURE TO DISCONNECT POWER BEFORE SERVICING CAN CAUSE SEVERE PERSONAL INJURY OR DEATH.

CAUTION

USE COPPER CONDUCTORS ONLY!
UNIT TERMINALS ARE NOT DESIGNED TO ACCEPT OTHER TYPES OF CONDUCTORS.
FAILURE TO DO SO MAY CAUSE DAMAGE TO THE EQUIPMENT.

INTEGRATED FURNACE CONTROL
REPLACE WITH PART CNT02891 OR CNT 02183 OR EQUIVALENT
INPUT: 25 VAC, 60 HZ.
XFMR SEC. CURRENT: 450 MA.
MV OUTPUT: 1.5 A @ 24 VAC
IND OUTPUT: 2.2 FLA, 3.5 LRA @ 120 VAC
CIRC. BLOWER OUTPUT: 14.5 FLA, 26 LRA @ 120 VAC
HUMIDIFIER & AIR CLEANER
MAX. LOAD: 1.0 A @ 120 VAC
IGNITER OUTPUT: 6.0 A @ 120 VAC

DIAGNOSTIC CODES

FLASHING SLOW: NORMAL - NO CALL FOR HEAT
FLASHING FAST: NORMAL - CALL FOR HEAT
CONTINUOUS ON: REPLACE IFC
CONTINUOUS OFF: CHECK POWER

2 FLASHES: EXTERNAL LOCKOUT (RETRIES OR RECYCLES EXCEEDED)
3 FLASHES: PRESSURE SWITCH ERROR
4 FLASHES: OPEN LIMIT DEVICE

5 FLASHES: FLAME SENSED WHEN NO FLAME SHOULD BE PRESENT
6 FLASHES: 115 VAC POWER REVERSED POLARITY OR POOR GROUNDING
7 FLASHES: GAS VALVE CIRCUIT ERROR
8 FLASHES: LOW FLAME SENSE SIGNAL

TCO THERMAL CUT OUT	LINE } FACTORY 24 V WIRING	<table border="1"> <tr> <td>BK BLACK</td> <td>GR GREEN</td> </tr> <tr> <td>WH WHITE</td> <td>BR BROWN</td> </tr> <tr> <td>YL YELLOW</td> <td>RD RED</td> </tr> <tr> <td>OR ORANGE</td> <td>BL BLUE</td> </tr> </table>	BK BLACK	GR GREEN	WH WHITE	BR BROWN	YL YELLOW	RD RED	OR ORANGE	BL BLUE				
BK BLACK	GR GREEN													
WH WHITE	BR BROWN													
YL YELLOW	RD RED													
OR ORANGE	BL BLUE													
PS PRESSURE SWITCH	LINE } FIELD 24 V WIRING													
FRS FLAME ROLLOUT SWITCH	** INTERNAL THERMAL PROTECTION	<table border="1"> <tr> <td>L LINE</td> <td>TH 24 VAC (HOT)</td> </tr> <tr> <td>N NEUTRAL</td> <td>TR 24 VAC (COMMON)</td> </tr> <tr> <td>GND GROUND</td> <td>MV MAIN GAS VALVE</td> </tr> <tr> <td>B/C COMMON</td> <td>TNS TRANSFORMER</td> </tr> <tr> <td>HLO HIGH LIMIT OUTPUT</td> <td></td> </tr> <tr> <td>HLI HIGH LIMIT INPUT</td> <td></td> </tr> </table>	L LINE	TH 24 VAC (HOT)	N NEUTRAL	TR 24 VAC (COMMON)	GND GROUND	MV MAIN GAS VALVE	B/C COMMON	TNS TRANSFORMER	HLO HIGH LIMIT OUTPUT		HLI HIGH LIMIT INPUT	
L LINE	TH 24 VAC (HOT)													
N NEUTRAL	TR 24 VAC (COMMON)													
GND GROUND	MV MAIN GAS VALVE													
B/C COMMON	TNS TRANSFORMER													
HLO HIGH LIMIT OUTPUT														
HLI HIGH LIMIT INPUT														
FP FLAME SENSOR	CF CAPACITOR													
CHASSIS GROUND	COIL													
HSI HOT SURFACE IGNITER														
DOOR SWITCH														

WIRE COLOR: BK/1 NUMBER 1D (IF ANY)

- NOTES:**
- IF ANY OF THE ORIGINAL WIRING AS SUPPLIED WITH THIS FURNACE MUST BE REPLACED, IT MUST BE WITH WIRE HAVING A TEMPERATURE RATING OF AT LEAST 105 C.
 - THERMOSTAT HEAT ANTICIPATOR SETTING: .38 AMPS
 - FOR PROPER OPERATION OF COOLING SPEED, "Y" TERMINAL MUST BE CONNECTED TO THE ROOM THERMOSTAT.
 - THESE TERMINALS PROVIDE 120V POWER CONNECTIONS FOR ELECTRONIC AIR CLEANER (EAC) AND HUMIDIFIER (HUM). MAX. LOAD: 1.0 AMPS EACH.

SCHEMATIC DIAGRAM

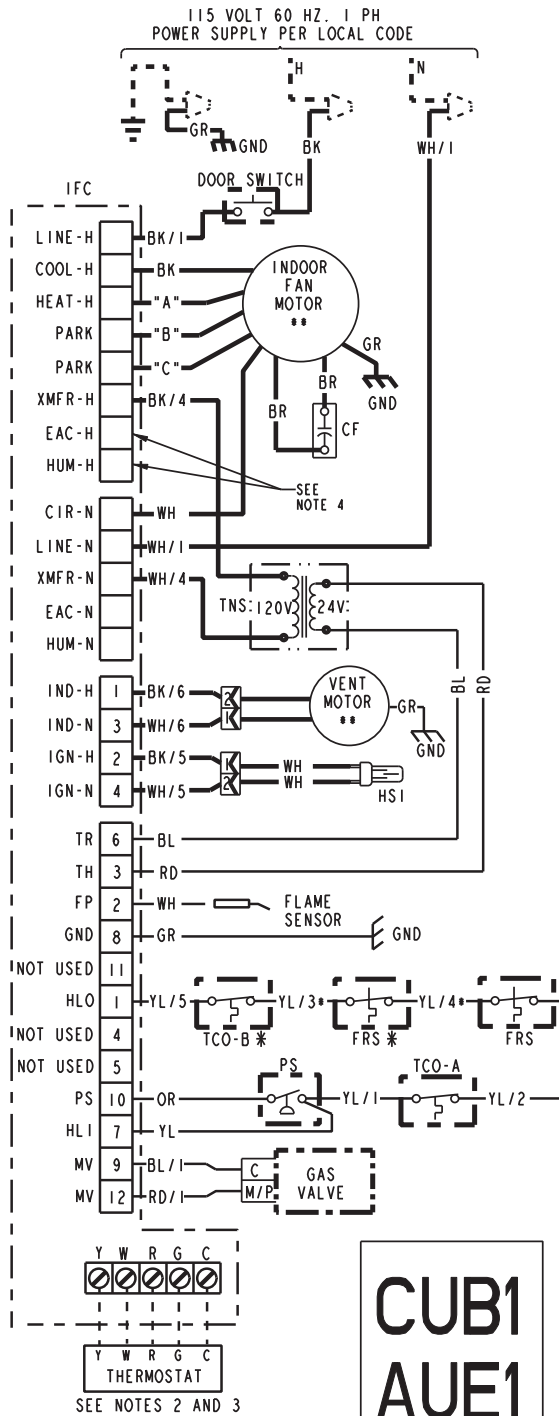

**CUB1
AUE1**

D342779P01 REV03

TABLE "A"			
SPEED TAPS FOR I. D. FAN MOTOR			
MODEL	HEAT "A"	PARK "B"	PARK "C"
CUB1A040A9241A*	YL	RD	BL
AUE1A040A9241A*			
CUB1A060A9241A*	BL	RD	YL
AUE1A060A9241A*			
CUB1A060A9361A*	YL	RD	BL
AUE1A060A9361A*			
CUB1B060A9361A*	RD	BL	YL
AUE1B060A9361A*			
CUB1B080A9361A*	BL	RD	YL
AUE1B080A9361A*			
CUB1B080A9481A*	BL	RD	YL
AUE1B080A9481A*			
CUB1B100A9361A*	BL	RD	YL
AUE1B100A9361A*			
CUB1C100A9481A*	BL	RD	YL
AUE1C100A9481A*			
CUB1C100A9601A*	YL	RD	BL
AUE1C100A9601A*			
CUB1D120A9601A*	BL	RD	YL
AUE1D120A9601A*			
CUB1D140A9601A*	BL	RD	YL
AUE1D140A9601A*			

* MAY BE A THROUGH Z
RD=LOW YL=MED. LOW BL=MED. HIGH BK=HIGH

WARNING
HAZARDOUS VOLTAGE:
DISCONNECT ALL ELECTRICAL POWER INCLUDING REMOTE DISCONNECTS BEFORE SERVICING.
FAILURE TO DISCONNECT POWER BEFORE SERVICING CAN CAUSE SEVERE PERSONAL INJURY OR DEATH.

CAUTION
USE COPPER CONDUCTORS ONLY!
UNIT TERMINALS ARE NOT DESIGNED TO ACCEPT OTHER TYPES OF CONDUCTORS.
FAILURE TO DO SO MAY CAUSE DAMAGE TO THE EQUIPMENT.

INTEGRATED FURNACE CONTROL
REPLACE WITH PART CNT02891 OR CNT 02183 OR EQUIVALENT
INPUT: 25 VAC, 60 HZ.
XFMR SEC. CURRENT: 450 MA.
MV OUTPUT: 1.5 A @ 24 VAC
IND OUTPUT: 2.2 FLA, 3.5 LRA @ 120 VAC
CIRC. BLOWER OUTPUT: 14.5 FLA, 26 LRA @ 120 VAC
HUMIDIFIER & AIR CLEANER
MAX. LOAD: 1.0 A @ 120 VAC
IGNITER OUTPUT: 6.0 A @ 120 VAC

DIAGNOSTIC CODES

FLASHING SLOW: NORMAL - NO CALL FOR HEAT
FLASHING FAST: NORMAL - CALL FOR HEAT
CONTINUOUS ON: REPLACE IFC
CONTINUOUS OFF: CHECK POWER
2 FLASHES: EXTERNAL LOCKOUT (RETRIES OR RECYCLES EXCEEDED)
3 FLASHES: PRESSURE SWITCH ERROR
4 FLASHES: OPEN LIMIT DEVICE
5 FLASHES: FLAME SENSED WHEN NO FLAME SHOULD BE PRESENT
6 FLASHES: 115 VAC POWER REVERSED POLARITY OR POOR GROUNDING
7 FLASHES: GAS VALVE CIRCUIT ERROR
8 FLASHES: LOW FLAME SENSE SIGNAL

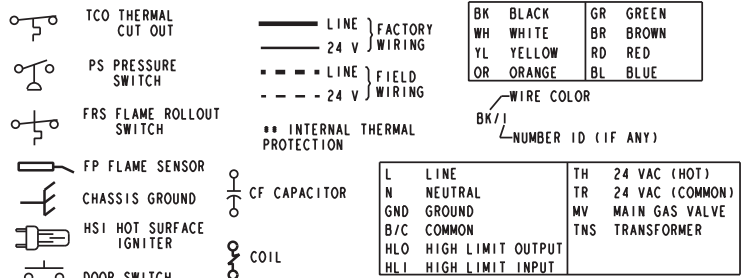

NOTES:

- IF ANY OF THE ORIGINAL WIRING AS SUPPLIED WITH THIS FURNACE MUST BE REPLACED, IT MUST BE WITH WIRE HAVING A TEMPERATURE RATING OF AT LEAST 105 C.
- THERMOSTAT HEAT ANTICIPATOR SETTING: .38 AMPS
- FOR PROPER OPERATION OF COOLING SPEED, "Y" TERMINAL MUST BE CONNECTED TO THE ROOM THERMOSTAT.
- THESE TERMINALS PROVIDE 120V POWER CONNECTIONS FOR ELECTRONIC AIR CLEANER (EAC) AND HUMIDIFIER (HUM). MAX. LOAD: 1.0 AMPS EACH.

From Dwg. D342779 Rev. 1

Service Facts

FURNACE AIRFLOW (CFM) VS. EXTERNAL STATIC PRESSURE (IN. W.C.)										
MODEL	SPEED TAP	0.10	0.20	0.30	0.40	0.50	0.60	0.70	0.80	0.90
*UE1A040A9241A	4 - HIGH - Black	1018	1004	982	950	910	860	802	763	660
	3 - MED.-HIGH - Blue	847	832	809	779	742	697	644	585	517
	2 - MED.-LOW - Yellow	716	701	678	648	610	585	512	452	384
	1 - LOW - Red	617	599	575	544	507	463	413	357	294
*UE1A060A9241A	4 - HIGH - Black	1018	997	973	941	901	852	796	731	659
	3 - MED.-HIGH - Blue	835	821	800	771	734	689	636	575	506
	2 - MED.-LOW - Yellow	712	702	683	655	617	571	516	452	379
	1 - LOW - Red	611	596	573	543	505	459	406	345	277
*UE1A060A9361A	4 - HIGH - Black	1426	1389	1345	1298	1236	1171	1099	1020	934
	3 - MED.-HIGH - Blue	1243	1225	1197	1160	1113	1057	991	916	831
	2 - MED.-LOW - Yellow	1042	1039	1027	1005	973	931	879	817	745
	1 - LOW - Red	900	903	895	877	848	809	760	700	629
*UE1B060A9361A	4 - HIGH - Black	1426	1389	1345	1298	1236	1171	1099	1020	934
	3 - MED.-HIGH - Blue	1243	1225	1197	1160	1113	1057	991	916	831
	2 - MED.-LOW - Yellow	1042	1039	1027	1005	973	931	879	817	745
	1 - LOW - Red	900	903	895	877	848	809	760	700	629
*UE1B080A9361A	4 - HIGH - Black	1393	1384	1364	1335	1296	1247	1189	1120	1042
	3 - MED.-HIGH - Blue	1210	1209	1198	1177	1147	1107	1058	999	930
	2 - MED.-LOW - Yellow	1046	1052	1047	1033	1008	973	928	873	808
	1 - LOW - Red	900	903	895	888	869	842	808	766	717
*UE1B100A9361A	4 - HIGH - Black	1476	1464	1441	1408	1363	1307	1241	1163	1074
	3 - MED.-HIGH - Blue	1249	1257	1252	1234	1203	1158	1101	1030	946
	2 - MED.-LOW - Yellow	1020	1046	1058	1050	1028	990	936	866	780
	1 - LOW - Red	873	887	890	883	864	834	794	742	680
*UE1B080A9481A	4 - HIGH - Black	1839	1821	1796	1756	1710	1641	1573	1480	1392
	3 - MED.-HIGH - Blue	1323	1325	1329	1319	1308	1275	1246	1201	1165
	2 - MED.-LOW - Yellow	1092	1090	1091	1083	1076	1059	1040	1005	970
	1 - LOW - Red	788	783	780	768	758	737	719	674	630
*UE1C100A9481A	4 - HIGH - Black	1880	1846	1799	1740	1669	1595	1489	1381	1260
	3 - MED.-HIGH - Blue	1662	1635	1598	1551	1493	1424	1345	1256	1157
	2 - MED.-LOW - Yellow	1428	1421	1402	1370	1326	1269	1199	1117	1022
	1 - LOW - Red	1208	1215	1210	1193	1164	1124	1073	1009	935
*UE1C100A9601A	4 - HIGH - Black	2181	2143	2104	2053	2001	1929	1856		1676
	3 - MED.-HIGH - Blue	1908	1888	1868	1834	1800	1745	1690		1572
	2 - MED.-LOW - Yellow	1621	1609	1597	1582	1567	1533	1498		1377
	1 - LOW - Red	1443	1419	1395	1381	1367	1335	1302	1256	1209
*UE1D120A9601A	4 - HIGH - Black	2135	2101	2066	2036	2005	1923	1840	1750	1659
	3 - MED.-HIGH - Blue	1906	1881	1856	1817	1777	1724	1671	1602	1533
	2 - MED.-LOW - Yellow	1646	1632	1617	1596	1575	1535	1494	1427	1360
	1 - LOW - Red	1423	1415	1407	1391	1375	1338	1300	1246	1192
*UE1D140A9601A	4 - HIGH - Black	2462	2407	2351	2284	2216	2143	2069	1989	1908
	3 - MED.-HIGH - Blue	2128	2112	2096	2054	2011	1949	1887	1797	1706
	2 - MED.-LOW - Yellow	1755	1746	1736	1719	1702	1656	1609	1564	1518
	1 - LOW - Red	1450	1446	1442	1427	1411	1383	1354	1298	1241

* May be "A" or "T"

From D330672 Rev. 17

CFM VS. TEMPERATURE RISE																				
MODEL	CFM (CUBIC FEET PER MINUTE)																			
	500	600	700	800	900	1000	1100	1200	1300	1400	1500	1600	1700	1800	1900	2000	2100	2200	2300	2400
*UE1A040A9241A	54	49	42	37	33	30														
*UE1A060A9241A			63	56	49	44														
*UE1A060A9361A				56	49	44	40	37	34	32										
*UE1B060A9361A				56	49	44	40	37	34	32										
*UE1B080A9361A						59	54	49	46	42										
*UE1B100A9361A						58	52	49	46	42	40	37	35	33						
*UE1B080A9481A							67	62	57	53	49									
*UE1C100A9481A							67	62	57	53	49	46	44	41	39	37				
*UE1C100A9601A								62	57	53	49	46	44	41	39	37	35	34	32	31
*UE1D120A9601A											59	56	52	49	47	44	42	40		
*UE1D140A9601A											69	65	61	58	55	52	49	47	45	

* May be "A" or "T"

From C340782 Sh.1 Rev. 8

Service Facts

FURNACE AIRFLOW (CFM) VS. STATIC PRESSURE (ins. w.g.)										
MODEL	SPEED TAP	0.10	0.20	0.30	0.40	0.50	0.60	0.70	0.80	0.90
*DE1A060A9361A	4 - HIGH - Black	1480	1429	1376	1318	1282	1188	1112	1029	959
	3 - MED.-HIGH - Blue	1302	1276	1229	1188	1141	1088	1024	953	882
	2 - MED.-LOW - Yellow	1115	1100	1070	1035	1000	965	918	859	790
	1 - LOW - Red	956	947	918	888	859	824	788	741	682
*DE1B060A9361A	4 - HIGH - Black	1480	1429	1376	1318	1282	1188	1112	1029	959
	3 - MED.-HIGH - Blue	1302	1276	1229	1188	1141	1088	1024	953	882
	2 - MED.-LOW - Yellow	1115	1100	1070	1035	1000	965	918	859	790
	1 - LOW - Red	956	947	918	888	859	824	788	741	682
*DE1B080A9451A	4 - HIGH - Black	1798	1750	1692	1642	1575	1500	1425	1325	1225
	3 - MED.-HIGH - Blue	1384	1367	1333	1300	1275	1233	1192	1142	1083
	2 - MED.-LOW - Yellow	1210	1150	1108	1075	1042	1008	967	925	867
	1 - LOW - Red	1005	970	808	775	767	733	700	675	617
*DE1B100A9451A	4 - HIGH - Black	1767	1731	1669	1615	1546	1469	1392	1300	1146
	3 - MED.-HIGH - Blue	1382	1354	1323	1292	1254	1207	1177	1108	1038
	2 - MED.-LOW - Yellow	1130	1138	1115	1085	1054	1015	977	938	877
	1 - LOW - Red	840	831	815	792	762	731	700	654	625
*DE1C100A9601A	4 - HIGH - Black	2165	2113	2060	1995	1929	1842	1755	1674	1593
	3 - MED.-HIGH - Blue	1962	1927	1891	1839	1786	1724	1662	1581	1500
	2 - MED.-LOW - Yellow	1705	1688	1671	1636	1600	1547	1492	1435	1377
	1 - LOW - Red	1492	1467	1442	1414	1385	1346	1307	1243	1179
*DE1D120A9601A	4 - HIGH - Black	2241	2202	2163	2106	2049	1979	1908	1804	1700
	3 - MED.-HIGH - Blue	1981	1962	1942	1904	1866	1805	1743	1680	1617
	2 - MED.-LOW - Yellow	1721	1705	1688	1671	1653	1611	1569	1515	1461
	1 - LOW - Red	1476	1466	1456	1440	1423	1392	1361	1302	1243

From D341548 Rev. 1

CFM VS. TEMPERATURE RISE																					
MODEL	CFM (CUBIC FEET PER MINUTE)																				
	500	600	700	800	900	1000	1100	1200	1300	1400	1500	1600	1700	1800	1900	2000	2100	2200	2300	2400	
*DE1A060A9361A				56	49	44	40	37	34	32											
*DE1B060A9361A				56	49	44	40	37	34	32											
*DE1B080A9451A					64	57	52	48	44	41											
*DE1B100A9451A								62	57	53	49	46	44	41							
*DE1C100A9601A									62	57	53	49	46	44	41	39	37	35	34	32	31
*DE1D120A9601A												59	56	52	49	47	44	42	40		

From C330671 Sh. 3 Rev. 10

AIRFLOW ADJUSTMENT

Check inlet and outlet air temperatures to make sure they are within the ranges specified on the furnace rating nameplate. If the airflow needs to be increased or decreased, see the wiring diagram for information on changing the speed of the blower motor.

⚠ WARNING

Disconnect power to the unit before removing the blower door. Failure to follow this warning could result in personal injury from moving parts.

This unit is equipped with a blower door switch which cuts power to the blower and gas valve causing shutdown when the door is removed. Operation with the door removed or ajar can permit the escape of dangerous fumes. All panels must be securely closed at all times for safe operation of the furnace.

INDOOR BLOWER TIMING

Heating: The control module controls the indoor blower. The blower start is fixed at 45 seconds after ignition. The FAN-OFF period is field selectable by dip switches at 60, 100, 140, or 180 seconds. The factory setting is 100 seconds (See wiring diagram).

Cooling: The fan delay off period is factory set at 0 seconds. The option for 80 second delay off is field selectable (See wiring diagram).

NOTE:

Direct drive motors have bearings which are permanently lubricated and under normal use, lubrication is not recommended.

Service Facts

INTEGRATED FURNACE CONTROL ERROR FLASH CODES	
Flashing Slow ---	Normal - No call for Heat
Flashing Fast ---	Normal - Call for Heat
Continuous ON ---	Replace IFC
Continuous OFF ---	Check Power
2 Flashes ---	System Lockout (Retries or Recycles exceeded)
3 Flashes ---	Draft Pressure Error - Possible problems:
4 Flashes ---	Open Temperature Limit Circuit
5 Flashes ---	Flame sensed when no flame should be present
6 Flashes ---	115 volt AC power reversed, poor grounding or system voltage too low
7 Flashes ---	Gas valve circuit error
8 Flashes ---	Low flame sense signal

ABNORMAL CONDITIONS

- EXCESSIVE COMBUSTION VENT PRESSURE OR FLUE BLOCKAGE**
 If pressure against the induced draft blower outlet becomes excessive, the pressure switch will shut off the gas valve until acceptable combustion pressure is again available.
- LOSS OF FLAME OR GAS SUPPLY FAILURE**
 If loss of flame occurs during a heating cycle (when flame is not present at the sensor), the control module will retry the ignition sequence up to two times after the sensor cools. If ignition is not achieved, it will lockout the furnace.
- POWER FAILURE**
 If there is a power failure during a heating cycle, the system will restart the ignition sequence automatically when power is restored, if the thermostat still calls for heat.
- INDUCED DRAFT BLOWER FAILURE**
 If pressure is not sensed by the pressure switch, it will not allow the gas valve to open, therefore the unit will not start. If failure occurs during a running cycle, the pressure switch will cause the gas valve to close and shut the unit down.

The following warning complies with State of California law, Proposition 65.

WARNING

This product contains fiberglass wool insulation!
Fiberglass dust and ceramic fibers are believed by the State of California to cause cancer through inhalation. Glasswool fibers may also cause respiratory, skin, or eye irritation.

PRECAUTIONARY MEASURES

- Avoid breathing fiberglass dust.
- Use a NIOSH approved dust/mist respirator.
- Avoid contact with the skin or eyes. Wear long-sleeved, loose-fitting clothing, gloves, and eye protection.
- Wash clothes separately from other clothing: rinse washer thoroughly.
- Operations such as sawing, blowing, tear-out, and spraying may generate fiber concentrations requiring additional respiratory protection. Use the appropriate NIOSH approved respirator in these situations.

FIRST AID MEASURES

- Eye Contact** – Flush eyes with water to remove dust. If symptoms persist, seek medical attention.
- Skin Contact** – Wash affected areas gently with soap and warm water after handling.



American Standard Inc.
 6200 Troup Highway
 Tyler, TX 75707

For more information contact
 your local dealer (distributor)

Since the manufacturer has a policy of continuous product and product data improvement, it reserves the right to change design and specifications without notice.