

Service Facts



X342649P01

Upflow/ Horizontal Left and Downflow/ Horizontal Right, Gas-Fired, Direct/Non-Direct Vent, Variable Speed, 3-Stage Condensing Communicating Only Furnaces

***UH3-SF-1A**

***UH3B060ACV3VA**
***UH3B080ACV3VA**
***UH3C100ACV4VA**
***UH3D120ACV5VA**

***DH3B060ACV3VA**
***DH3B080ACV3VA**
***DH3C100ACV4VA**
***DH3D120ACV5VA**

* First letter may be "A" or "T"

This communicating furnace works ONLY with the *CONT900AC43UA programmable comfort control. (* may be "A" or "T")

B - FURNACES

IMPORTANT — This document contains a wiring diagram and service information. This is customer property and is to remain with this unit. Please return to service information pack upon completion of work.

⚠ WARNING DISCONNECT POWER BEFORE SERVICING

PRODUCT SPECIFICATIONS ①

MODEL	*UH3B060ACV3VA	*UH3B080ACV3VA	*UH3C100ACV4VA	*UH3D120ACV5VA
TYPE	Upflow/ Horizontal	Upflow/ Horizontal	Upflow/ Horizontal	Upflow/ Horizontal
RATINGS ②				
1st Stage Input BTUH	24,000	32,000	40,000	48,000
1st Stage Capacity BTUH (ICS) ③	22,000	30,000	38,000	46,000
2nd Stage Input BTUH	41,000	54,000	68,000	82,000
3rd Stage Input BTUH	60,000	80,000	100,000	120,000
3rd Stage Capacity BTUH (ICS) ③	55,000	73,000	92,000	112,000
Temp. rise (Min.-Max.) °F.	35 - 65	35 - 65	35 - 65	40 - 70
AFUE	93.0	95.0	95.0	92.1
BLOWER DRIVE	DIRECT	DIRECT	DIRECT	DIRECT
Diameter - Width (In.)	10 x 8	10 x 8	10 x 10	10 x 10
No. Used	1	1	1	1
Speeds (No.)	Variable	Variable	Variable	Variable
CFM vs. in. w.g.	See Fan Performance Table	See Fan Performance Table	See Fan Performance Table	See Fan Performance Table
Motor HP	1/2	1/2	1	1
RP.M.	Variable	Variable	Variable	Variable
Volts / Ph / Hz	115/1/60	115/1/60	115/1/60	115/1/60
COMBUSTION FAN - Type	Centrifugal	Centrifugal	Centrifugal	Centrifugal
Drive - No. Speeds	Direct - Variable	Direct - Variable	Direct - Variable	Direct - Variable
Motor HP - RPM	1/50 - 5000	1/50 - 5000	1/50 - 5000	1/50 - 5000
Volts / Ph / Hz	33 - 110/3/60 - 180	33 - 110/3/60 - 180	33 - 110/3/60 - 180	33 - 110/3/60 - 180
FLA	1.0	1.0	1.0	1.0
FILTER — Furnished?	Yes	Yes	Yes	Yes
Type Recommended	High Velocity	High Velocity	High Velocity	High Velocity
Hi Vel. (No.-Size-Thk.)	1 - 17x25 - 1 in.	1 - 17x25 - 1 in.	1 - 20x25 - 1 in.	1 - 24x25 - 1 in.
VENT — Size (in.)	2 Round	2 Round	3 Round	3 Round
HEAT EXCHANGER				
Type - Fired	Aluminized Steel - Type I	Aluminized Steel - Type I	Aluminized Steel - Type I	Aluminized Steel - Type I
-Unfired				
Gauge (Fired)	20	20	20	20
ORIFICES — Main				
Nat. Gas Qty. — Drill Size	3 — 45	4 — 45	5 — 45	6 — 45
LP. Gas Qty. — Drill Size ⑤	3 — 51	4 — 51	5 — 51	6 — 51
GAS VALVE	Redundant - Three Stage	Redundant - Three Stage	Redundant - Three Stage	Redundant - Three Stage
PILOT SAFETY DEVICE				
Type	Hot Surface Igniter	Hot Surface Igniter	Hot Surface Igniter	Hot Surface Igniter
BURNERS — Type	Multiport Inshot	Multiport Inshot	Multiport Inshot	Multiport Inshot
Number	3	4	5	6
POWER CONN. — V / Ph / Hz ④	115/1/60	115/1/60	115/1/60	115/1/60
Ampacity (In Amps)	11.1	11.1	13.5	15.2
Max. Overcurrent Protection (Amps)	15	15	20	20
PIPE CONN. SIZE (IN.)	1/2	1/2	1/2	1/2
DIMENSIONS				
Crated (In.)	H x W x D 41-3/4 x 19-1/2 x 30-1/2	H x W x D 41-3/4 x 19-1/2 x 30-1/2	H x W x D 41-3/4 x 23 x 30-1/2	H x W x D 41-3/4 x 26-1/2 x 30-1/2
WEIGHT				
Shipping (Lbs.) / Net (Lbs)	158 / 146	168 / 156	197 / 185	206 / 193

① Central Furnace heating designs are certified by AGA and CSA.

② For U.S. applications, above input ratings (BTUH) are up to 2,000 feet, derate 4% per 1,000 feet for elevations above 2,000 feet above sea level.

For Canadian applications, above input ratings (BTUH) are up to 4,500 feet, derate 4% per 1,000 feet for elevations above 4,500 feet above sea level.

③ Based on U.S. government standard tests.

④ The above wiring specifications are in accordance with National Electrical Code; however, installations must comply with local codes.

⑤ Furnace ships in natural gas configuration. The LP conversion kit used with the 3 stage furnace is BAYLPSS220A or BAYLPKT220A.

Service Facts

PRODUCT SPECIFICATIONS ①

MODEL	*DH3B060ACV3VA	*DH3C080ACV3VA	*DH3C100ACV4VA	*DH3D120ACV5VA
TYPE	Downflow / Horizontal	Downflow / Horizontal	Downflow / Horizontal	Downflow / Horizontal
RATINGS ②				
1st Stage Input BTUH	24,000	32,000	40,000	48,000
1st Stage Capacity BTUH (ICS) ③	22,000	30,000	38,000	46,000
2nd Stage Input BTUH	41,000	54,000	68,000	82,000
3rd Stage Input BTUH	60,000	80,000	100,000	120,000
3rd Stage Capacity BTUH (ICS) ③	55,000	73,000	92,000	112,000
Temp. rise (Min.-Max.) °F.	35 - 65	35 - 65	35 - 65	40 - 70
AFUE	92.1	95.0	95.0	92.1
BLOWER DRIVE				
	DIRECT	DIRECT	DIRECT	DIRECT
Diameter - Width (In.)	10 x 8	10 x 8	10 x 10	10 x 10
No. Used	1	1	1	1
Speeds (No.)	Variable	Variable	Variable	Variable
CFM vs. in. w.g.	See Fan Performance Table	See Fan Performance Table	See Fan Performance Table	See Fan Performance Table
Motor HP	1/2	1/2	3/4	1
R.P.M.	Variable	Variable	Variable	Variable
Volts / Ph / Hz	115/1/60	115/1/60	115/1/60	115/1/60
COMBUSTION FAN - Type				
	Centrifugal	Centrifugal	Centrifugal	Centrifugal
Drive - No. Speeds	Direct - Variable	Direct - Variable	Direct - Variable	Direct - Variable
Motor HP - RPM	1/50 - 5000	1/50 - 5000	1/50 - 5000	1/50 - 5000
Volts / Ph / Hz	33 - 110/3/60 - 180	33 - 110/3/60 - 180	33 - 110/3/60 - 180	33 - 110/3/60 - 180
FLA	1.0	1.0	1.0	1.0
FILTER — Furnished?				
	Yes	Yes	Yes	Yes
Type Recommended	High Velocity	High Velocity	High Velocity	High Velocity
Hi Vel. (No.-Size-Thk.)	2 - 14x20 - 1 in.	2 - 14x20 - 1 in.	2 - 16x20 - 1 in.	2 - 16x20 - 1 in.
VENT — Size (in.)				
	2 Round	2 Round	3 Round	3 Round
HEAT EXCHANGER				
Type - Fired	Aluminized Steel - Type I	Aluminized Steel - Type I	Aluminized Steel - Type I	Aluminized Steel - Type I
-Unfired				
Gauge (Fired)	20	20	20	20
ORIFICES — Main				
Nat. Gas. Qty. — Drill Size	3 — 45	4 — 45	5 — 45	6 — 45
L.P. Gas Qty. — Drill Size ⑤	3 — 51	4 — 51	5 — 51	6 — 51
GAS VALVE				
	Redundant - Three Stage	Redundant - Three Stage	Redundant - Three Stage	Redundant - Three Stage
PILOT SAFETY DEVICE				
Type	Hot Surface Igniter	Hot Surface Igniter	Hot Surface Igniter	Hot Surface Igniter
BURNERS — Type				
	Multiport Inshot	Multiport Inshot	Multiport Inshot	Multiport Inshot
Number	3	4	5	6
POWER CONN. — V / Ph / Hz ④				
	115/1/60	115/1/60	115/1/60	115/1/60
Ampacity (In Amps)	11.1	11.1	13.5	15.2
Max. Overcurrent Protection (Amps)	15	15	20	20
PIPE CONN. SIZE (IN.)				
	1/2	1/2	1/2	1/2
DIMENSIONS				
	H x W x D	H x W x D	H x W x D	H x W x D
Crated (In.)	41-3/4 x 19-1/2 x 30-1/2	41-3/4 x 19-1/2 x 30-1/2	41-3/4 x 23 x 30-1/2	41-3/4 x 26-1/2 x 30-1/2
WEIGHT				
Shipping (Lbs.) / Net (Lbs)	160 / 146	168 / 158	185 / 175	206 / 196

① Central Furnace heating designs are certified by AGA and CSA.

② For U.S. applications, above input ratings (BTUH) are up to 2,000 feet, derate 4% per 1,000 feet for elevations above 2,000 feet above sea level.
For Canadian applications, above input ratings (BTUH) are up to 4,500 feet, derate 4% per 1,000 feet for elevations above 4,500 feet above sea level.

③ Based on U.S. government standard tests.

④ The above wiring specifications are in accordance with National Electrical Code; however, installations must comply with local codes.

⑤ Furnace ships in natural gas configuration. The LP conversions kit used with the 3 stage furnace is BAYLPSS220A or BAYLPKT220A.

SAFETY SECTION

WARNING

CARBON MONOXIDE POISONING HAZARD

Failure to follow the steps outlined below for each appliance connected to the venting system being placed into operation could result in carbon monoxide poisoning or death.

The following steps shall be followed for each appliance connected to the venting system being placed into operation, while all other appliances connected to the venting system are not in operation:

1. Seal any unused openings in the venting system.
2. Inspect the venting system for proper size and horizontal pitch, as required in the National Fuel Gas Code, ANSI Z223.1/NFPA 54 or the CAN/CGA B149 Installation Codes and these instructions. Determine that there is no blockage or restriction, leakage, corrosion and other deficiencies which could cause an unsafe condition.
3. As far as practical, close all building doors and windows and all doors between the space in which the appliance(s) connected to the venting system are located and other deficiencies which could cause an unsafe condition.
4. Close fireplace dampers.
5. Turn on clothes dryers and any appliance not connected to the venting system. Turn on any exhaust fans, such as range hoods and bathroom exhausts, so they are operating at maximum speed. Do not operate a summer exhaust fan.
6. Follow the lighting instructions. Place the appliance being inspected into operation. Adjust the thermostat so appliance is operating continuously.
7. If improper venting is observed during any of the above tests, the venting system must be corrected in accordance with the National Fuel Gas Code, ANSI Z221.1/NFPA 54 and/or CAN/CGA B149 Installation Codes.
8. After it has been determined that each appliance connected to the venting system properly vents where tested as outlined above, return doors, windows, exhaust fans, fireplace dampers and any other gas-fired burning appliance to their previous conditions of use.

WARNING

The cabinet must have an uninterrupted or unbroken ground according to National Electrical Code, ANSI/NFPA 70 - "latest edition" and Canadian Electrical Code, CSA C22.1 or local codes to minimize personal injury if an electrical fault should occur.

Failure to follow this warning could result in an electrical shock, fire, injury, or death.

WARNING

CARBON MONOXIDE POISONING HAZARD

Failure to follow the installation instructions for the venting system being placed into operation could result in carbon monoxide poisoning or death.

WARNING

FIRE OR EXPLOSION HAZARD

Failure to follow the safety warnings exactly could result in serious injury, death or property damage. Never test for gas leaks with an open flame. Use a commercially available soap solution made specifically for the detection of leaks to check all connections. A fire or explosion may result causing property damage, personal injury, or loss of life.

WARNING

FIRE OR EXPLOSION HAZARD

Failure to follow the safety warnings exactly could result in serious injury, death or property damage. Improper servicing could result in dangerous operation, serious injury, death, or property damage.

WARNING

BODILY INJURY CAN RESULT FROM HIGH VOLTAGE ELECTRICAL COMPONENTS, FAST MOVING FANS, AND COMBUSTIBLE GAS. FOR PROTECTION FROM THESE INHERENT HAZARDS DURING INSTALLATION AND SERVICING, THE ELECTRICAL SUPPLY MUST BE DISCONNECTED AND THE MAIN GAS VALVE MUST BE TURNED OFF. IF OPERATING CHECKS MUST BE PERFORMED WITH THE UNIT OPERATING, IT IS THE TECHNICIAN'S RESPONSIBILITY TO RECOGNIZE THESE HAZARDS AND PROCEED SAFELY.

WARNING

Should overheating occur, or the gas supply fail to shut off, shut off the Gas Valve to the unit before shutting off the electrical supply. Failure to follow this warning could result in property damage, personal injury, or death.

CAUTION

The integrated furnace control is polarity sensitive. The hot leg of the 115 VAC power must be connected to the BLACK field lead

NOTE:

CONTINUOUS fan mode during COOLING operation may not be appropriate in humid climates. If the indoor air exceeds 60% relative humidity or simply feels uncomfortably humid, it is recommended that the fan only be used in the AUTO mode.

Service Facts

FURNACE COMPONENTS

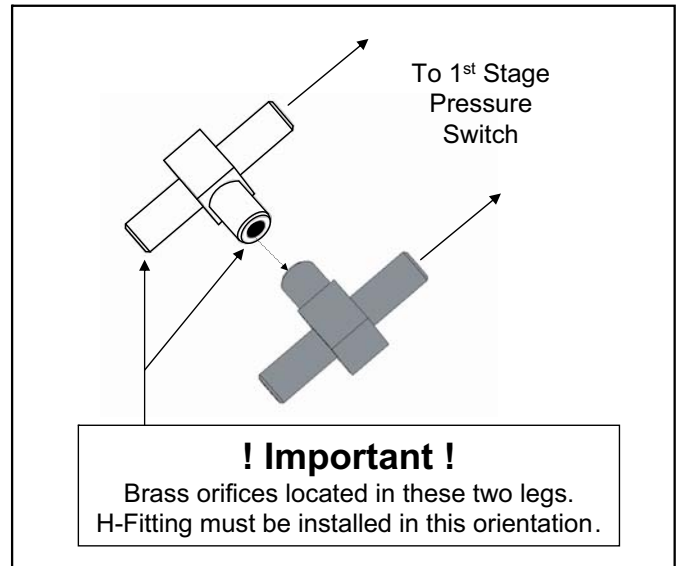
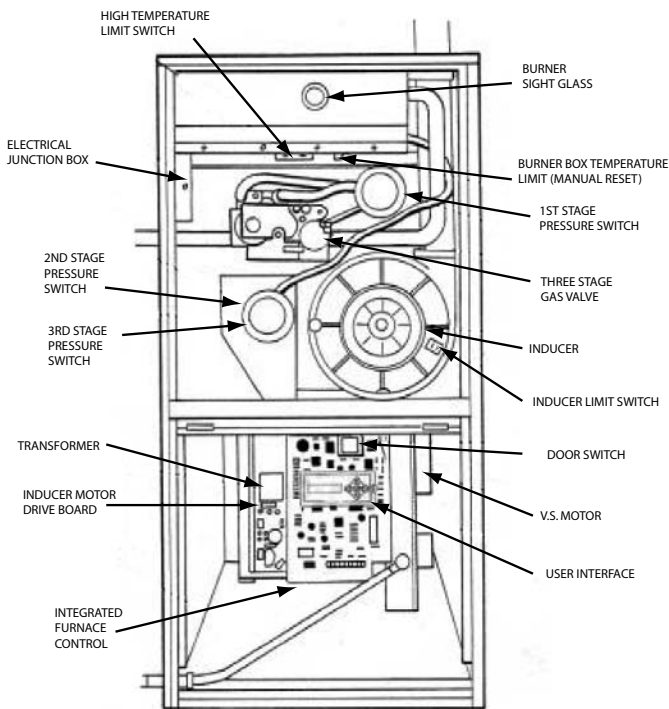

VACUUM HOSE ROUTING

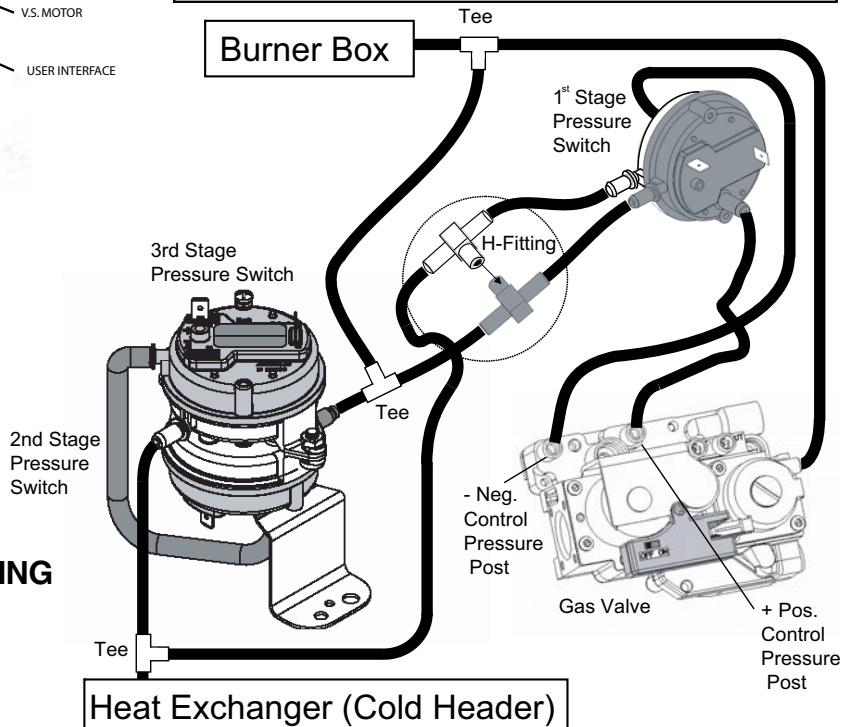

USER INTERFACE DISPLAY

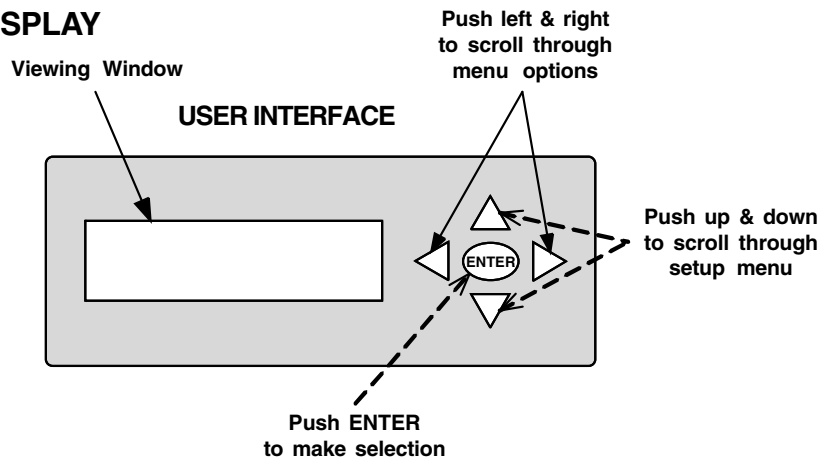

User Interface pictured above adjusts variable speed airflow options and other unit settings

USER INTERFACE MENU

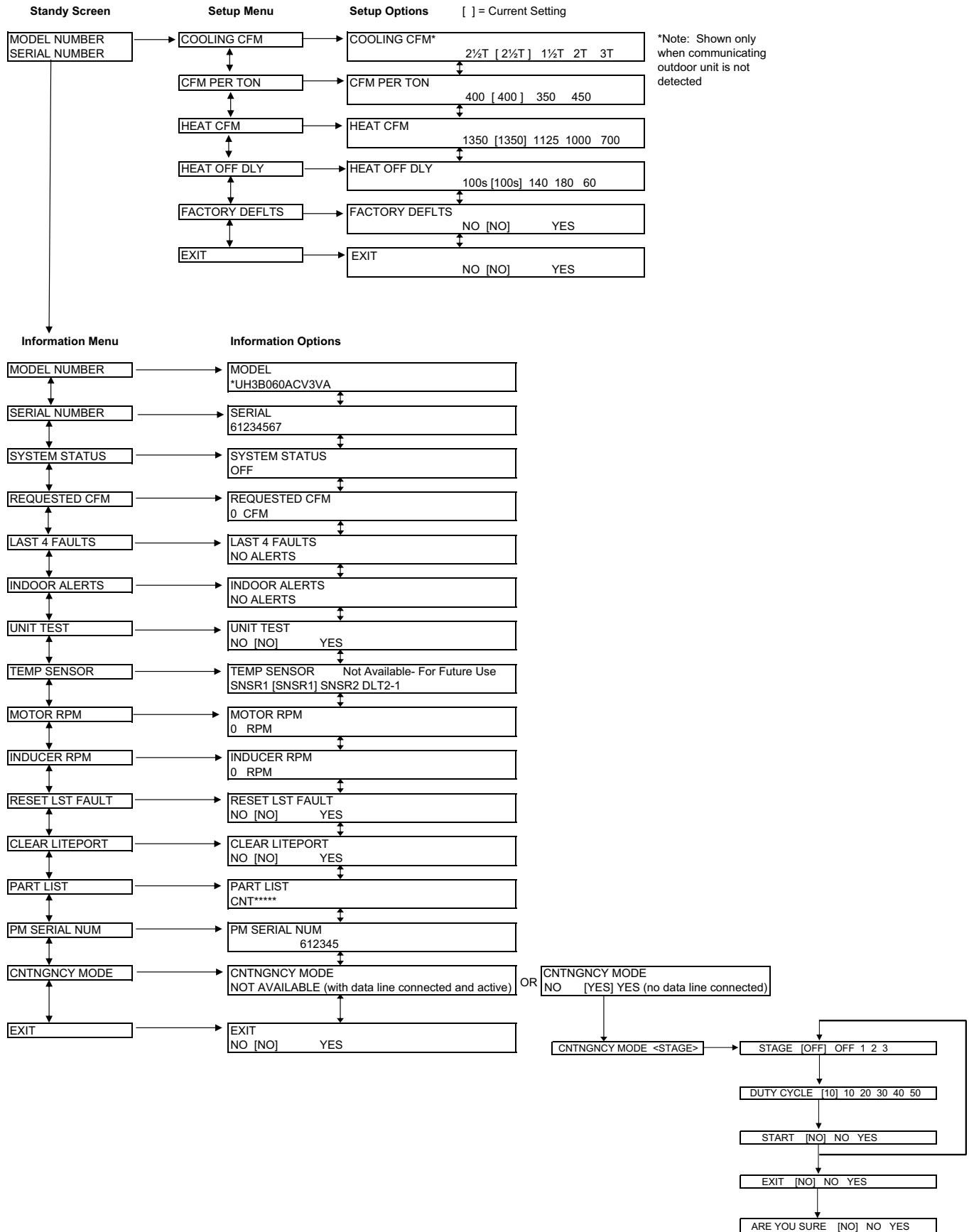

Service Facts

Service procedure to access User Interface for 3-Stage Furnace

This procedure must only be performed by trained service personnel.

WARNING

ELECTRICAL SHOCK HAZARD
DO NOT BYPASS THE DOOR SWITCH BY ANY PERMANENT MEANS.
FAILURE TO FOLLOW WARNING COULD RESULT IN SERIOUS PERSONAL INJURY OR DEATH.

WARNING

ELECTRICAL SHOCK HAZARD
DO NOT TOUCH ANY COMPONENTS OTHER THAN THE DISPLAY ASSEMBLY AND THE DOOR SWITCH DURING THIS PROCEDURE.
FAILURE TO FOLLOW WARNING COULD RESULT IN SERIOUS PERSONAL INJURY OR DEATH.

1. Remove Blower Door panel by turning the two door latches $\frac{1}{4}$ turn.
2. Lower door panel and remove from service access area.
3. Using one hand, depress the door switch (there must be power to the control system for the Display Assembly to function) and keep the door switch depressed during programming.
4. Using the other hand move through the Display Assembly menu using the arrow buttons.
5. The User Interface menu on pages 5 and 6 is a guide to the menu options.
6. When programming is complete release door switch and replace the Blower Door.

Diagram 1

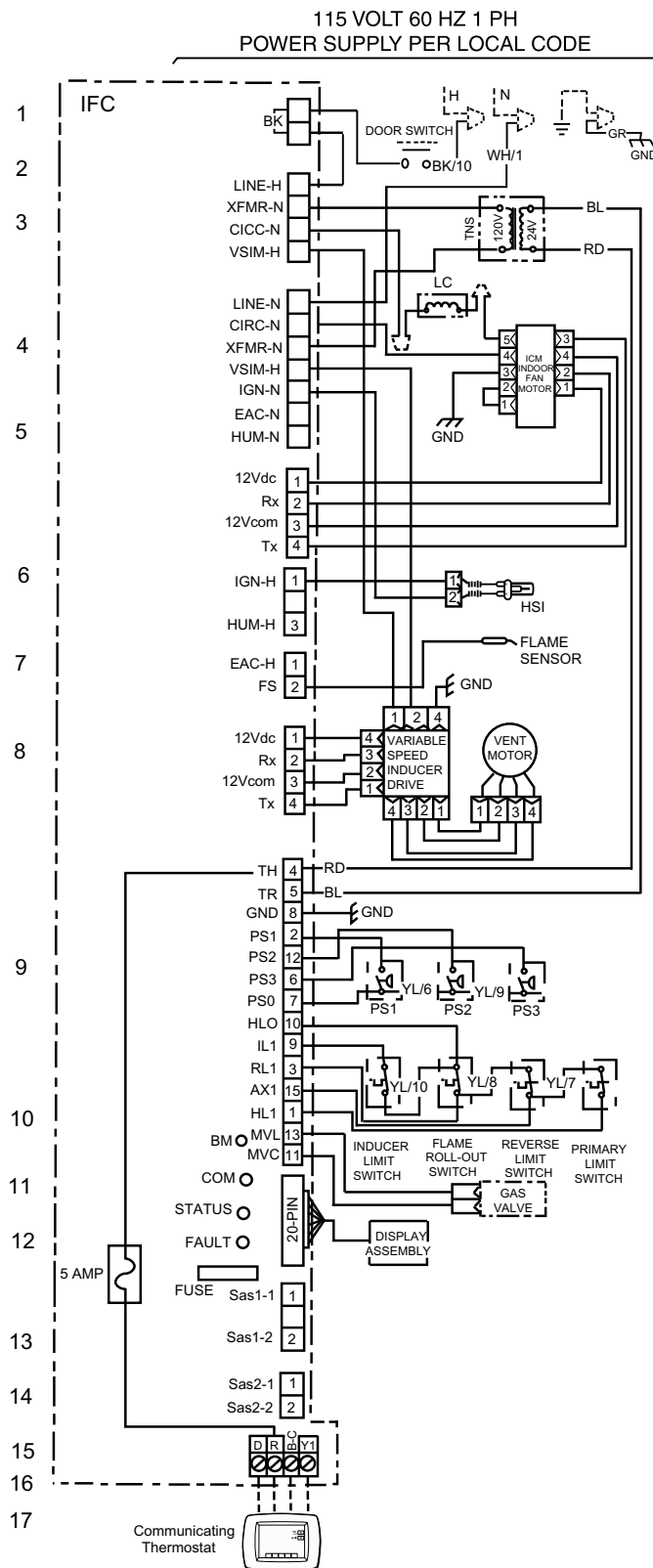

SEQUENCE OF OPERATION

NOTE:

The numbers in parentheses refer to the numbers along the left side of the diagram 1.

- The communicating comfort control (17) signals the furnace IFC for first stage heat. (16)
- The IFC then checks all safeties, thermostats (10) & pressure switches PS-1, 2 & 3. (9)
- The IFC signals the variable speed inducer drive (8) to start the vent motor (8) and go to its second stage speed.

NOTE:

The furnace lights in Second Stage mode.

- First & second stage pressure switches PS-1 & 2 close. (9)
- The IFC receives a 24 Volt AC signal from pressure switches PS-1 & PS-2 when they close. (9) This verifies the vent motor is moving the correct amount of combustion air through the furnace and vent system.
- IFC starts the hot surface igniter learning routine warm up time cycle. (6)
- IFC turns on the gas valve. (11) Trial time for ignition is five seconds.
- The IFC verifies ignition by the flame current sensing method. (7) If a flame is not detected, the IFC will cycle the furnace three times to try and verify a flame. If no flame is detected, the IFC will lock out for one hour. The IFC will send an alert code to the communicating comfort control and user interface. The IFC will also flash its Red alert LED two times repeatedly.
- If a flame is detected, the IFC will start the heat exchanger warm-up time delay for the indoor blower.
- After 45 seconds, the IFC signals the indoor blower (4) to engage and run at its second stage heat speed.
- The IFC then signals the variable speed inducer motor drive board (8) to ramp down the vent motor in steps to the first stage vent motor speed. The reduction of the vent motor speed in steps allows the gas flow through the gas valve to also be reduced in steps.
- When the IFC no longer detects the 24 Volt AC signal from pressure switch # 2, PS-2, (9) it will signal the indoor blower (4) to go to its first stage heating speed.
- The communicating comfort control (16) will continue to call for first stage heat operation until the indoor temperature is back at the communicating comfort control set point OR,

Service Facts

- If the communicating comfort control (17) does not detect that the indoor temperature is moving back towards its set point or the indoor temperature is still moving away from the communicating comfort control set point, it will signal the IFC (16) to go to second stage heat.
- The IFC (8) signals the variable speed inducer drive (8) to ramp the vent motor up in steps to its learned second stage RPM speed.
- As the vent motor (8) speed increases the amount of gas coming through the gas valve will increase.
- When the IFC detects a 24 Volt AC signal that pressure switch #2, PS-2, (9) is closed, the IFC will then signal the indoor blower (4) to go to its second stage heat speed.
- The communicating comfort control (17) will continue to call for second stage heat operation until the indoor temperature approaches its set point. Before the indoor temperature reaches the communicating comfort control (17) set point the communicating comfort control will signal the furnace IFC to go back to first stage operation OR,
- If the communicating comfort control (17) senses the indoor temperature is not moving back towards its set point or the indoor temperature is still moving away from the communicating comfort control set point, it will signal the furnace IFC to go to third stage heat.
- The IFC signals the variable speed inducer drive board (8) to ramp the vent motor in steps to its learned third stage RPM speed.
- As the vent motor speed increases the amount of gas coming through the gas valve will increase.
- When the IFC detects a 24 Volt AC Signal from Pressure Switch #3, PS-3, (9) closing, the IFC will then signal the indoor blower (4) to go to its third stage heat speed.
- The communicating comfort control will continue to monitor the indoor temperature and send signals to the IFC to operate at different stages or turn off so that it can maintain the indoor temperature at the homeowner's set point.

PERSONALITY MODULE

The Personality Module is a removable memory device, on which is stored model specific data required for proper Furnace operation. The Personality Module is tethered to the unit and must remain with the Furnace at all times. The Personality module must remain plugged into the furnace IFC.

UNIT TEST MODE

A qualified technician can cycle the Variable Speed Indoor Blower and the Three Stage Gas Furnace through its Three Stages of Heat at the User Interface.

- To facilitate unit testing in the field, a Unit Test option is available via the User Interface. See User Interface Menu on page 5 and 6.
- When the Unit Test option is activated, the unit will start the indoor blower. The indoor blower will run for 10 seconds and then turn off.
- Next, the unit will begin a normal ignition sequence. After normal ignition, the Furnace will immediately operate in Second Stage with circulator energized for 10 seconds. The control will transition to Third Stage operation for 10 seconds. The control will then transition to First Stage operation for 10 seconds. Finally, the control will then transition to off, running the normal post-purge and the normal heat off delay.
- All safety functions will be operable during the Unit Test function. Certain Alert conditions will cause termination of the Unit Test sequence and the control will respond as required.
- If a button on the User Interface is pressed during the Unit Test Mode, the test will be terminated.
- If a heat demand is received from the communicating comfort control during the unit test the control will exit the unit test mode, and run at the comfort control demand.
- If the control receives any other communicating comfort control demand (example- a call for cooling) the control will complete the unit test before responding to the communicating comfort control demand.

UNIT TEST CYCLE

- The unit test cycle is entered at the user interface.
- The test cycle can only be entered when the comfort control has **no demand** and the furnace IFC is **not reporting a fault**. Disconnect the data wire D from the furnace IFC terminal block to ensure the unit test cycle will not be interrupted.
- Scroll down using the **▼ button** at the user interface until the display reads:
- **UNIT TEST**. Press the **Enter** button.
- **UNIT TEST** and **◀ NO (NO) ▶** will now be displayed. Use the **◀** or **▶** arrow button to change the **NO** to a **YES** and then press **ENTER**.
- **ARE YOU SURE** and **NO (NO)** will now be displayed. Use the **◀** or **▶** arrow button to change the **NO** to a **YES** and then press **ENTER**.

- **UNIT TEST** and **Stage OFF** will now be displayed. The variable speed indoor blower will then be turned on by the IFC for 10 seconds and then off.
 - **UNIT TEST** and **Stage 2** will now be displayed. The Furnace IFC will now go to second stage heat. Forty-five seconds after flame is detected, the furnace will call for the variable speed indoor blower.
 - **UNIT TEST** and **Stage 3** will now be displayed. The furnace IFC will ramp up the variable speed inducer motor and the indoor variable speed blower to third stage operation for a few seconds.
 - **UNIT TEST** and **Stage 1** will now be displayed. The furnace IFC will ramp down the variable speed inducer motor and the indoor variable speed blower to first stage operation for a few seconds.
 - The **Model** and **Serial Number** will be displayed.
 - The variable speed indoor blower will now operate for the heat exchanger cool down cycle and then shut off at the end of the cycle.
 - Reconnect the data wire to the D terminal of the furnace IFC.
- (6) To enter the contingency mode of operation, turn 115 VAC power off. When the Green LED on the variable speed inducer drive goes out, turn 115 VAC power back on.
 - (7) Scroll down using the down arrow ▼ at the User Interface until you see **CNTNGNCY Mode**, then press the **Enter** button.
 - (8) **CNTNGNCY MODE** and ◀ **STAGE** ▶ will now be displayed. Press the **Enter** button.
 - (9) **STAGE** and ◀ **OFF [OFF]** will now be displayed. A First, Second or Third Stage of heat **must** be selected. Use the ◀ or ▶ arrows to select the stage of heat wanted and then push the **Enter** button and then the ▼ button.
- **DUTY CYCLE** and **10% [10%]** will now be displayed. A duty cycle **must** now be selected from 10 to 50%. A 10% duty cycle will run the furnace for 2 minutes and then off for 18 minutes. A 50% duty cycle will run the furnace for 10 minutes and then be off for 10 minutes. These duty cycles will be repeated 3 times per hour. Use the ◀ or ▶ arrows to select a duty cycle and then push the **Enter** button and then the ▼ button.
 - **Start** and **NO [NO]** will now be displayed. With a **NO/NO** question being asked, use the ◀ or ▶ arrows to select the **YES** and then press the **ENTER** button.
 - **Are you Sure** and **NO [NO]** will now be displayed. With a **NO/ NO** question being asked, use the ◀ or ▶ arrows to select the **YES** and then press the **ENTER** button.
 - Turn 115 VAC power off. When the Green LED on the variable speed inducer drive goes out, turn 115 VAC power back on.
 - When the furnace is operating in the contingency mode (stand alone operating cycle), the user interface will display the following information. The top line will say **CNTNGNCY MODE**. The bottom line will show the operating stage number **STG (1, 2, or 3)** selected, and the percent number **10-50 %** selected.
 - All furnace operating safety comfort controls, pressure switches and communications between the IFC and the variable speed inducer drive and the variable speed indoor blower will be monitored for proper safe operation of the furnace.
 - The ◀ ▶ ▲ ▼ and **ENTER** buttons do not function in the contingency mode of operation.
 - To exit the contingency mode of operation turn off the 115 VAC power to the furnace.

STAND ALONE OPERATION (CONTINGENCY MODE)

The Contingency Mode allows the installer to set the equipment to operate in an ON/ OFF Duty Cycle mode. This mode will be activated using the User Interface. The user will select the desired level of capacity required, Stage 1, 2 or 3. The user will select the desired ON/ OFF Duty Cycle, 10% minimum to 50% maximum, (10% increments, 10% = 2 minutes On, 18 minutes Off; 50% = 10 minutes on, 10 minutes off).

CONTINGENCY MODE

Note: If a communicating comfort control is detected to be present and the contingency mode menu is selected, "NOT AVAILABLE" will be displayed on the user interface.

- (1) Stand alone operation can only be entered at the user interface.
- (2) Stand alone operation can be set up to operate the furnace in **Heating Only**.
- (3) The contingency mode is used when the communicating comfort Control is not communicating with the furnace or when setting gas pressures.
- (4) Before attempting to enter contingency mode, disconnect the Data wire D from the Furnace IFC terminal block.
- (5) The contingency mode will function only when the furnace IFC is not flashing a fault code at its Fault LED.

Service Facts

- The contingency mode (stand alone operation) will stop for any of the following reasons;
 - (1) If the furnace IFC receives a signal from the communicating comfort control. This will only happen if the data wire D from the comfort control has been reconnected to the furnace IFC terminal board terminal D.
 - (2) Power is removed from the furnace and then turned back on.
 - (3) The Furnace IFC enters a **RESET** mode of operation.
 - (4) A fault is detected by the furnace IFC. Fault LED will be flashing an Alert Code.

IFC INDUCER LEARNING ROUTINE SEQUENCE

- The furnace IFC will go through an inducer learning routine for each stage of heat.
- The learning routine is done to determine the correct amount of ventilation air for complete combustion.
- The inducer motor speed for each stage may be different for each installation due to the different length and size of the ventilation pipe, vent pipe, number of pipe fittings used, and the type of vent cap installed.
- The inducer learning routine is repeated each time the furnace IFC is powered up and the furnace IFC receives a call for heat.
- The furnace IFC will repeat the inducer motor learning routine after :
 - 150 Cycles in First Stage Heat
 - 100 Cycles in Second Stage Heat
 - 50 Cycles in third Stage Heat
- The furnace IFC checks the pressure switches PS-1 and PS-2 after a call for heat from the comfort control. They both have to be open before a heating cycle can begin.
- The furnace IFC sends a digital signal to the variable speed inducer drive to run the inducer motor at the preset factory second stage heat RPM.
- The furnace IFC waits for the PS-1 and PS-2 pressure switches to close. A 24 Volt AC signal is sent to the furnace IFC when a pressure switch closes.
- The furnace IFC will continue to signal the variable speed inducer drive to increase the inducer speed in steps if PS-1 and PS-2 are not closed when the preset factory second stage heat RPM is reached. The maximum RPM for stage two is set at 4400 RPM.
- When PS-1 and PS-2 switches close, the furnace IFC will then start the ignition cycle.
- The IFC now starts the igniter warm up cycle.
- Near the end of the warm up cycle the furnace IFC will turn on the gas valve.
- When the burner flame is detected by the furnace IFC, a 45 second time delay for indoor blower operation begins. The forty-five second time delay allows the heat exchanger and the recuperative cell to warm up. By the end of this delay time, the inducer discharge air temperature will be at its operating temperature and the density of the products of combustion will be stabilized.
- The furnace IFC now signals the variable speed indoor blower to run at the programmed second stage heating airflow.
- The furnace IFC will now start its inducer second stage heat airflow learning routine.
- The furnace IFC will signal the variable speed inducer drive beginning to reduce the inducer motor speed in steps until the furnace IFC detects that PS-2 open.
- When PS-2 opens the furnace IFC will NOTE the inducer motor RPM.
- The furnace IFC then adds an additional number of RPM to the inducer motor second stage NOTED RPM until PS-2 closes.
- The additional number of RPM plus this NOTED RPM is the learned second stage inducer operating RPM.
- The furnace IFC now stores this learned operating inducer RPM for second stage heat in its memory.
- The furnace IFC will use this stored learned operating inducer RPM for second stage heat calls it receives in the future.
- If the furnace IFC is still receiving only a call for first stage operation it will now start the learning routine for first stage.
- The furnace IFC will then continue to reduce the inducer motor RPM in steps until the furnace IFC detects that PS-1 is open.
- When PS-1 opens, the furnace IFC signals the motor drive to increase the inducer speed by an additional number of RPM. This is the learned operating speed. The furnace IFC will note this inducer motor RPM.
- The furnace IFC then adds an additional number of RPM to the first stage NOTED RPM until PS-1 closes.
- The furnace IFC now stores this learned operating inducer RPM in its memory and uses it for first stage heat calls it receives in the future.
- The IFC signals the indoor variable speed blower to operate at the programmed first stage heating airflow.
- Whenever the furnace is powered up or after a

RESET, the furnace IFC will not go through a learning routine for the third stage of heat until it receives a call for the third stage of heat.

THIRD STAGE INDUCER LEARNING ROUTINE

- When the furnace IFC receives a digital signal for the third stage of heat from the comfort control it will begin the inducer motor learning routine for third stage heat.
- The furnace will start the heating cycle in second stage, if not already on, and then begins the third stage learning routine.
- The furnace checks pressure switch three, PS-3, it must be open.
- When the furnace IFC detects that PS-3 is open, it will send a digital signal to the variable speed inducer drive to run the inducer motor at the preset factory third stage RPM.
- The furnace looks for the PS-3 pressure switch to close.
- The furnace IFC will continue to signal the variable speed inducer drive to increase the inducer motor speed in steps if PS-3 does not close when the preset factory third stage RPM is reached. The maximum RPM for the third stage heat is set at 5200 RPM.
- When the furnace IFC detects PS-3 close, it signals the variable speed indoor blower to operate at its third stage heating airflow.
- The furnace IFC enters a time delay so that the heat exchanger and the recuperative cell warm up to their third stage operating temperature. At the end of this time delay, the inducer discharge air temperature will be at its third stage operating temperature and the density of the products of combustion will stabilize.
- The furnace will now signal the variable speed inducer drive to reduce the inducer speed in steps until PS-3 opens.
- When PS-3 opens, the furnace IFC signals the motor drive to increase the inducer speed by an additional number of RPM. This is the learned operating RPM.
- The furnace IFC will now store this learned operating inducer RPM in its memory and use it for third stage heat calls it receives in the future.
- If PS-3 is not closed when the inducer reaches 5200 RPM the furnace IFC will signal the variable speed inducer drive to reduce the inducer Motor speed in steps to its second stage LEARNED SPEED. The furnace IFC flashes its Red LED three times repeatedly and also sends an Alert message to the comfort control. The furnace IFC will keep operating at second stage of heat until the comfort control sends a different signal.

INDOOR BLOWER TIMING

Heating: The Integrated Furnace Control module controls the Indoor Blower. The Blower start is fixed at 45 seconds after ignition. The FAN-OFF period is field selectable via the User Interface menu at 60, 100, 140, or 180 seconds. The factory setting is 100 seconds.

Cooling: Continuous Fan mode is 50% of the cooling CFM. This is a selectable range on the Comfort Control menu.

PERIODIC SERVICING REQUIREMENTS

WARNING

Disconnect power to the unit before removing the Blower door. Allow a minimum of 10 seconds for IFC power supply to discharge to 0 volts.

Failure to follow this warning could result in property damage, personal injury or death.

WARNING

CARBON MONOXIDE POISONING HAZARD

Failure to follow the service and/ or periodic maintenance instructions for the Furnace and venting system, could result in carbon monoxide poisoning or death.

1. GENERAL INSPECTION – *Examine the furnace installation annually for the following items:*
 - a. All flue product carrying areas external to the Furnace (i.e. chimney, vent connector) are clear and free of obstruction. A vent screen in the end of the Vent (flue) Pipe must be inspected for blockage annually.
 - b. The vent connector is in place, slopes upward and is physically sound without holes or excessive corrosion.
 - c. The return air duct connection(s) is physically sound, is sealed to the Furnace and terminates outside the space containing the Furnace.
 - d. The physical support of the Furnace should be sound without sagging, cracks, gaps, etc., around the base so as to provide a seal between the support and the base.
 - e. There are no obvious signs of deterioration of the Furnace.
2. FILTERS – Filters should be cleaned or replaced (with high velocity filters only), monthly and more frequently during high use times of the year such as midsummer or midwinter.

Service Facts

3. BLOWERS – The Blower size and speed determine the air volume delivered by the Furnace. The Blower motor bearings are factory lubricated and under normal operating conditions do not require servicing. Annual cleaning of the Blower wheel and housing is recommended for maximum air output, and this must be performed only by a qualified servicer or service agency.
4. IGNITER – This unit has a special hot surface direct ignition device that automatically lights the burners. Please note that it is very fragile and should be handled with care.

CAUTION

Do NOT touch igniter. It is extremely hot.

5. BURNER – Gas burners do not normally require scheduled servicing, however, accumulation of foreign material may cause a yellowing flame or delayed ignition. Either condition indicates that a service call is required. For best operation, burners must be cleaned annually using brushes and vacuum cleaner.

Turn off gas and electric power supply. To clean burners, remove Burner Box cover (6 to 8 screws) and top burner bracket. Lift burners from orifices.

NOTE:

Be careful NOT to break igniter when removing burners.

Clean burners with brush and/ or vacuum cleaner. Reassemble parts by reversal of the above procedure. The Burner Box must be resealed when replacing box cover.

NOTE:

On LP (propane) units, the flame may be yellow in color. Since these models use 3.5" WC Manifold Pressure, some yellow in the flames is expected and is considered normal operation of the Furnace.

Natural gas units should not have any yellow tipped flames. This condition indicates that a service call is required. For best operation, burners must be cleaned annually using brushes and vacuum cleaner.

NOTE:

On LP (propane) units, due to variations in BTU content and altitude, servicing may be required at shorter intervals.

6. HEAT EXCHANGER/ FLUE PIPE – These items must be inspected for signs of corrosion, and/ or deterioration at the beginning of each heating season by a qualified service technician and cleaned annually for best operation. To clean flue gas passages, follow recommendations below:
 - a. Turn off gas and electric power supply.

- b. Inspect flue pipe exterior for cracks, leaks, holes or leaky joints. Some discoloration of PVC pipe is normal.
 - c. Remove burner compartment door from Furnace.
 - d. Inspect around insulation covering flue collector box. Inspect induced draft Blower connections from recuperative cell and to the flue pipe connection.
 - e. Remove burners. (See 5. Burner)
 - f. Use a mirror and flashlight to inspect interior of Heat Exchanger, be careful not to damage the Igniter, Flame Sensor or other components.
 - g. If any corrosion is present, the Heat Exchanger should be cleaned by a qualified service technician.
 - h. After inspection is complete replace Burner Box cover, burners, and Furnace door.
 - i. Restore gas supply. Check for leaks using a soap solution. Restore electrical supply. Check unit for normal operation.
7. COOLING COIL CONDENSATE DRAIN - If a cooling coil is installed with the Furnace, condensate drains should be checked and cleaned periodically to assure that condensate can drain freely from coil to drain. If condensate cannot drain freely water damage could occur. (See Condensate Drain in Installer's Guide.)

*UH3 WIRING DIAGRAM

IMPORTANT:

INTEGRATED CONTROL IS POLARITY SENSITIVE. HOT LEG OF 120V POWER SUPPLY MUST BE CONNECTED TO THE BLACK POWER LEAD AS INDICATED ON WIRING DIAGRAM.

TABLE "A" MODELS	
•UH3B060ACV3V^^	•UH3C100ACV4V^^
•UX3B060ACV3V^^	•UX3C100ACV4V^^
•UH3B080ACV3V^^	•UH3D120ACV5V^^
•UX3B080ACV3V^^	•UX3D120ACV5V^^
• PREFIX MAY BE "A" OR "T" / ^^ SUFFIX MAY BE AA THROUGH ZZ	

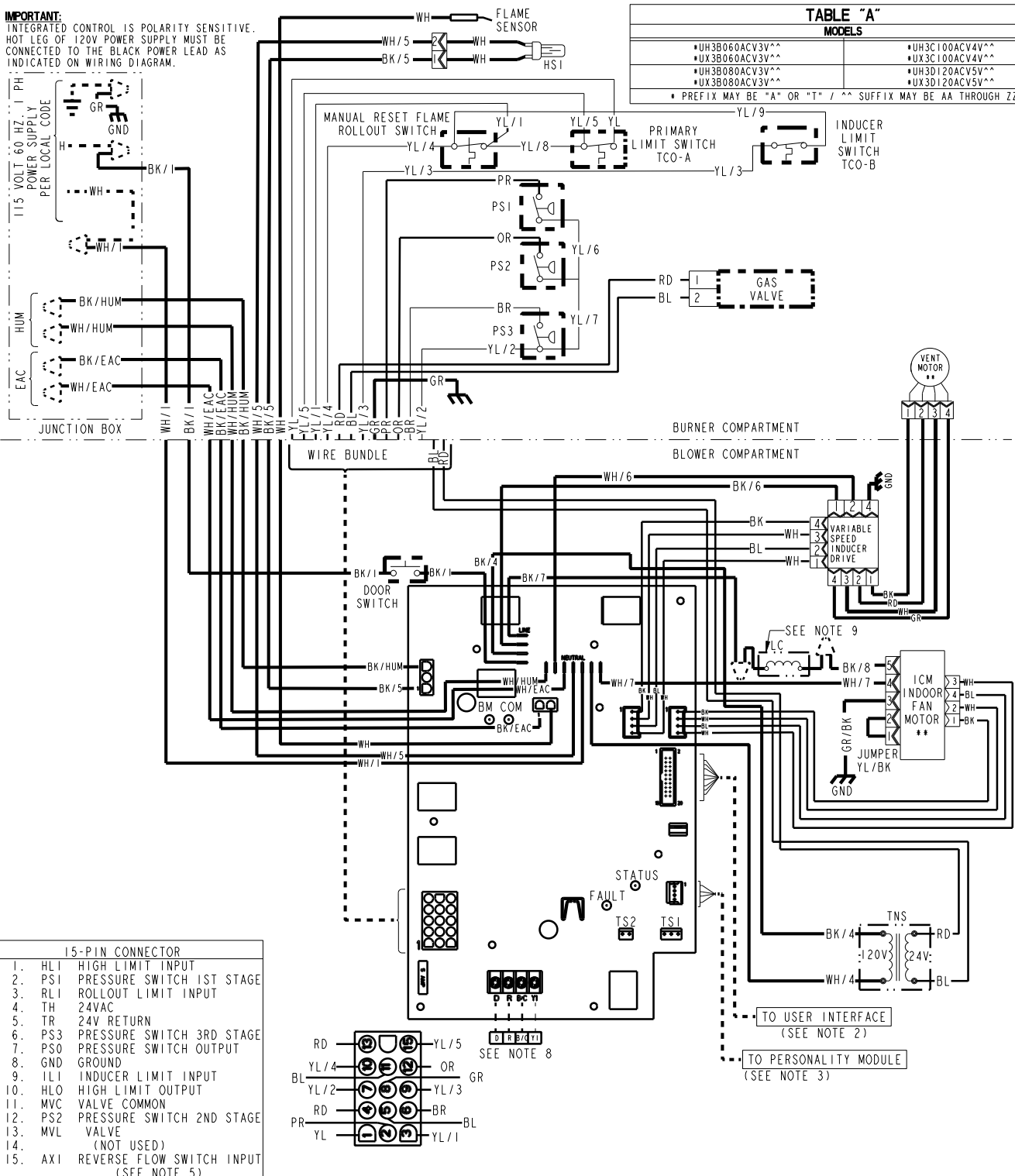

15-PIN CONNECTOR	
1.	HL1 HIGH LIMIT INPUT
2.	PS1 PRESSURE SWITCH 1ST STAGE
3.	RL1 ROLLOUT LIMIT INPUT
4.	TH 24VAC
5.	TR 24V RETURN
6.	PS3 PRESSURE SWITCH 3RD STAGE
7.	PS0 PRESSURE SWITCH OUTPUT
8.	GND GROUND
9.	IL1 INDUCER LIMIT INPUT
10.	HLO HIGH LIMIT OUTPUT
11.	MVC VALVE COMMON
12.	PS2 PRESSURE SWITCH 2ND STAGE
13.	MVL VALVE
14.	(NOT USED)
15.	AXI REVERSE FLOW SWITCH INPUT (SEE NOTE 5)

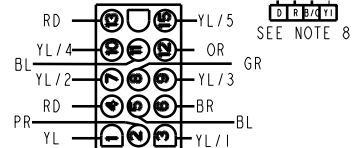

TO USER INTERFACE (SEE NOTE 2)
TO PERSONALITY MODULE (SEE NOTE 3)

⚠ CAUTION

Label all wires prior to disconnection when servicing controls. Wiring errors can cause improper and dangerous operation. Verify proper operation after servicing.

Service Facts

*UH3 SCHEMATIC DIAGRAM

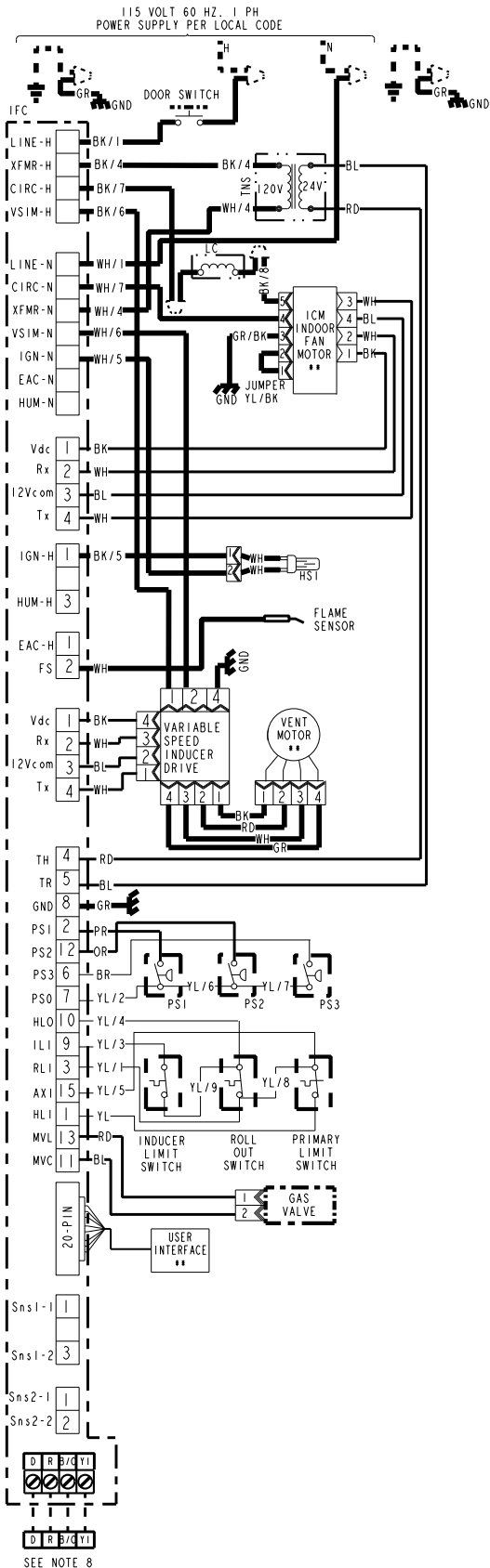

DIAGNOSTIC CODES (SEE NOTE 10)	
RED LED - FAULT Data - 1 Flash every 20 seconds	
2 FLASHES - SYSTEM LOCKOUT RETRIES OR RECYCLES EXCEEDED	6 FLASHES - 115 VOLT AC POWER REVERSED OR IGNITER FAULT
3 FLASHES - PRESSURE SWITCH FAULT	7 FLASHES - GAS VALVE CIRCUIT ERROR
4 FLASHES - OPEN LIMIT SWITCH	8 FLASHES - LOW FLAME SENSE SIGNAL
5 FLASHES - FLAME SENSED WHEN NO FLAME SHOULD BE PRESENT	9 FLASHES - OPEN INDUCER LIMIT
	10 FLASHES - COMMUNICATION FAULT
CONTINUOUS ON - INTERNAL CONTROL FAILURE	
GREEN LED - STATUS	
SLOW FLASH - NORMAL, NO CALL FOR HEAT	
FAST FLASH - NORMAL, CALL FOR HEAT PRESENT	
GREEN AND RED LED'S ON CONTINUOUS - INTERNAL CONTROL FAILURE	
GREEN AND RED LED'S OFF CONTINUOUS - FUSE OPEN	

WARNING ⚠	CAUTION ⚠
HAZARDOUS VOLTAGE DISCONNECT ALL ELECTRICAL POWER INCLUDING REMOTE DISCONNECTS BEFORE SERVICING. FAILURE TO DISCONNECT POWER BEFORE SERVICING CAN CAUSE SEVERE PERSONAL INJURY OR DEATH.	USE COPPER CONDUCTORS ONLY! UNIT TERMINALS ARE NOT DESIGNED TO ACCEPT OTHER TYPES OF CONDUCTORS. FAILURE TO DO SO MAY CAUSE DAMAGE TO THE EQUIPMENT.

INTEGRATED FURNACE CONTROL

REPLACE WITH PART CNT 04829 OR EQUIVALENT

ELECTRICAL RATING
INPUT: 25 V.A.C., 60 HZ.
XFMR SEC. CURRENT: 450 MA. + MV LOAD
MV OUTPUT: 1.5 A @ 24 V.A.C.
IND OUTPUT: 3 PHASE OUTPUT
IGN OUTPUT: 2.0 A @ 120V.A.C.
CIRC. BLOWER OUTPUT: 14.5 FLA,
25 LRA @ 120 VAC
HUMIDIFIER & AIR CLEANER
MAX. LOAD: 1.0 A @ 120 VAC

TIMINGS
PREPURGE: 0 SEC.; INTERPURGE: 60 SEC.
POST PURGE: 5 SECONDS
IGNITOR WARMUP: 20 SECONDS
IAP: 3; TFI: 5 SECONDS
RETRIES: 2; RECYCLES: 10
HEAT ON DELAY: 45 SECONDS
COOL ON DELAY: 0 SECONDS
AUTO RESTART: 60 MINUTES
AUTO RESTART PURGE: 15 SECONDS

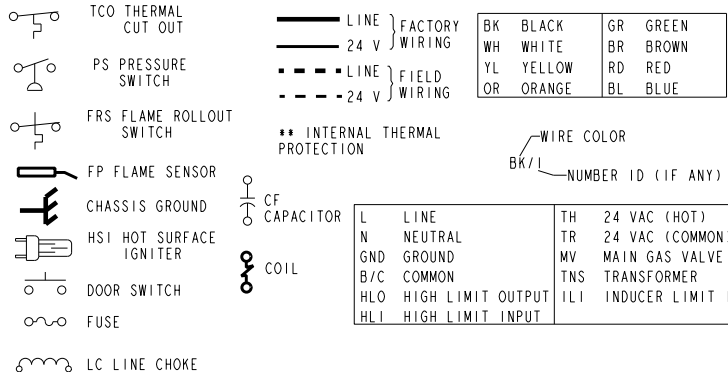

NOTES:

- IF ANY OF THE ORIGINAL WIRING AS SUPPLIED WITH THIS FURNACE MUST BE REPLACED, IT MUST BE WITH WIRE HAVING A TEMPERATURE RATING OF AT LEAST 105 C.
- USER INTERFACE MUST BE INSTALLED FOR PROPER FURNACE INSTALLATION & SET-UP.
- CORRECT PERSONALITY MODULE IS REQUIRED FOR PROPER FURNACE OPERATION. PERSONALITY MODULE IS SPECIFIC TO EACH MODEL & SERIAL NUMBER, AND IS TO REMAIN WITHIN IT'S ORIGINAL UNIT.
- THESE LEADS PROVIDE 120V POWER CONNECTIONS FOR ELECTRONIC AIR CLEANER (EAC) AND HUMIDIFIER (HUM). MAX. LOAD: 1.0 AMPS EACH.
- REVERSE FLOW SWITCH NOT PRESENT ON MODELS LISTED IN TABLE "A". CONTROL INPUT IS JUMPED USING YL/5.
- USED FOR *UH3C100ACV4V*, *UX3C100ACV4V* AND *UH3D120ACV5V*, *UX3D120ACV5V* MODELS ONLY.
- ON POWER-UP, LAST FOUR FAULTS, IF ANY, WILL BE FLASHED ON RED LED. GREEN LED WILL BE SOLID ON DURING LAST FAULT RECOVERY.
- Y1 IS OUTPUT TO NON-COMMUNICATING OUTDOOR UNIT.

⚠ CAUTION

Label all wires prior to disconnection when servicing controls. Wiring errors can cause improper and dangerous operation. Verify proper operation after servicing.

*DH3 WIRING DIAGRAM

15-PIN CONNECTOR	
1.	HL1 HIGH LIMIT INPUT
2.	PS1 PRESSURE SWITCH 1ST STAGE
3.	RL1 ROLL OUT SWITCH INPUT
4.	TH 24VAC
5.	TR 24V RETURN
6.	PS3 PRESSURE SWITCH 3RD STAGE
7.	PS0 PRESSURE SWITCH OUTPUT
8.	GND GROUND
9.	IL1 INDUCER LIMIT INPUT
10.	HLO LIMIT SWITCH OUTPUT
11.	MVC VALVE COMMON
12.	PS2 PRESSURE SWITCH 2ND STAGE
13.	MVL VALVE
14.	(NOT USED)
15.	AX1 REVERSE FLOW SWITCH INPUT

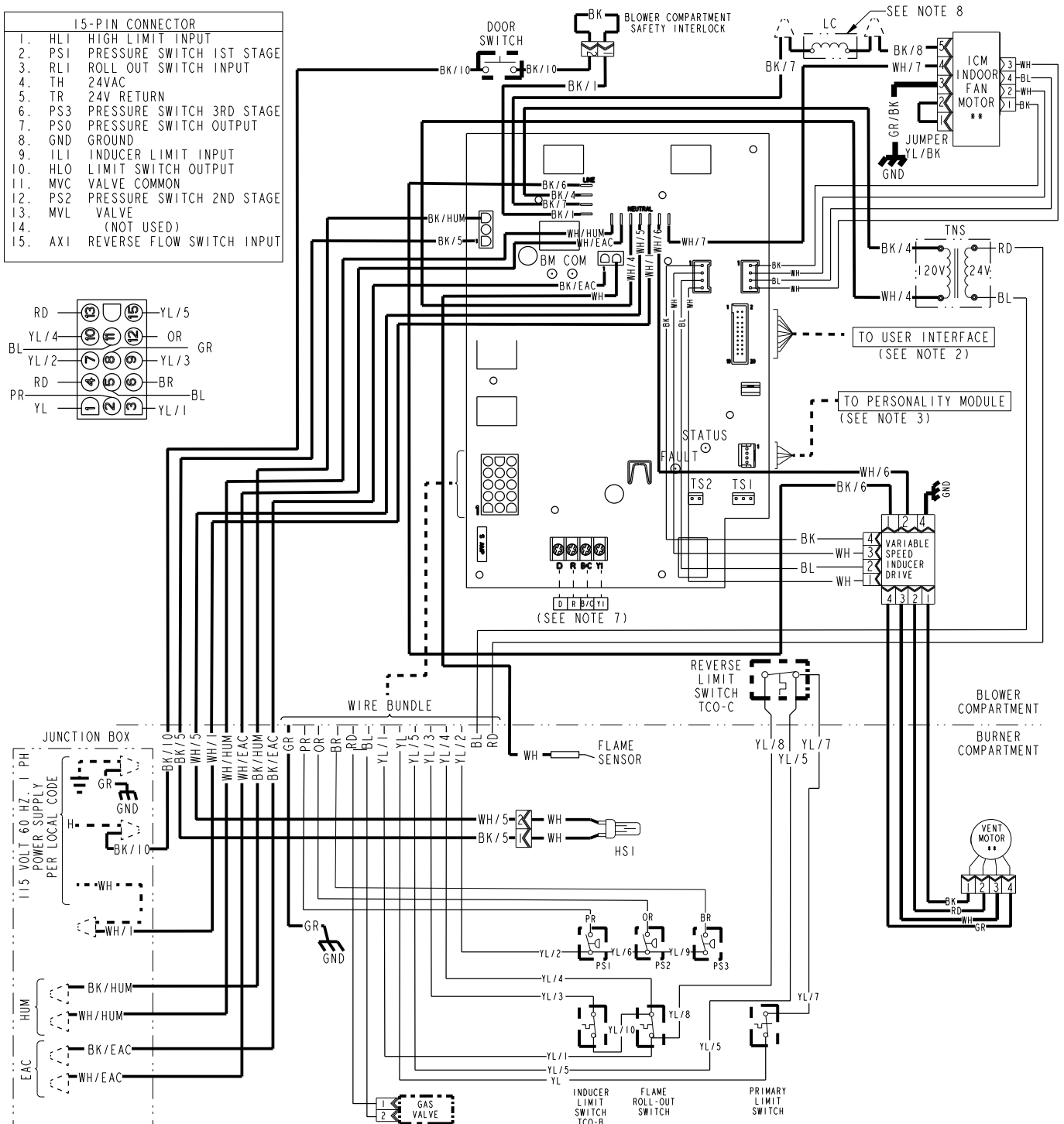
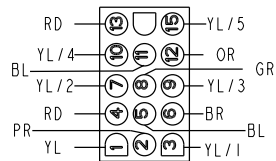

IMPORTANT:
 INTEGRATED CONTROL IS POLARITY SENSITIVE.
 HOT LEG OF 120V POWER SUPPLY MUST BE CONNECTED
 TO THE BLACK POWER LEAD AS INDICATED ON WIRING DIAGRAM.

TABLE "A"	
MODELS	
*DH3B060ACV3V^^	*DH3B080ACV3V^^
*DX3B060ACV3V^^	*DX3B080ACV3V^^
*DH3C100ACV4V^^	*DH3D120ACV5V^^
*DX3C100ACV4V^^	*DX3D120ACV5V^^

* PREFIX MAY BE "A" OR "T" / ^^ SUFFIX MAY BE AA THROUGH ZZ

⚠ CAUTION

Label all wires prior to disconnection when servicing controls. Wiring errors can cause improper and dangerous operation. Verify proper operation after servicing.

*DH3 SCHEMATIC DIAGRAM

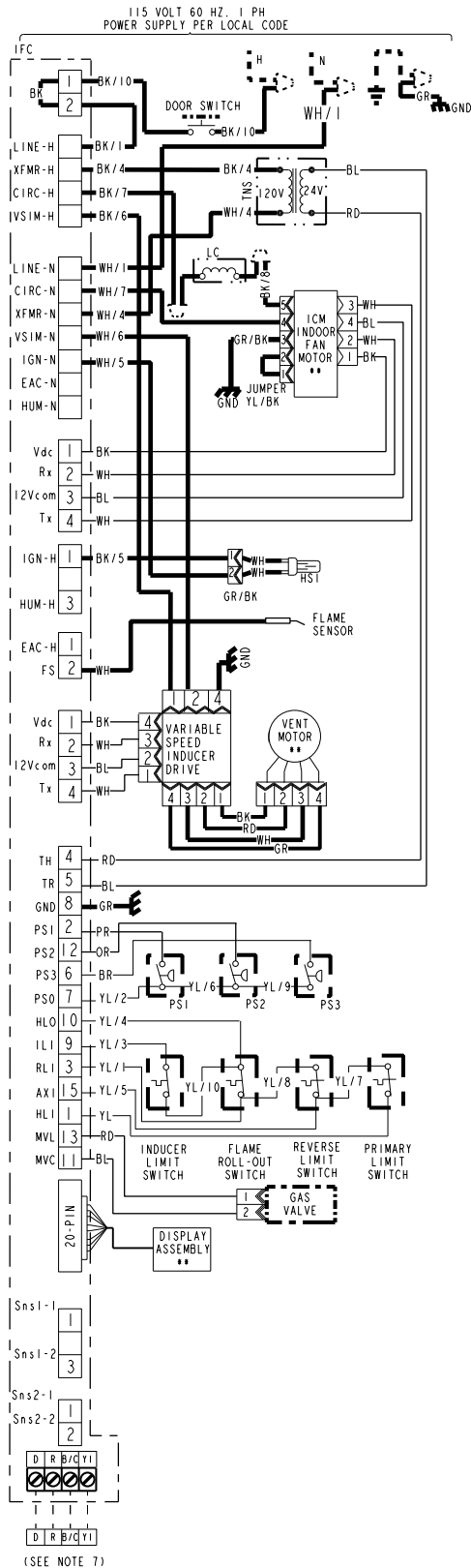

DIAGNOSTIC CODES (SEE NOTE 9)	
RED LED - FAULT Data - 1 Flash every 20 seconds	
2 FLASHES - SYSTEM LOCKOUT RETRIES OR RECYCLES EXCEEDED	6 FLASHES - 115 VOLT AC POWER REVERSED OR IGNITER FAULT
3 FLASHES - PRESSURE SWITCH FAULT	7 FLASHES - GAS VALVE CIRCUIT ERROR
4 FLASHES - OPEN LIMIT SWITCH	8 FLASHES - LOW FLAME SENSE SIGNAL
5 FLASHES - FLAME SENSED WHEN NO FLAME SHOULD BE PRESENT	9 FLASHES - OPEN INDUCER LIMIT
	10 FLASHES - COMMUNICATION FAULT
	CONTINUOUS ON - INTERNAL CONTROL FAILURE
GREEN LED - STATUS	
SLOW FLASH - NORMAL, NO CALL FOR HEAT	
FAST FLASH - NORMAL, CALL FOR HEAT PRESENT	
GREEN AND RED LED'S ON CONTINUOUS - INTERNAL CONTROL FAILURE	
GREEN AND RED LED'S OFF CONTINUOUS - FUSE OPEN	

WARNING	CAUTION
HAZARDOUS VOLTAGE DISCONNECT ALL ELECTRICAL POWER INCLUDING REMOTE DISCONNECTS BEFORE SERVICING. FAILURE TO DISCONNECT POWER BEFORE SERVICING CAN CAUSE SEVERE PERSONAL INJURY OR DEATH.	USE COPPER CONDUCTORS ONLY! UNIT TERMINALS ARE NOT DESIGNED TO ACCEPT OTHER TYPES OF CONDUCTORS. FAILURE TO DO SO MAY CAUSE DAMAGE TO THE EQUIPMENT.

INTEGRATED FURNACE CONTROL

REPLACE WITH PART CNT 04829 OR EQUIVALENT
ELECTRICAL RATING
INPUT: 25 V.A.C., 60 HZ.
XFMR SEC. CURRENT: 450 MA. + MV LOAD
MV OUTPUT: 1.5 A @ 24 V.A.C.
IND OUTPUT: 3 PHASE OUTPUT
IGN OUTPUT: 2.0 A @ 120V.A.C.
CIRC. BLOWER OUTPUT: 14.5 FLA,
25 LRA @ 120 VAC
HUMIDIFIER & AIR CLEANER
MAX. LOAD: 1.0 A @ 120 VAC

TIMINGS
PREPURGE: 0 SEC.; INTERPURGE: 60 SEC.
POST PURGE: 5 SECONDS
IGNITOR WARMUP: 20 SECONDS
IAP: 3; TFI: 5 SECONDS
RETRIES: 2; RECYCLES: 10
HEAT ON DELAY: 45 SECONDS
COOL ON DELAY: 0 SECONDS
AUTO RESTART: 60 MINUTES
AUTO RESTART PURGE: 15 SECONDS

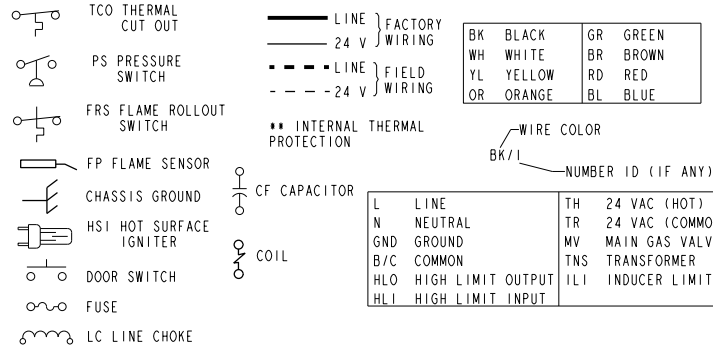

NOTES:

- IF ANY OF THE ORIGINAL WIRING AS SUPPLIED WITH THIS FURNACE MUST BE REPLACED, IT MUST BE WITH WIRE HAVING A TEMPERATURE RATING OF AT LEAST 105 C.
- USER INTERFACE MUST BE INSTALLED FOR PROPER FURNACE INSTALLATION & SET-UP.
- CORRECT PERSONALITY MODULE IS REQUIRED FOR PROPER FURNACE OPERATION. PERSONALITY MODULE IS SPECIFIC TO EACH MODEL & SERIAL NUMBER, AND IS TO REMAIN WITHIN IT'S ORIGINAL UNIT.
- THESE LEADS PROVIDE 120V POWER CONNECTIONS FOR ELECTRONIC AIR CLEANER (EAC) AND HUMIDIFIER (HUM). MAX. LOAD: 1.0 AMPS EACH.
- USED FOR *DH3C100ACV4V*, *DX3C100ACV4V* AND *DH3D120ACV5V*, *DX3D120ACV5V* MODELS ONLY.
- ON POWER-UP, LAST FOUR FAULTS, IF ANY, WILL BE FLASHED ON RED LED. GREEN LED WILL BE SOLID ON DURING LAST FAULT RECOVERY.
- Y1 IS OUTPUT TO NON-COMMUNICATING OUTDOOR UNIT.

CAUTION

Label all wires prior to disconnection when servicing controls. Wiring errors can cause improper and dangerous operation. Verify proper operation after servicing.

*UH3 AIRFLOW - HEATING

*UH3B060ACV3VA Furnace Heating Airflow (CFM) and Power (watts) vs. External Static Pressure With Filter								
	Airflow Setting	Target Airflow		External Static Pressure				
				0.1	0.3	0.5	0.7	0.9
Heating	Heating 1st Stage	Low	CFM	446	575	590	608	611
			Temp. Rise	46	36	35	34	34
			Watts	44	82	115	154	191
		Medium Low	CFM	543	637	647	665	668
			Temp. Rise	38	32	32	31	31
			Watts	51	93	130	171	211
	Medium**	CFM	622	705	715	729	731	
		Temp. Rise	33	29	29	28	28	
		Watts	63	108	148	191	234	
	High	CFM	727	795	804	815	815	
		Temp. Rise	28	26	26	25	25	
		Watts	84	132	176	223	268	
Heating 2nd Stage	Low	CFM	619	695	717	727	733	
		Temp. Rise	50	45	43	43	42	
		Watts	63	106	150	193	236	
	Medium Low	CFM	710	780	789	801	801	
		Temp. Rise	44	40	39	39	39	
		Watts	80	128	171	217	262	
Medium**	CFM	819	874	882	890	888		
	Temp. Rise	38	35	35	35	35		
	Watts	107	158	205	255	303		
High	CFM	939	978	985	989	984		
	Temp. Rise	33	32	31	31	31		
	Watts	145	200	251	304	355		
Heating 3rd Stage	Low	CFM	937	968	977	985	984	
		Temp. Rise	55	53	53	52	53	
		Watts	136	193	241	295	343	
	Medium Low	CFM	985	1017	1024	1027	1021	
		Temp. Rise	52	51	50	50	51	
		Watts	162	218	272	325	377	
Medium**	CFM	1117	1130	1136	1134	1126		
	Temp. Rise	46	46	45	46	46		
	Watts	219	279	338	392	449		
High	CFM	1292	1280	1285	1278	1201		
	Temp. Rise	40	40	40	40	43		
	Watts	317	383	448	501	508		

*UH3B080ACV3VA Furnace Cooling Airflow (CFM) and Power (Watts) vs. External Static Pressure With Filter								
	Airflow Setting	Target Airflow		External Static Pressure				
				0.1	0.3	0.5	0.7	0.9
Heating	Heating 1st Stage	Low	CFM	603	656	675	609	629
			Temp. Rise	46	42	41	45	44
			Watts	49	87	123	160	197
		Medium Low	CFM	694	740	755	689	710
			Temp. Rise	40	37	36	40	39
			Watts	65	106	144	183	222
	Medium**	CFM	817	837	845	838	825	
		Temp. Rise	34	33	33	33	33	
		Watts	87	128	171	210	250	
	High	CFM	920	950	958	890	912	
		Temp. Rise	30	29	29	31	30	
		Watts	119	167	212	256	302	
Heating 2nd Stage	Low	CFM	747	790	804	737	758	
		Temp. Rise	65	61	60	65	64	
		Watts	76	118	158	198	239	
	Medium Low	CFM	856	891	901	833	855	
		Temp. Rise	56	54	54	58	56	
		Watts	102	147	191	233	277	
Medium**	CFM	965	992	998	930	952		
	Temp. Rise	50	49	48	52	51		
	Watts	133	182	229	274	321		
High	CFM	1127	1142	1144	1074	1098		
	Temp. Rise	43	42	42	45	44		
	Watts	191	246	299	349	400		
Heating 3rd Stage	Low	CFM	1099	1106	1111	1108	1103	
		Temp. Rise	63	62	62	62	62	
		Watts	174	229	278	330	382	
	Medium Low	CFM	1232	1239	1243	1241	1235	
		Temp. Rise	56	56	55	56	56	
		Watts	234	292	349	407	463	
Medium**	CFM	1375	1385	1384	1383	1305		
	Temp. Rise	50	50	50	50	53		
	Watts	316	383	444	513	513		
High	CFM	1612	1566	1491	1392	1303		
	Temp. Rise	43	44	46	49	53		
	Watts	470	513	513	513	513		

Notes:
 1. * First letter may be "A" or "T".
 2. ** Factory setting.
 3. Continuous Fan Setting: Heating or cooling airflow is approximately 50% of selected cooling value.
 4. LOW 350 cfm/ton is recommended for variable speed application for COMFORT & HUMID CLIMATE setting; NORMAL is 400 cfm/ton; HIGH 450 cfm/ton is for DRY CLIMATE setting.
 5. Target airflow is field selectable for third stage heating. Target airflow for first and second stage heating are percentages of third stage target and are not field selectable.

Service Facts

*UH3 AIRFLOW - HEATING

		*UH3C100ACV4VA Furnace Cooling Airflow (CFM) and Power (Watts) vs. External Static Pressure With Filter						
Heating	Airflow Setting	Target Airflow		External Static Pressure				
				0.1	0.3	0.5	0.7	0.9
Heating 1st Stage	Low	800	CFM	788	806	810	804	792
			Temp. Rise	45	44	43	44	44
			Watts	91	132	172	212	250
	Medium Low	890	CFM	880	896	899	892	879
			Temp. Rise	40	39	39	39	40
			Watts	109	152	195	237	277
	Medium**	1010	CFM	1010	1023	1023	1016	1002
			Temp. Rise	35	34	34	35	35
			Watts	139	185	232	279	322
	High	1080	CFM	1077	1089	1088	1080	1066
			Temp. Rise	32	32	32	32	32
			Watts	157	205	254	304	349
Heating 2nd Stage	Low	960	CFM	951	966	967	960	947
			Temp. Rise	65	64	64	64	65
			Watts	124	169	214	259	301
	Medium Low	1060	CFM	1061	1073	1072	1064	1051
			Temp. Rise	58	57	57	58	59
			Watts	153	200	249	297	342
	Medium**	1220	CFM	1217	1226	1223	1214	1199
			Temp. Rise	51	50	50	51	51
			Watts	203	255	309	363	413
	High	1300	CFM	1298	1305	1300	1291	1276
			Temp. Rise	47	47	47	48	48
			Watts	234	289	346	403	456
Heating 3rd Stage	Low	1330	CFM	1333	1339	1334	1324	1309
			Temp. Rise	66	66	66	66	67
			Watts	249	305	363	421	476
	Medium Low	1480	CFM	1486	1489	1481	1471	1454
			Temp. Rise	59	59	59	60	60
			Watts	322	384	448	513	576
	Medium**	1690	CFM	1701	1699	1687	1676	1658
			Temp. Rise	52	52	52	52	53
			Watts	453	526	599	672	752
	High	1800	CFM	1813	1810	1795	1783	1765
			Temp. Rise	49	49	49	49	50
			Watts	536	617	694	772	864

		*UH3D120ACV5VA Furnace Heating Airflow (CFM) and Power (Watts) vs. External Static Pressure With Filter						
Heating	Airflow Setting	Target Airflow		External Static Pressure				
				0.1	0.3	0.5	0.7	0.9
Heating 1st Stage	Low	1000	CFM	903	939	951	957	958
			Temp. Rise	46	44	43	43	43
			Watts	107	156	203	250	298
	Medium Low	1110	CFM	1019	1049	1061	1065	1065
			Temp. Rise	41	39	39	39	39
			Watts	136	188	239	290	342
	Medium**	1220	CFM	1134	1160	1171	1172	1173
			Temp. Rise	36	36	35	35	35
			Watts	172	227	282	338	394
	High	1400	CFM	1316	1336	1344	1342	1342
			Temp. Rise	31	31	31	31	31
			Watts	245	307	368	431	495
Heating 2nd Stage	Low	1200	CFM	1105	1132	1143	1145	1145
			Temp. Rise	65	64	63	63	63
			Watts	162	217	270	325	380
	Medium Low	1330	CFM	1243	1265	1275	1274	1274
			Temp. Rise	58	57	57	57	57
			Watts	213	272	331	391	452
	Medium**	1470	CFM	1382	1399	1407	1403	1403
			Temp. Rise	52	52	51	52	52
			Watts	277	341	405	471	538
	High	1690	CFM	1600	1609	1614	1606	1606
			Temp. Rise	45	45	45	45	45
			Watts	409	484	559	630	707
Heating 3rd Stage	Low	1660	CFM	1575	1585	1590	1583	1583
			Temp. Rise	66	65	65	65	65
			Watts	392	466	538	610	685
	Medium Low	1850	CFM	1761	1781	1777	1780	1781
			Temp. Rise	59	58	58	58	58
			Watts	538	627	702	779	862
	Medium**	2040	CFM	1959	1954	1956	1916	1844
			Temp. Rise	53	53	53	54	56
			Watts	734	831	929	966	966
	High	2340	CFM	2146	2057	1983	1916	1844
			Temp. Rise	48	50	52	54	56
			Watts	966	966	966	966	966

Notes:
 1. * First letter may be "A" or "T".
 2. ** Factory setting.
 3. Continuous Fan Setting: Heating or cooling airflow is approximately 50% of selected cooling value.
 4. LOW 350 cfm/ton is recommended for variable speed application for COMFORT & HUMID CLIMATE setting; NORMAL is 400 cfm/ton; HIGH 450 cfm/ton is for DRY CLIMATE setting.
 5. Target airflow is field selectable for third stage heating. Target airflow for first and second stage heating are percentages of third stage target and are not field selectable.

*UH3 AIRFLOW - COOLING

*UH3B060ACV3VA Furnace Cooling Airflow (CFM) and Power (Watts) vs. External Static Pressure With Filter								
Unit	Airflow Setting	External Static Pressure						
		0.1	0.3	0.5	0.7	0.9		
Cooling	1.5	290 CFM/ton	CFM	356	476	488	511	519
			Watts	29	67	97	132	167
		310 CFM/ton	CFM	389	504	516	538	545
			Watts	32	71	102	138	174
		330 CFM/ton	CFM	422	533	544	565	572
			Watts	36	75	107	144	181
		350 CFM/ton	CFM	455	561	566	589	592
			Watts	39	79	111	150	187
		370 CFM/ton	CFM	487	589	600	619	624
			Watts	43	84	119	158	197
		400 CFM/ton	CFM	537	631	655	669	673
			Watts	50	92	130	171	212
		430 CFM/ton	CFM	586	674	684	700	702
			Watts	57	101	139	182	223
		450 CFM/ton	CFM	619	695	717	727	733
			Watts	63	106	150	193	236
2	290 CFM/ton	CFM	515	613	623	641	646	
		Watts	47	88	124	164	204	
	310 CFM/ton	CFM	559	650	660	677	681	
		Watts	53	96	133	175	215	
	330 CFM/ton	CFM	602	688	698	713	716	
		Watts	60	104	143	186	228	
	350 CFM/ton	CFM	646	707	737	748	752	
		Watts	68	112	156	200	243	
	370 CFM/ton	CFM	690	763	772	785	785	
		Watts	76	123	165	211	255	
400 CFM/ton	CFM	764	816	778	847	844		
	Watts	86	137	180	231	275		
430 CFM/ton	CFM	821	876	884	892	890		
	Watts	108	159	206	256	303		
450 CFM/ton	CFM	937	968	977	985	984		
	Watts	136	193	241	295	343		
2.5	290 CFM/ton	CFM	673	749	758	771	772	
		Watts	73	119	161	206	250	
	310 CFM/ton	CFM	732	791	756	766	818	
		Watts	79	129	160	203	268	
	330 CFM/ton	CFM	783	843	852	861	860	
		Watts	98	147	193	242	288	
	350 CFM/ton	CFM	848	894	908	917	917	
		Watts	110	163	212	262	308	
	370 CFM/ton	CFM	892	937	945	951	947	
		Watts	129	182	232	284	333	
400 CFM/ton	CFM	972	1015	972	957	1036		
	Watts	160	213	262	312	374		
430 CFM/ton	CFM	1057	1078	1085	1085	1078		
	Watts	191	249	306	360	415		
450 CFM/ton	CFM	1115	1137	1142	1140	1139		
	Watts	214	275	333	388	447		
3	290 CFM/ton	CFM	832	885	894	901	899	
		Watts	111	162	210	260	308	
	310 CFM/ton	CFM	898	942	950	955	951	
		Watts	131	184	234	286	336	
	330 CFM/ton	CFM	964	998	1006	1009	1004	
		Watts	154	209	262	314	366	
	350 CFM/ton	CFM	1039	1065	1073	1074	1075	
		Watts	181	237	292	344	402	
	370 CFM/ton	CFM	1095	1111	1118	1116	1108	
		Watts	208	268	326	380	436	
400 CFM/ton	CFM	1189	1212	1214	1149	1207		
	Watts	257	320	380	435	500		
430 CFM/ton	CFM	1292	1280	1285	1278	1201		
	Watts	317	383	448	501	508		
450 CFM/ton	CFM	1326	1317	1361	1242	1166		
	Watts	366	433	495	510	509		

Notes:

- * First letter may be "A" or "T".
- ** Factory setting.
- Continuous Fan Setting: Heating or cooling airflow is approximately 50% of selected cooling value.
- For variable speed low speed airflows are approximately 30% of listed values.
- LOW 350 cfm/ton is recommended for variable speed application for COMFORT & HUMID CLIMATE setting; NORMAL is 400 cfm/ton; HIGH 450 cfm/ton is for DRY CLIMATE setting.

NOTE:

CONTINUOUS fan mode during COOLING operation may not be appropriate in humid climates. If the indoor air exceeds 60% relative humidity or simply feels uncomfortably humid, it is recommended that the fan only be used in the AUTO mode.

Service Facts

*UH3 AIRFLOW - COOLING

*UH3B080ACV3VA Furnace Cooling Airflow (CFM) and Power (Watts) vs. External Static Pressure With Filter							
Unit Outdoor	Airflow Setting	External Static Pressure					
		0.1	0.3	0.5	0.7	0.9	
2	290 CFM/ton	CFM	504	565	586	521	540
		Watts	34	70	104	138	172
	310 CFM/ton	CFM	547	604	624	559	579
		Watts	40	77	112	147	182
	330 CFM/ton	CFM	590	644	663	597	617
		Watts	47	85	121	157	193
	350 CFM/ton	CFM	656	695	701	703	694
		Watts	54	93	130	167	204
	370 CFM/ton	CFM	676	724	740	674	694
		Watts	62	102	140	179	217
	400 CFM/ton	CFM	764	792	801	795	789
		Watts	75	116	157	197	238
	430 CFM/ton	CFM	806	844	856	788	810
		Watts	89	133	175	216	259
	450 CFM/ton	CFM	877	899	901	895	886
		Watts	102	145	188	230	275
2.5	290 CFM/ton	CFM	660	709	726	659	680
		Watts	59	99	136	174	212
	310 CFM/ton	CFM	740	768	772	769	764
		Watts	70	109	149	189	229
	330 CFM/ton	CFM	768	809	822	755	776
		Watts	81	123	164	205	246
	350 CFM/ton	CFM	848	869	871	868	858
		Watts	94	138	179	220	265
	370 CFM/ton	CFM	875	909	918	850	872
		Watts	107	153	197	240	284
	400 CFM/ton	CFM	978	994	992	989	980
		Watts	130	179	224	270	316
	430 CFM/ton	CFM	1037	1058	1063	994	1017
		Watts	157	209	258	305	354
	450 CFM/ton	CFM	1093	1096	1082	1065	1051
		Watts	174	227	276	324	378
3	290 CFM/ton	CFM	816	854	865	798	819
		Watts	92	136	178	220	262
	310 CFM/ton	CFM	881	914	923	855	877
		Watts	108	155	199	242	286
	330 CFM/ton	CFM	945	974	981	912	935
		Watts	127	176	222	266	313
	350 CFM/ton	CFM	1029	1043	1043	1035	1028
		Watts	148	199	246	292	340
	370 CFM/ton	CFM	1074	1093	1097	1027	1050
		Watts	170	224	274	322	372
	400 CFM/ton	CFM	1170	1181	1184	1180	1174
		Watts	206	262	317	370	423
	430 CFM/ton	CFM	1268	1273	1270	1199	1224
		Watts	254	314	372	430	484
	450 CFM/ton	CFM	1321	1321	1306	1295	1251
		Watts	287	351	415	477	518
3.5	290 CFM/ton	CFM	972	998	1005	936	959
		Watts	135	185	232	277	324
	310 CFM/ton	CFM	1047	1068	1073	1003	1026
		Watts	161	213	262	310	359
	330 CFM/ton	CFM	1123	1138	1140	1070	1094
		Watts	189	244	296	347	398
	350 CFM/ton	CFM	1195	1204	1208	1205	1195
		Watts	215	275	329	383	437
	370 CFM/ton	CFM	1273	1278	1275	1204	1228
		Watts	257	317	376	433	488
	400 CFM/ton	CFM	1375	1385	1384	1383	1305
		Watts	316	383	444	513	513
	430 CFM/ton	CFM	1499	1487	1491	1392	1303
		Watts	389	457	513	513	513
	450 CFM/ton	CFM	1513	1512	1508	1418	1341
		Watts	398	470	529	524	522

Cooling

- Notes:
- * First letter may be "A" or "T".
 - ** Factory setting.
 - Continuous Fan Setting: Heating or cooling airflow is approximately 50% of selected cooling value.
 - For variable speed low speed airflows are approximately 30% of listed values.
 - LOW 350 cfm/ton is recommended for variable speed application for COMFORT & HUMID CLIMATE setting; NORMAL is 400 cfm/ton; HIGH 450 cfm/ton is for DRY CLIMATE setting.

NOTE:
CONTINUOUS fan mode during COOLING operation may not be appropriate in humid climates. If the indoor air exceeds 60% relative humidity or simply feels uncomfortably humid, it is recommended that the fan only be used in the AUTO mode.

*UH3 AIRFLOW - COOLING

*UH3C100ACV4VA Furnace Cooling Airflow (CFM) and Power (Watts) vs. External Static Pressure With Filter								
Unit Outdoor	Airflow Setting		External Static Pressure					
			0.1	0.3	0.5	0.7	0.9	
2.5	290 CFM/ton	CFM	714	734	739	733	722	
		Watts	79	118	157	194	231	
	310 CFM/ton	CFM	765	784	789	782	770	
		Watts	88	128	168	206	244	
	330 CFM/ton	CFM	816	834	838	831	819	
		Watts	96	138	179	220	258	
	350 CFM/ton	CFM	868	884	887	880	867	
		Watts	106	149	192	234	273	
	370 CFM/ton	CFM	919	934	936	929	916	
		Watts	117	161	205	249	290	
	400 CFM/ton	CFM	995	1009	1009	1002	989	
		Watts	135	181	227	274	316	
	430 CFM/ton	CFM	1072	1084	1083	1075	1061	
		Watts	156	204	253	302	346	
	450 CFM/ton	CFM	1123	1134	1132	1124	1110	
		Watts	171	220	271	322	368	
	3	290 CFM/ton	CFM	862	879	882	875	863
			Watts	105	148	190	232	272
310 CFM/ton		CFM	924	939	941	934	921	
		Watts	118	162	207	250	291	
330 CFM/ton		CFM	985	999	1000	992	979	
		Watts	133	178	224	270	313	
350 CFM/ton		CFM	1046	1059	1059	1051	1037	
		Watts	149	196	244	292	336	
370 CFM/ton		CFM	1108	1119	1117	1109	1095	
		Watts	167	215	265	316	362	
400 CFM/ton		CFM	1200	1209	1206	1197	1183	
		Watts	197	248	301	355	404	
430 CFM/ton	CFM	1292	1299	1294	1285	1270		
	Watts	232	286	343	400	453		
450 CFM/ton	CFM	1353	1359	1353	1344	1328		
	Watts	258	314	373	432	488		
3.5	290 CFM/ton	CFM	1011	1024	1024	1017	1003	
		Watts	139	185	232	279	322	
	310 CFM/ton	CFM	1082	1094	1093	1085	1071	
		Watts	159	207	256	306	351	
	330 CFM/ton	CFM	1154	1164	1162	1153	1139	
		Watts	181	231	283	335	382	
	350 CFM/ton	CFM	1225	1234	1230	1222	1207	
		Watts	206	258	312	367	417	
	370 CFM/ton	CFM	1297	1304	1299	1290	1275	
		Watts	234	288	345	402	455	
	400 CFM/ton	CFM	1404	1409	1402	1393	1377	
		Watts	281	340	400	462	520	
430 CFM/ton	CFM	1512	1514	1505	1495	1478		
	Watts	336	399	464	530	595		
450 CFM/ton	CFM	1583	1584	1574	1564	1546		
	Watts	377	444	512	580	650		
4	290 CFM/ton	CFM	1159	1169	1167	1158	1144	
		Watts	183	233	285	337	385	
	310 CFM/ton	CFM	1241	1249	1245	1236	1221	
		Watts	212	264	319	374	425	
	330 CFM/ton	CFM	1323	1329	1324	1315	1299	
		Watts	244	300	358	416	470	
	350 CFM/ton	CFM	1404	1409	1402	1393	1377	
		Watts	281	340	400	462	520	
	370 CFM/ton	CFM	1486	1489	1481	1471	1454	
		Watts	322	384	448	513	576	
	400 CFM/ton	CFM	1609	1609	1599	1588	1571	
		Watts	393	461	530	599	671	
430 CFM/ton	CFM	1732	1730	1716	1705	1687		
	Watts	475	550	624	698	781		
450 CFM/ton	CFM	1813	1810	1795	1783	1765		
	Watts	536	617	694	772	864		

Notes:

- * First letter may be "A" or "T".
- ** Factory setting.
- Continuous Fan Setting: Heating or cooling airflow is approximately 50% of selected cooling
- For variable speed low speed airflows are approximately 30% of listed values.
- LOW 350 cfm/ton is recommended for variable speed application for COMFORT & HUMID CLIMATE setting; NORMAL is 400 cfm/ton; HIGH 450 cfm/ton is for DRY CLIMATE setting.

NOTE:

CONTINUOUS fan mode during COOLING operation may not be appropriate in humid climates. If the indoor air exceeds 60% relative humidity or simply feels uncomfortably humid, it is recommended that the fan only be used in the AUTO mode.

Service Facts

*UH3 AIRFLOW - COOLING

*UH3D120ACV5VA Furnace Cooling Airflow (CFM) and Power (Watts) vs. External Static Pressure With Filter							
Unit Outdoor	Airflow Setting		External Static Pressure				
			0.1	0.3	0.5	0.7	0.9
3.5	290 CFM/ton	CFM	922	957	970	975	976
		Watts	112	161	209	256	304
	310 CFM/ton	CFM	993	1025	1037	1041	1042
		Watts	129	180	231	281	332
	330 CFM/ton	CFM	1064	1093	1104	1107	1108
		Watts	149	203	255	308	361
	350 CFM/ton	CFM	1133	1153	1159	1158	1167
		Watts	174	228	284	338	399
	370 CFM/ton	CFM	1206	1229	1239	1239	1239
		Watts	198	256	313	372	431
	400 CFM/ton	CFM	1306	1322	1329	1330	1331
		Watts	244	305	367	429	495
	430 CFM/ton	CFM	1418	1434	1441	1437	1437
		Watts	296	362	428	495	563
	450 CFM/ton	CFM	1481	1494	1503	1504	1504
		Watts	336	405	475	543	614
4	290 CFM/ton	CFM	1069	1098	1109	1112	1112
		Watts	151	204	257	310	364
	310 CFM/ton	CFM	1150	1176	1186	1187	1188
		Watts	177	234	289	345	402
	330 CFM/ton	CFM	1231	1254	1263	1262	1263
		Watts	208	267	325	385	445
	350 CFM/ton	CFM	1306	1322	1329	1330	1331
		Watts	244	305	367	429	495
	370 CFM/ton	CFM	1393	1409	1417	1413	1413
		Watts	282	348	412	478	545
	400 CFM/ton	CFM	1509	1521	1530	1532	1533
		Watts	353	425	494	563	636
	430 CFM/ton	CFM	1636	1643	1648	1639	1639
		Watts	435	512	588	660	738
	450 CFM/ton	CFM	1709	1720	1730	1739	1743
		Watts	495	579	660	740	824
5	290 CFM/ton	CFM	1362	1380	1388	1385	1385
		Watts	267	331	394	459	525
	310 CFM/ton	CFM	1459	1470	1477	1479	1480
		Watts	322	390	458	525	596
	330 CFM/ton	CFM	1557	1564	1572	1574	1576
		Watts	381	454	526	596	669
	350 CFM/ton	CFM	1662	1670	1678	1686	1681
		Watts	454	534	614	691	767
	370 CFM/ton	CFM	1761	1781	1777	1780	1781
		Watts	538	627	702	779	862
	400 CFM/ton	CFM	1930	1944	1942	1920	1856
		Watts	696	792	873	931	934
	430 CFM/ton	CFM	2071	2057	1983	1916	1844
		Watts	866	966	966	966	966
	450 CFM/ton	CFM	2161	2103	2027	1961	1889
		Watts	969	989	985	985	984

NOTE:
CONTINUOUS fan mode during **COOLING** operation may not be appropriate in humid climates. If the indoor air exceeds 60% relative humidity or simply feels uncomfortably humid, it is recommended that the fan only be used in the **AUTO** mode.

Notes:

- * First letter may be "A" or "T".
- ** Factory setting.
- Continuous Fan Setting: Heating or cooling airflow is approximately 50% of selected cooling value.
- LOW 350 cfm/ton is recommended for variable speed application for COMFORT & HUMID CLIMATE setting; NORMAL is 400 cfm/ton; HIGH 450 cfm/ton is for DRY CLIMATE setting.

*DH3 AIRFLOW - HEATING

		*DH3B060ACV3VA Furnace Heating Airflow (CFM) and Power (watts) vs. External Static Pressure With Filter						
	Airflow Setting	Target Airflow		External Static Pressure				
				0.1	0.3	0.5	0.7	0.9
Heating	Heating 1st Stage	Low	CFM	428	488	514	523	524
			Temp. Rise	48	42	40	39	39
			Watts	41	65	98	129	159
		Medium Low	CFM	493	544	571	581	582
			Temp. Rise	41	38	36	35	35
			Watts	41	74	108	142	174
		Medium**	CFM	565	610	634	642	641
			Temp. Rise	36	34	32	32	32
			Watts	52	87	123	158	192
		High	CFM	659	694	704	705	703
			Temp. Rise	31	29	29	29	29
			Watts	69	109	144	181	221
Heating	Heating 2nd Stage	Low	CFM	563	611	625	629	626
			Temp. Rise	54	50	49	49	49
			Watts	52	88	123	159	195
		Medium Low	CFM	645	684	703	709	707
			Temp. Rise	48	45	44	43	43
			Watts	67	105	142	178	214
		Medium**	CFM	744	775	790	794	789
			Temp. Rise	41	40	39	39	39
			Watts	90	131	170	208	246
		High	CFM	854	876	885	887	879
			Temp. Rise	36	35	35	35	35
			Watts	122	166	208	249	289
Heating	Heating 3rd Stage	Low	CFM	783	807	814	813	809
			Temp. Rise	65	63	63	63	63
			Watts	102	143	182	220	260
		Medium Low	CFM	896	914	922	923	914
			Temp. Rise	57	56	55	55	56
			Watts	136	182	224	266	308
		Medium**	CFM	1015	1024	1026	1024	1012
			Temp. Rise	50	50	50	50	50
			Watts	184	233	279	325	369
		High	CFM	1172	1171	1174	1173	1172
			Temp. Rise	44	44	44	44	44
			Watts	263	317	371	422	473

		*DH3B080ACV3VA Furnace Cooling Airflow (CFM) and Power (Watts) vs. External Static Pressure With Filter						
	Airflow Setting	Target Airflow		External Static Pressure				
				0.1	0.3	0.5	0.7	0.9
Heating	Heating 1st Stage	Low	CFM	635	656	668	673	670
			Temp. Rise	43	42	41	41	41
			Watts	61	95	131	166	202
		Medium Low	CFM	726	744	755	757	753
			Temp. Rise	38	37	36	36	36
			Watts	80	118	156	193	231
		Medium**	CFM	817	833	842	842	835
			Temp. Rise	33	33	32	32	33
			Watts	104	145	184	223	263
		High	CFM	954	966	973	969	959
			Temp. Rise	29	28	28	28	28
			Watts	148	194	237	278	321
Heating	Heating 2nd Stage	Low	CFM	780	797	807	807	802
			Temp. Rise	61	60	59	59	60
			Watts	93	133	172	210	250
		Medium Low	CFM	890	904	911	909	901
			Temp. Rise	54	53	52	52	53
			Watts	126	170	211	251	293
		Medium**	CFM	999	1011	1016	1011	1000
			Temp. Rise	48	47	47	47	48
			Watts	165	213	257	300	343
		High	CFM	1163	1170	1173	1163	1148
			Temp. Rise	41	41	41	41	42
			Watts	239	291	340	388	434
Heating	Heating 3rd Stage	Low	CFM	1120	1129	1132	1124	1109
			Temp. Rise	61	60	60	61	61
			Watts	218	269	316	363	408
		Medium Low	CFM	1272	1277	1277	1265	1242
			Temp. Rise	54	53	53	54	55
			Watts	299	353	406	459	502
		Medium**	CFM	1411	1409	1386	1321	1250
			Temp. Rise	48	48	49	52	55
			Watts	396	454	503	502	501
		High	CFM	1558	1491	1408	1320	1242
			Temp. Rise	44	46	48	52	55
			Watts	502	502	502	502	502

Notes:
 1. * First letter may be "A" or "T".
 2. ** Factory setting.
 3. Continuous Fan Setting: Heating or cooling airflow is approximately 50% of selected cooling value.
 4. LOW 350 cfm/ton is recommended for variable speed application for COMFORT & HUMID CLIMATE setting; NORMAL is 400 cfm/ton; HIGH 450 cfm/ton is for DRY CLIMATE setting.
 5. Target airflow is field selectable for third stage heating. Target airflow for first and second stage heating are percentages of third stage target and are not field selectable.

Service Facts

*DH3 AIRFLOW - HEATING

*DH3C100ACV4VA Furnace Cooling Airflow (CFM) and Power (Watts) vs. External Static Pressure With Filter								
Heating	Airflow Setting	Target Airflow		External Static Pressure				
				0.1	0.3	0.5	0.7	0.9
Heating 1st Stage	Low	800	CFM	796	785	769	750	728
			Temp. Rise	43	43	44	45	47
			Watts	79	132	182	231	266
	Medium Low	890	CFM	886	874	856	835	810
			Temp. Rise	38	39	40	41	42
			Watts	107	163	215	265	308
	Medium**	1010	CFM	1012	998	977	953	925
			Temp. Rise	34	34	35	36	37
			Watts	154	212	264	315	367
	High	1080	CFM	1077	1063	1041	1016	985
			Temp. Rise	32	32	33	34	35
			Watts	181	240	292	343	398
Heating 2nd Stage	Low	960	CFM	956	943	923	901	874
			Temp. Rise	62	63	65	66	68
			Watts	132	189	242	292	340
	Medium Low	1070	CFM	1063	1049	1027	1002	973
			Temp. Rise	56	57	58	59	61
			Watts	175	234	286	337	392
	Medium**	1210	CFM	1214	1198	1173	1144	1110
			Temp. Rise	49	50	51	52	54
			Watts	246	304	354	403	463
	High	1300	CFM	1293	1275	1249	1219	1182
			Temp. Rise	46	47	48	49	50
			Watts	287	344	393	439	501
Heating 3rd Stage	Low	1330	CFM	1327	1309	1282	1251	1213
			Temp. Rise	64	65	66	68	70
			Watts	305	362	410	455	516
	Medium Low	1480	CFM	1476	1456	1426	1392	1350
			Temp. Rise	58	58	60	61	63
			Watts	395	448	489	529	584
	Medium**	1690	CFM	1686	1663	1629	1589	1542
			Temp. Rise	51	51	52	54	55
			Watts	538	583	612	639	672
	High	1800	CFM	1796	1771	1735	1693	1642
			Temp. Rise	47	48	49	50	52
			Watts	622	661	682	726	726

*DH3D120ACV5VA Furnace Cooling Airflow (CFM) and Power (Watts) vs. External Static Pressure With Filter								
Heating	Airflow Setting	Target Airflow		External Static Pressure				
				0.1	0.3	0.5	0.7	0.9
Heating 1st Stage	Low	1000	CFM	950	986	1010	1017	950
			Temp. Rise	43	41	40	40	43
			Watts	118	172	225	278	331
	Medium Low	1110	CFM	1073	1102	1120	1122	1073
			Temp. Rise	38	37	37	36	38
			Watts	152	213	274	333	390
	Medium**	1220	CFM	1197	1218	1230	1227	1197
			Temp. Rise	34	34	33	33	34
			Watts	194	260	329	393	453
	High	1400	CFM	1392	1401	1404	1393	1392
			Temp. Rise	29	29	29	29	29
			Watts	278	352	428	498	560
Heating 2nd Stage	Low	1200	CFM	1166	1189	1202	1200	1166
			Temp. Rise	61	60	60	60	61
			Watts	183	248	314	378	437
	Medium Low	1330	CFM	1314	1328	1334	1326	1314
			Temp. Rise	54	54	54	54	54
			Watts	242	313	387	455	517
	Medium**	1470	CFM	1462	1467	1466	1452	1462
			Temp. Rise	49	49	49	49	49
			Watts	315	389	468	539	600
	High	1690	CFM	1697	1687	1674	1651	1697
			Temp. Rise	42	42	43	43	42
			Watts	461	537	615	683	739
Heating 3rd Stage	Low	1660	CFM	1670	1662	1650	1628	1670
			Temp. Rise	61	61	62	63	61
			Watts	442	518	597	666	722
	Medium Low	1850	CFM	1876	1856	1833	1803	1876
			Temp. Rise	54	55	56	57	54
			Watts	602	674	744	803	847
	Medium**	2040	CFM	2082	2049	2017	2027	1946
			Temp. Rise	49	50	51	50	53
			Watts	800	859	910	1034	1031
	High	2340	CFM	2254	2180	2100	2027	1946
			Temp. Rise	45	47	49	50	53
			Watts	1007	1036	1034	1034	1031

Notes:
 1. * First letter may be "A" or "T".
 2. ** Factory setting.
 3. Continuous Fan Setting: Heating or cooling airflow is approximately 50% of selected cooling value.
 4. LOW 350 cfm/ton is recommended for variable speed application for COMFORT & HUMID CLIMATE setting; NORMAL is 400 cfm/ton; HIGH 450 cfm/ton is for DRY CLIMATE setting.
 5. Target airflow is field selectable for third stage heating. Target airflow for first and second stage heating are percentages of third stage target and are not field selectable.

*DH3 AIRFLOW - COOLING

*DH3B060ACV3VA Furnace Cooling Airflow (CFM) and Power (Watts) vs. External Static Pressure With Filter								
Unit Outdoor	Airflow Setting	External Static Pressure						
		0.1	0.3	0.5	0.7	0.9		
1.5	290 CFM/ton	CFM	272	388	423	436	442	
		Watts	24	52	82	111	141	
	310 CFM/ton	CFM	353	415	449	461	466	
		Watts	26	55	86	116	146	
	330 CFM/ton	CFM	383	443	475	487	491	
		Watts	29	59	90	121	152	
	350 CFM/ton	CFM	413	472	503	512	513	
		Watts	32	62	96	126	157	
	370 CFM/ton	CFM	443	498	527	538	540	
		Watts	35	67	99	132	163	
	400 CFM/ton	CFM	487	535	557	564	562	
		Watts	40	73	107	141	173	
	430 CFM/ton	CFM	532	580	605	614	614	
		Watts	47	81	116	150	183	
	450 CFM/ton	CFM	563	611	625	629	626	
		Watts	52	88	123	159	195	
	2	290 CFM/ton	CFM	468	520	549	559	561
			Watts	38	70	104	136	169
310 CFM/ton		CFM	507	557	583	593	593	
		Watts	43	77	111	145	177	
330 CFM/ton		CFM	547	594	618	627	626	
		Watts	49	84	119	153	187	
350 CFM/ton		CFM	585	633	647	648	647	
		Watts	56	93	129	165	203	
370 CFM/ton		CFM	627	667	688	694	692	
		Watts	63	100	137	173	208	
400 CFM/ton		CFM	686	716	725	727	725	
		Watts	76	115	151	189	228	
430 CFM/ton		CFM	746	777	792	796	790	
		Watts	90	131	170	209	247	
450 CFM/ton		CFM	783	807	814	813	809	
		Watts	102	143	182	220	260	
2.5		290 CFM/ton	CFM	612	653	675	682	680
			Watts	60	97	133	169	204
	310 CFM/ton	CFM	662	699	718	724	721	
		Watts	70	109	146	183	219	
	330 CFM/ton	CFM	711	745	761	766	762	
		Watts	82	121	160	198	235	
	350 CFM/ton	CFM	763	785	790	793	786	
		Watts	95	136	174	212	252	
	370 CFM/ton	CFM	811	837	848	851	844	
		Watts	109	151	192	232	271	
	400 CFM/ton	CFM	894	907	914	914	905	
		Watts	134	178	221	262	303	
	430 CFM/ton	CFM	960	974	978	978	967	
		Watts	161	208	252	297	339	
	450 CFM/ton	CFM	1012	1021	1025	1028	1023	
		Watts	182	231	279	324	369	
	3	290 CFM/ton	CFM	756	786	800	804	799
			Watts	93	134	173	212	250
310 CFM/ton		CFM	816	841	852	855	848	
		Watts	110	153	194	234	273	
330 CFM/ton		CFM	876	896	904	906	897	
		Watts	130	174	216	258	299	
350 CFM/ton		CFM	941	953	961	959	954	
		Watts	151	198	242	285	328	
370 CFM/ton		CFM	995	1006	1009	1007	996	
		Watts	175	223	269	314	358	
400 CFM/ton		CFM	1085	1087	1091	1092	1090	
		Watts	216	265	316	365	412	
430 CFM/ton		CFM	1172	1171	1174	1173	1172	
		Watts	263	317	371	422	473	
450 CFM/ton		CFM	1227	1227	1231	1234	1207	
		Watts	299	356	412	467	502	

Notes:

- * First letter may be "A" or "T".
- ** Factory setting.
- Continuous Fan Setting: Heating or cooling airflow is approximately 50% of selected cooling value.
- For variable speed low speed airflows are approximately 30% of listed values.
- LOW 350 cfm/ton is recommended for variable speed application for COMFORT & HUMID CLIMATE setting; NORMAL is 400 cfm/ton; HIGH 450 cfm/ton is for DRY CLIMATE setting.

NOTE:

CONTINUOUS fan mode during COOLING operation may not be appropriate in humid climates. If the indoor air exceeds 60% relative humidity or simply feels uncomfortably humid, it is recommended that the fan only be used in the AUTO mode.

Service Facts

*DH3 AIRFLOW - COOLING

*DH3B080ACV3VA Furnace Cooling Airflow (CFM) and Power (Watts) vs. External Static Pressure With Filter								
Unit Outdoor	Airflow Setting		External Static Pressure					
			0.1	0.3	0.5	0.7	0.9	
2	290 CFM/ton	CFM	535	558	572	580	580	
		Watts	44	74	108	142	175	
	310 CFM/ton	CFM	579	601	614	620	619	
		Watts	51	82	118	152	187	
	330 CFM/ton	CFM	622	643	655	660	659	
		Watts	58	92	128	163	199	
	350 CFM/ton	CFM	665	697	705	697	694	
		Watts	67	104	141	175	214	
	370 CFM/ton	CFM	709	728	738	741	737	
		Watts	76	113	151	187	225	
	400 CFM/ton	CFM	779	802	809	797	793	
		Watts	90	131	169	207	250	
	430 CFM/ton	CFM	839	854	863	862	855	
		Watts	110	152	192	231	272	
	450 CFM/ton	CFM	903	917	916	906	891	
		Watts	125	168	208	248	287	
	2.5	290 CFM/ton	CFM	692	712	723	726	722
			Watts	72	109	146	182	220
310 CFM/ton		CFM	747	765	774	776	771	
		Watts	85	123	162	199	238	
330 CFM/ton		CFM	801	817	826	827	820	
		Watts	99	140	179	217	257	
350 CFM/ton		CFM	855	870	878	877	869	
		Watts	115	157	198	237	278	
370 CFM/ton		CFM	909	923	930	927	918	
		Watts	132	177	218	259	301	
400 CFM/ton		CFM	1005	1014	1014	1003	993	
		Watts	164	211	252	295	337	
430 CFM/ton		CFM	1072	1082	1086	1078	1065	
		Watts	196	246	291	336	381	
450 CFM/ton		CFM	1126	1134	1137	1129	1114	
		Watts	221	272	319	366	411	
3		290 CFM/ton	CFM	849	865	873	872	864
			Watts	113	156	196	235	276
	310 CFM/ton	CFM	915	928	935	932	923	
		Watts	134	179	221	261	303	
	330 CFM/ton	CFM	980	992	997	993	982	
		Watts	158	205	248	290	333	
	350 CFM/ton	CFM	1045	1055	1060	1053	1041	
		Watts	184	233	278	322	366	
	370 CFM/ton	CFM	1110	1119	1122	1114	1100	
		Watts	213	264	311	357	402	
	400 CFM/ton	CFM	1211	1208	1209	1202	1195	
		Watts	260	312	366	418	465	
	430 CFM/ton	CFM	1305	1309	1309	1295	1242	
		Watts	319	373	428	482	502	
	450 CFM/ton	CFM	1370	1372	1371	1320	1242	
		Watts	360	415	473	502	502	

NOTE:
CONTINUOUS fan mode during **COOLING** operation may not be appropriate in humid climates. If the indoor air exceeds **60% relative humidity** or simply feels **uncomfortably humid**, it is recommended that the fan only be used in the **AUTO** mode.

*DH3 AIRFLOW - COOLING

*DH3C100ACV4VA Furnace Cooling Airflow (CFM) and Power (Watts) vs. External Static Pressure With Filter								
Unit Outdoor	Airflow Setting	External Static Pressure						
		0.1	0.3	0.5	0.7	0.9		
2.5	290 CFM/ton	CFM	723	713	699	682	661	
		Watts	58	109	157	204	234	
	310 CFM/ton	CFM	773	763	747	729	707	
		Watts	72	125	174	222	256	
	330 CFM/ton	CFM	823	812	795	776	753	
		Watts	87	141	192	241	279	
	350 CFM/ton	CFM	873	861	843	823	798	
		Watts	103	158	210	260	302	
	370 CFM/ton	CFM	923	910	892	870	844	
		Watts	120	177	229	279	325	
	400 CFM/ton	CFM	998	984	964	940	912	
		Watts	148	206	258	309	360	
	430 CFM/ton	CFM	1072	1058	1036	1011	981	
		Watts	179	238	290	341	396	
	450 CFM/ton	CFM	1122	1107	1084	1058	1026	
		Watts	201	260	312	362	420	
	3	290 CFM/ton	CFM	868	856	839	818	794
			Watts	101	157	208	258	299
310 CFM/ton		CFM	928	915	896	874	849	
		Watts	122	179	231	281	327	
330 CFM/ton		CFM	988	974	954	931	903	
		Watts	144	202	254	305	356	
350 CFM/ton		CFM	1047	1033	1012	987	958	
		Watts	169	227	279	330	384	
370 CFM/ton		CFM	1107	1092	1070	1044	1013	
		Watts	195	253	305	356	413	
400 CFM/ton		CFM	1197	1181	1157	1128	1095	
		Watts	237	296	346	395	455	
430 CFM/ton		CFM	1287	1269	1243	1213	1177	
		Watts	284	341	390	436	498	
450 CFM/ton		CFM	1347	1329	1301	1269	1232	
		Watts	317	373	420	465	526	
3.5		290 CFM/ton	CFM	1013	999	978	954	926
			Watts	154	212	265	315	367
	310 CFM/ton	CFM	1082	1068	1046	1020	990	
		Watts	184	242	294	345	401	
	330 CFM/ton	CFM	1152	1137	1113	1086	1054	
		Watts	215	274	325	375	434	
	350 CFM/ton	CFM	1222	1206	1181	1152	1118	
		Watts	250	308	358	406	467	
	370 CFM/ton	CFM	1292	1274	1248	1218	1182	
		Watts	286	344	392	439	500	
	400 CFM/ton	CFM	1397	1378	1349	1316	1277	
		Watts	346	401	446	489	548	
	430 CFM/ton	CFM	1501	1481	1451	1415	1373	
		Watts	411	463	503	541	595	
	450 CFM/ton	CFM	1571	1550	1518	1481	1437	
		Watts	457	507	543	577	625	
	4	290 CFM/ton	CFM	1157	1142	1118	1091	1058
			Watts	218	276	328	377	436
310 CFM/ton		CFM	1237	1220	1195	1166	1131	
		Watts	257	315	365	413	474	
330 CFM/ton		CFM	1317	1299	1272	1241	1204	
		Watts	300	357	405	450	512	
350 CFM/ton		CFM	1397	1378	1349	1316	1277	
		Watts	346	401	446	489	548	
370 CFM/ton		CFM	1476	1456	1426	1392	1350	
		Watts	395	448	489	529	584	
400 CFM/ton		CFM	1596	1575	1542	1504	1460	
		Watts	474	523	558	591	636	
430 CFM/ton		CFM	1716	1693	1658	1617	1569	
		Watts	560	604	631	726	726	
450 CFM/ton		CFM	1796	1771	1735	1693	1642	
		Watts	622	661	682	726	726	

Notes:

- * First letter may be "A" or "T".
- ** Factory setting.
- Continuous Fan Setting: Heating or cooling airflow is approximately 50% of selected cooling value.
- For variable speed low speed airflows are approximately 30% of listed values.
- LOW 350 cfm/ton is recommended for variable speed application for COMFORT & HUMID CLIMATE setting; NORMAL is 400 cfm/ton; HIGH 450 cfm/ton is for DRY CLIMATE setting.

NOTE:

CONTINUOUS fan mode during COOLING operation may not be appropriate in humid climates. If the indoor air exceeds 60% relative humidity or simply feels uncomfortably humid, it is recommended that the fan only be used in the AUTO mode.

Service Facts

*DH3 AIRFLOW - COOLING

*DH3D120ACV5VA Furnace Cooling Airflow (CFM) and Power (Watts) vs. External Static Pressure With Filter								
Unit Outdoor	Airflow Setting		External Static Pressure					
			0.1	0.3	0.5	0.7	0.9	
3.5	290 CFM/ton	CFM	970	1005	1029	1035	970	
		Watts	124	178	233	287	341	
	310 CFM/ton	CFM	1046	1076	1096	1099	1046	
		Watts	144	203	263	320	377	
	330 CFM/ton	CFM	1122	1148	1163	1163	1122	
		Watts	168	231	295	356	415	
	350 CFM/ton	CFM	1198	1219	1231	1228	1198	
		Watts	195	261	329	394	454	
	370 CFM/ton	CFM	1274	1290	1298	1292	1274	
		Watts	225	294	366	433	495	
	400 CFM/ton	CFM	1388	1397	1400	1389	1388	
		Watts	276	349	426	496	558	
	430 CFM/ton	CFM	1502	1504	1501	1486	1502	
		Watts	336	412	491	562	623	
	450 CFM/ton	CFM	1578	1576	1568	1550	1578	
		Watts	381	458	537	608	668	
	4	290 CFM/ton	CFM	1127	1153	1168	1168	1127
			Watts	170	233	297	359	417
310 CFM/ton		CFM	1214	1234	1245	1242	1214	
		Watts	201	268	337	402	463	
330 CFM/ton		CFM	1301	1316	1323	1315	1301	
		Watts	236	306	380	448	509	
350 CFM/ton		CFM	1388	1397	1400	1389	1388	
		Watts	276	349	426	496	558	
370 CFM/ton		CFM	1475	1479	1477	1463	1475	
		Watts	321	396	475	546	607	
400 CFM/ton		CFM	1605	1601	1592	1573	1605	
		Watts	399	475	555	625	684	
430 CFM/ton		CFM	1735	1723	1708	1683	1735	
		Watts	489	564	642	708	762	
450 CFM/ton		CFM	1822	1805	1785	1757	1822	
		Watts	557	630	704	766	814	
5		290 CFM/ton	CFM	1442	1448	1448	1435	1442
			Watts	304	378	456	527	589
	310 CFM/ton	CFM	1550	1550	1544	1527	1550	
		Watts	365	441	521	591	652	
	330 CFM/ton	CFM	1659	1652	1641	1619	1659	
		Watts	435	511	590	659	716	
	350 CFM/ton	CFM	1767	1754	1737	1711	1767	
		Watts	513	588	665	730	781	
	370 CFM/ton	CFM	1876	1856	1833	1803	1876	
		Watts	602	674	744	803	847	
	400 CFM/ton	CFM	2038	2009	1978	1941	1946	
		Watts	755	817	873	918	1031	
	430 CFM/ton	CFM	2201	2161	2100	2027	1946	
		Watts	933	981	1034	1034	1031	
	450 CFM/ton	CFM	2310	2180	2100	2027	1946	
		Watts	1067	1036	1034	1034	1031	

NOTE:
CONTINUOUS fan mode during **COOLING** operation may not be appropriate in humid climates. If the indoor air exceeds 60% relative humidity or simply feels uncomfortably humid, it is recommended that the fan only be used in the **AUTO mode**.

Notes:

- * First letter may be "A" or "T".
- ** Factory setting.
- Continuous Fan Setting: Heating or cooling airflow is approximately 50% of selected cooling value.
- For variable speed low speed airflows are approximately 30% of listed values.
- LOW 350 cfm/ton is recommended for variable speed application for COMFORT & HUMID CLIMATE setting; NORMAL is 400 cfm/ton; HIGH 450 cfm/ton is for DRY CLIMATE setting.

Service Facts

Alert Codes sorted by furnace Flash Codes

Alert codes are taken from the Alert Code Addendum and are organized by the furnace flash codes for easier reference.

Alert Notification				Alert Code	Alert Group	Alert Description
Fault LED	COM LED	User Interface Display	Control Display			
2 Flash	Device count	RECYCLE	N/A	20	Flame lost or Ignition failure	Flame is off when flame should be detected. Furnace tries to relight itself.
		RETRY				Furnace tries to light, but no flame is detected.
		RECYCLE LO	ERR 22	22	Soft lockout due to flame lost or ignition retries	10 recycles within a single call for heat will cause 1hr lockout.
		RETRY LO				3 ignition attempts in a row within a single call for heat results in 1 hr lockout.
3 Flash	Device count	PS3 OPEN	N/A	1	Pressure Switch Failure	Open Pressure Switch, third stage
		PS3 CLOSED				Shorted Pressure Switch, third stage
		PS2 OPEN				Open Pressure Switch, second stage
		PS2 CLOSED				Shorted Pressure Switch, second stage
		PS1 OPEN				Open Pressure Switch, first stage
		PS1 CLOSED				Shorted Pressure Switch, first stage
4 Flash	Device count	AUX LIMIT	ERR 26	26	High Temp Limit Fault	Open Reverse Flow - Heat exchanger temperature too high. Could be caused by low airflow or fan failure.
		HIGH LIMIT				Open High Limit - Heat exchanger temperature too high. Could be caused by low airflow or fan failure.
		ROLLOUT OPEN	ERR 87	87	Roll Out Fault	Open flame rollout
5 Flash	Device count	FLAME ERROR	ERR 34	34	Flame Detect Fault	Flame detected, should not be present
6 Flash	Device count	POLARITY ERR	N/A	33	Line Polarity Fault	Voltage reverse polarity
		GND FAULT	N/A	88	Ground Fault	Occurs when proper earth ground is not detected.
		IGNITER ERR	ERR 10	10	Ignition Means Fault	Igniter fault
		TRIAC ERR				Triac fault
7 Flash	Device count	EXT GV ERR	ERR 93	93	Gas Valve Fault	Control senses 24V present at the gas valve when it should not be present.
Solid ON		INT GV ERR				Control tried to turn on gas valve, but 24V not sensed.
8 Flash	Device count	LO FLAME SNS	N/A	4	Low Flame Signal	Flame current is low, but still strong enough to allow operation.
9 Flash	Device count	IND LIMIT	ERR 26	26	High Temp Limit Fault	Flue gas temperature too high. Could be caused by low airflow or fan failure.
10 Flash	Fast Flash	SYS COMM CRC	N/A	90	Communication Busy Fault	Comm system unrecognized response
		IND COMM CRC				Inducer Motor unrecognized response
		BLW COMM CRC				Blower motor unrecognized response
		BLW COMM ERR	ERR 91	91	Communication Fault	Blower motor no Comm response ¹
		IND COMM ERR				Inducer motor no Comm response
		SYS COMM ERR				Loss of heat/cool demand
Solid ON	Device count	CNTRL FAULT	ERR 18	18	Control Failure	Loss of clock signal
None	Device count	TWIN ERROR	N/A	19	Twinning Fault	Internal control failure
None	Device count	PM DATA ERR	N/A	114	Bad or Missing PM	Twinning Not Allowed with Variable Speed
		CAP MISMATCH				Data Section is Corrupt but PM is useable
		ID MTR ERR	ERR 114			Compressor size does not match capacity in PM
		PM MISSING				Blower HP/OEM does not match PM Data
		PM UNIT ERR	N/A			No PM
		PM MEM ERROR	ERR 114			Primary Copy of Unit Data File is Corrupt.
None	Device count	AC VOLTS LOW	N/A	59	AC Line Fault	Primary and Secondary copies of Unit Data File are Corrupt
		AC VOLTS HI				Voltage too low
None	Device count	CHECK FUSE	N/A	92	Fuse	Voltage too high
None	Device count	Y1 OFF ERR	ERR 101	101	Y1 Relay Failure	24V Fuse Open
		Y1 ON ERR				Y1 Output OFF when it should be ON
None	Device count	TS 1 SHORT	N/A	119	Temperature Sensor Failure	Y1 Output ON when it should be OFF
		TS 1 OPEN				Temperature sensor 1 shorted.
		TS 2 SHORT				Temperature sensor 1 open.
		TS 2 OPEN				Temperature sensor 2 shorted.
Notes:		¹ Comfort Control will switch system to "OFF" until this fault condition clears				

Service Facts

ALERT CODE RECOVERY

On power up, last 4 Alerts, if any, will be flashed on the Red Alert LED. The newest Alert detected will flash first and the oldest last. There will be a 2 second delay between Alert Code flashes. Solid Red LED error codes will not be displayed.

The Green BM LED will be on solid when the control is powered. The Green status LED indicator light will operate as shown in the table and the Red LED will flash (one flash) every 20 seconds.

NOTE:

Use the flash code menu for detail of the alerts. Alert codes also are displayed on the User Interface menu using a descriptive text message and on the comfort control display using an alert code number. A complete list of the alert codes is included with the comfort control.

LED	DESCRIPTION	FUNCTION
GREEN	STATUS LED	FAST FLASH - CALL FOR HEAT SLOW FLASH - NO CALL FOR HEAT
RED	ALERT LED	NO. OF FLASHES - SEE DIAGNOSTIC CODES
GREEN (BM)	BITMASTER	ON SOLID WHEN UNIT POWERED
AMBER	COM	FLASHES DEVICE COUNT

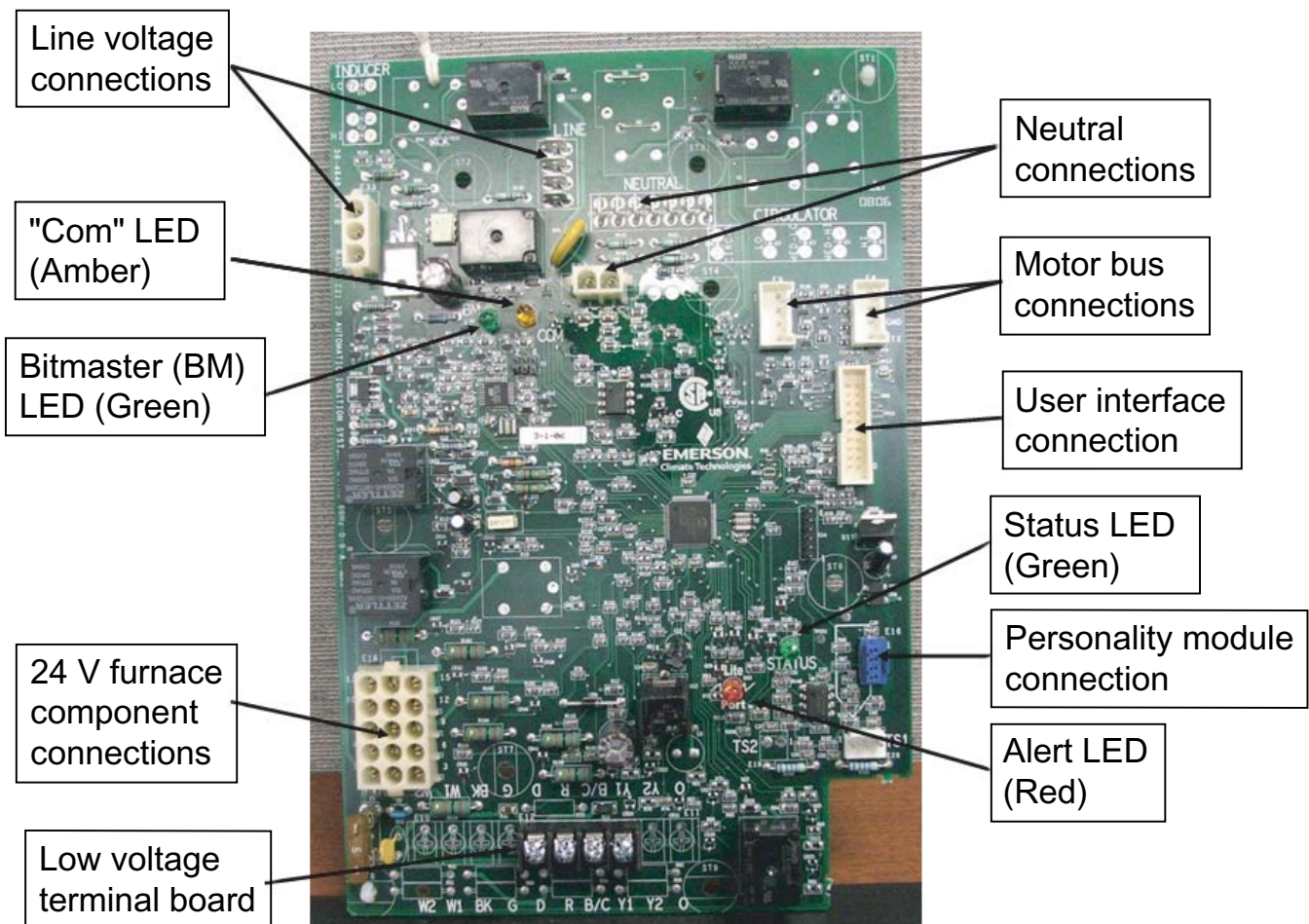



American Standard, Inc.
6200 Troup Highway
Tyler, TX 75707
www.americanstandard.com

For more information contact
your local dealer (distributor)

Since the manufacturer has a policy of continuous product and product data improvement, it reserves the right to change design and specifications without notice.

P.I. 09/07